

# 刀柄配件

HOLDER ACCESSORIES



## 刀柄配件系列

HOLDER ACCESSORIES

# 刀柄配件系列 HOLDER ACCESSORIES

## 直柄热缩延长杆 (4.5°标准型)

STRAIGHT HEAT SHRINKABLE EXTENSION ROD (4.5 STANDARD VERSION)



FIG. 1

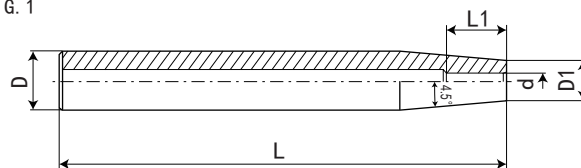
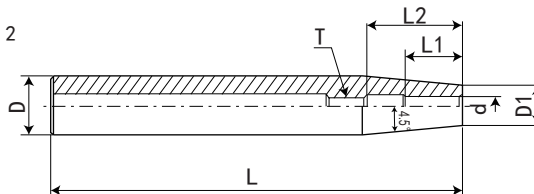

FIG. 2



规格 Model	L	L1	L2	D	D1	d	T	FIG	重量 KG
C12-SF03-120	120	12	*	12	8	3	*	1	0.09
C12-SF03-160	160	12	*	12	8	3	*	1	0.13
C12-SF03-200	200	12	*	12	8	3	*	1	0.17
C12-SF04-120	120	16	*	12	8	4	*	1	0.09
C12-SF04-160	160	16	*	12	8	4	*	1	0.13
C12-SF04-200	200	16	*	12	8	4	*	1	0.17
C12-SF05-120	120	18	*	12	10	5	*	1	0.09
C12-SF05-160	160	18	*	12	10	5	*	1	0.13
C12-SF06-120	120	26	36	12	10	6	M5*0.8P	2	0.17
C12-SF06-160	160	26	36	12	10	6	M5*0.8P	2	0.1
C12-SF08-120	120	26	36	12	12	8	M6*1.0P	2	0.14
C12-SF08-160	160	26	36	12	12	8	M6*1.0P	2	0.18

# 直柄热缩延长杆 (4.5°标准型)

STRAIGHT HEAT SHRINKABLE EXTENSION ROD (4.5 STANDARD VERSION)



FIG. 1

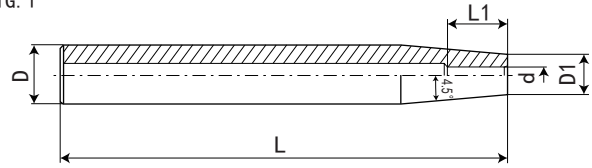
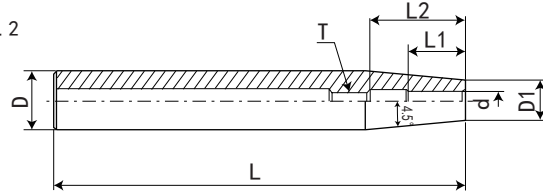

FIG. 2



规格 Model	L	L1	L2	D	D1	d	T	FIG	重量 KG
C16-SF03-120	120	12	*	16	10	3	*	1	0.18
C16-SF03-160	160	12	*	16	10	3	*	1	0.21
C16-SF03-200	200	12	*	16	10	3	*	1	0.24
C16-SF04-120	120	16	*	16	10	4	*	1	0.18
C16-SF04-160	160	16	*	16	10	4	*	1	0.21
C16-SF04-200	200	16	*	16	10	4	*	1	0.24
C16-SF05-120	120	18	*	16	10	5	*	1	0.18
C16-SF05-160	160	18	*	16	10	5	*	1	0.21
C16-SF05-200	200	18	*	16	10	5	*	1	0.24
C16-SF06-120	120	26	36	16	10	6	M5*0.8P	2	0.18
C16-SF06-160	160	26	36	16	10	6	M5*0.8P	2	0.21
C16-SF06-200	200	26	36	16	10	6	M5*0.8P	2	0.24
C16-SF08-120	120	26	36	16	12	8	M6*1.0P	2	0.18
C16-SF08-160	160	26	36	16	12	8	M6*1.0P	2	0.21
C16-SF08-200	200	26	36	16	12	8	M6*1.0P	2	0.24
C16-SF10-120	120	32	42	16	14	10	M8*1.0P	2	0.18
C16-SF10-160	160	32	42	16	14	10	M8*1.0P	2	0.21
C16-SF10-200	200	32	42	16	14	10	M8*1.0P	2	0.24

HOLDER  
ACCESSORIES  
刀柄配件

# 刀柄配件系列 HOLDER ACCESSORIES

## 直柄热缩延长杆 (4.5°标准型)

STRAIGHT HEAT SHRINKABLE EXTENSION ROD (4.5 STANDARD VERSION)



FIG. 1

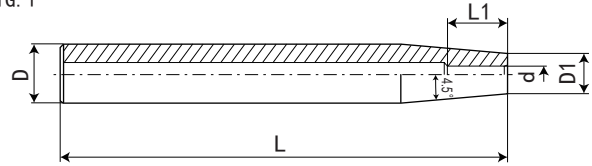
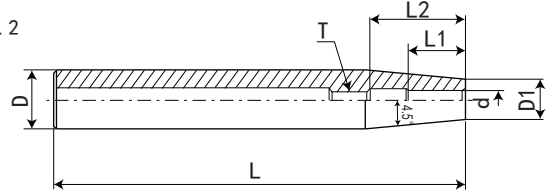

FIG. 2



规格 Model	L	L1	L2	D	D1	d	T	FIG	重量 KG
C20-SF03-120	120	12	*	20	10	3	*	1	
C20-SF03-160	160	12	*	20	10	3	*	1	0.35
C20-SF03-200	200	12	*	20	10	3	*	1	
C20-SF04-120	120	16	*	20	10	4	*	1	
C20-SF04-160	160	16	*	20	10	4	*	1	0.32
C20-SF04-200	200	16	*	20	10	4	*	1	
C20-SF05-120	120	18	*	20	14	5	*	1	
C20-SF05-160	160	18	*	20	14	5	*	1	0.3
C20-SF05-200	200	18	*	20	14	5	*	1	
C20-SF06-120	120	26	36	20	14	6	M5*0.8P	2	0.18
C20-SF06-160	160	26	36	20	14	6	M5*0.8P	2	0.31
C20-SF06-200	200	26	36	20	14	6	M5*0.8P	2	0.44
C20-SF06-250	250	26	36	20	14	6	M5*0.8P	2	0.57
C20-SF06-300	300	26	36	20	14	6	M5*0.8P	2	0.69
C20-SF08-120	120	26	36	20	14	8	M6*1.0P	2	0.15
C20-SF08-160	160	26	36	20	14	8	M6*1.0P	2	0.28
C20-SF08-200	200	26	36	20	14	8	M6*1.0P	2	0.41
C20-SF08-250	250	26	36	20	14	8	M6*1.0P	2	0.53
C20-SF08-300	300	26	36	20	14	8	M6*1.0P	2	0.66
C20-SF10-120	120	32	42	20	14	10	M8*1.0P	2	0.13
C20-SF10-160	160	32	42	20	14	10	M8*1.0P	2	0.26
C20-SF10-200	200	32	42	20	14	10	M8*1.0P	2	0.39
C20-SF10-250	250	32	42	20	14	10	M8*1.0P	2	0.51
C20-SF10-300	300	32	42	20	14	10	M8*1.0P	2	0.62
C20-SF12-120	120	37	47	20	16	12	M10*1.0P	2	0.11
C20-SF12-160	160	37	47	20	16	12	M10*1.0P	2	0.24
C20-SF12-200	200	37	47	20	16	12	M10*1.0P	2	0.37
C20-SF12-250	250	37	47	20	16	12	M10*1.0P	2	0.49
C20-SF12-300	300	37	47	20	16	12	M10*1.0P		0.6

# 直柄热缩延长杆 (4.5°标准型)

STRAIGHT HEAT SHRINKABLE EXTENSION ROD (4.5 STANDARD VERSION)

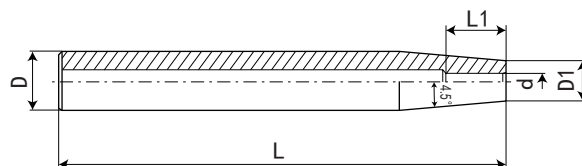

规格 Model	L	L1	L2	D	D1	d	T	重量 KG
C25-SF06-160	160	26	36	25	19	6	M5*0.8P	0.51
C25-SF06-200	200	26	36	25	19	6	M5*0.8P	0.68
C25-SF06-250	250	26	36	25	19	6	M5*0.8P	0.85
C25-SF06-300	300	26	36	25	19	6	M5*0.8P	1
C25-SF08-160	160	26	36	25	19	8	M6*1.0P	0.49
C25-SF08-200	200	26	36	25	19	8	M6*1.0P	0.66
C25-SF08-250	250	26	36	25	19	8	M6*1.0P	0.83
C25-SF08-300	300	26	36	25	19	8	M6*1.0P	0.98
C25-SF10-160	160	32	42	25	20	10	M8*1.0P	0.45
C25-SF10-200	200	32	42	25	20	10	M8*1.0P	0.62
C25-SF10-250	250	32	42	25	20	10	M8*1.0P	0.79
C25-SF10-300	300	32	42	25	20	10	M8*1.0P	0.94
C25-SF12-160	160	37	47	25	20	12	M10*1.0P	0.43
C25-SF12-200	200	37	47	25	20	12	M10*1.0P	0.6
C25-SF12-250	250	37	47	25	20	12	M10*1.0P	0.77
C25-SF12-300	300	37	47	25	20	12	M10*1.0P	0.92
C25-SF14-160	160	37	47	25	20	14	M10*1.0P	0.37
C25-SF14-200	200	37	47	25	20	14	M10*1.0P	0.55
C25-SF14-250	250	37	47	25	20	14	M10*1.0P	0.72
C25-SF14-300	300	37	47	25	20	14	M10*1.0P	0.87
C25-SF16-160	160	40	50	25	22	16	M12*1.0P	0.37
C25-SF16-200	200	40	50	25	22	16	M12*1.0P	0.55
C25-SF16-250	250	40	50	25	22	16	M12*1.0P	0.72
C25-SF16-300	300	40	50	25	22	16	M12*1.0P	0.87

HOLDER  
ACCESSORIES  
刀柄配件

# 刀柄配件系列 HOLDER ACCESSORIES

## 直柄热缩延长杆 (4.5°标准型)

STRAIGHT HEAT SHRINKABLE EXTENSION ROD (4.5 STANDARD VERSION)



FIG. 1

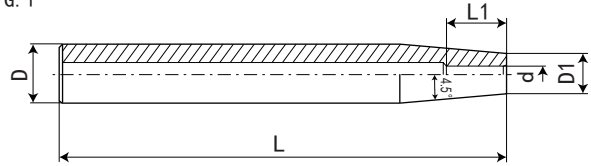
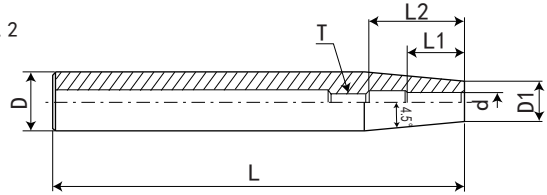

FIG. 2



规格 Model	L	L1	L2	D	D1	d	T	重量 KG
C32-SF10-160	160	32	42	32	24	10	M8*1.0P	0.9
-200	200	32	42	32	24	10	M8*1.0P	1.14
-250	250	32	42	32	24	10	M8*1.0P	1.38
-300	300	32	42	32	24	10	M8*1.0P	1.6
-SF12-160	160	37	47	32	24	12	M10*1.0P	0.76
-200	200	37	47	32	24	12	M10*1.0P	1
-250	250	37	47	32	24	12	M10*1.0P	1.25
-300	300	37	47	32	24	12	M10*1.0P	1.52
-SF14-160	160	37	47	32	27	14	M10*1.0P	0.7
-200	200	37	47	32	27	14	M10*1.0P	0.94
-250	250	37	47	32	27	14	M10*1.0P	1.18
-300	300	37	47	32	27	14	M10*1.0P	1.4
-SF16-160	160	40	50	32	27	16	M12*1.0P	0.67
-200	200	40	50	32	27	16	M12*1.0P	0.9
-250	250	40	50	32	27	16	M12*1.0P	1.13
-300	300	40	50	32	27	16	M12*1.0P	1.34
-SF18-160	160	40	50	32	27	18	M12*1.0P	0.61
-200	200	40	50	32	27	18	M12*1.0P	0.77
-250	250	40	50	32	27	18	M12*1.0P	0.93
-300	300	40	50	32	27	18	M12*1.0P	1.1
-SF20-160	160	42	52	32	27	20	M16*1.0P	0.52
-200	200	42	52	32	27	20	M16*1.0P	0.72
-250	250	42	52	32	27	20	M16*1.0P	0.92
-300	300	42	52	32	27	20	M16*1.0P	1.1



## 特点:

注:

- ◎材质: SUJ2 (高碳轴承钢: 在热处理后, 具有坚硬的硬度与韧性, 更好的耐磨耗性, 且弹性佳使用寿命更长)。
- ◎硬度: HRC44-48
- ◎表面粗糙度 RZ2.5 以内
- ◎ER8 的夹持范围为 0.5mm; ER11、16、20、25、32、40 的夹持范围为 1mm, 但孔径 2.5mm 以下, 夹持范围为 0.5mm; ER50 的夹持收缩范围 10mm 以下的收缩范围为 1mm, 10mm 以上的收缩范围为 2mm。
- ◎同心度按 DIN 标准规范全数检验。
- ◎用于夹持钻头、螺丝攻、铣刀、铰刀等工具。
- ◎具有弹性伸缩的功能、应用范围广、富变化性。

## Features:

- ◎ Material:SUJ2(High-carbon bearing steel:After heat treatment,it has hardness and toughness,better grinding quality,good flexibility,and longer using life span).
- ◎ HRC:HRC44-48
- ◎ Surface roughness:within RZ2.5.
- ◎ Chucking range:ER8=0.5mm;ER11/16/20/25/32/40=1mm. But if the internal hole is less than 2.5mm,the chucking range will be 0.5mm;ER50 clamping contraction range of 10mm or less shrinkage range is 1 mm,the shrinkage of more than 10 mm range of 2mm.
- ◎ The concentricity is totally examined according to DIN norm.
- ◎ It us used for the cutting tools loke drills,taps,mills,and remers,etc.
- ◎ It has flexibility and can be applied widely and variably.
- ◎ Please inform the required precision when ordering.

## 精湛的加工工艺 SUPER MACHING TECHNOLOGY

### 深冷处理:

注:

- ◎ -185°C 超长深冷处理, 使接近全部的残余奥氏体转变为马氏体
- ◎ 析出的纳米级碳化物颗粒, 增加硬度和韧性
- ◎ 减少残余应力
- ◎ 耐磨性显著提高
- ◎ ≥ 100h 超长定型热时效去除磨加工时的残余内应力

### Features:

- ◎ -185°C long cryogenic,nearly of the residual austenite into martensite.
- ◎ Carbide precipitation of Nanoscale particles,increasing the hardness and toughness
- ◎ Reducing residual stresses
- ◎ Wear resistance significantly improved
- ◎ Thermal aging processing  
≥ 100h long stereotyped thermal limitation removal of grinding residual stress.

# 刀柄配件系列 HOLDER ACCESSORIES

## 高精度 ER 弹性筒夹

## HIGH-PRECISION ER COLLET

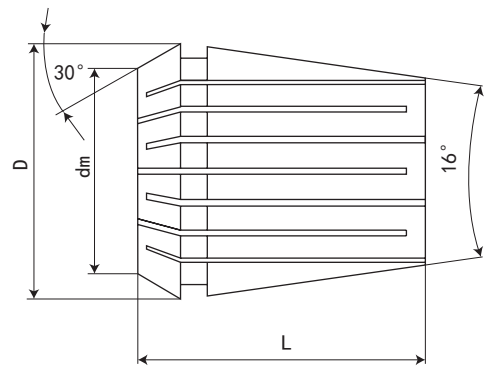
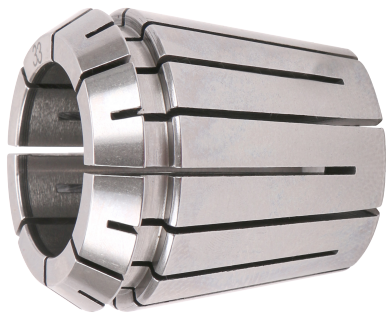

卡簧	ER8	ER11	ER16	ER20	ER25	ER32	ER40	ER50
dm 夹持范围	L/D	L/D	L/D	L/D	L/D	L/D	L/D	L/D
1.0-0.5	ER8-1.0	ER11-1.0	ER16-1.0	ER20-1.0	ER25-1.0	ER32-1.0	ER40-1.0	
1.5-1.0	ER8-1.5	ER11-1.5	ER16-1.5	ER20-1.5	ER25-1.5	ER32-1.5	ER40-1.5	
2.0-1.5	ER8-2.0	ER11-2.0	ER16-2.0	ER20-2.0	ER25-2.0	ER32-2.0	ER40-2.0	
2.5-2.0	ER8-2.5	ER11-2.5	ER16-2.5	ER20-2.5	ER25-2.5	ER32-2.5	ER40-2.5	
3.0-2.5	ER8-3.0	ER11-3.0	ER16-3.0	ER20-3.0	ER25-3.0	ER32-3.0	ER40-3.0	
3.5-3.0	ER8-3.5	ER11-3.5	ER16-3.5	ER20-3.5	ER25-3.5	ER32-3.5	ER40-3.5	
4.0-3.5	ER8-4.0	ER11-4.0	ER16-4.0	ER20-4.0	ER25-4.0	ER32-4.0	ER40-4.0	
4.5-4.0	ER8-4.5	ER11-4.5	ER16-4.5	ER20-4.5	ER25-4.5	ER32-4.5	ER40-4.5	
5.0-4.5	ER8-5.0	ER11-5.0	ER16-5.0	ER20-5.0	ER25-5.0	ER32-5.0	ER40-5.0	ER50-5.0
5.5-5.0		ER11-5.5	ER16-5.5	ER20-5.5	ER25-5.5	ER32-5.5	ER40-5.5	
6.0-5.5		ER11-6.0	ER16-6.0	ER20-6.0	ER25-6.0	ER32-6.0	ER40-6.0	ER50-6.0
6.5-6.0		ER11-6.5	ER16-6.5	ER20-6.5	ER25-6.5	ER32-6.5	ER40-6.5	
7.0-6.5		ER11-7.0	ER16-7.0	ER20-7.0	ER25-7.0	ER32-7.0	ER40-7.0	ER50-7.0
7.5-7.0			ER16-7.5	ER20-7.5	ER25-7.5	ER32-7.5	ER40-7.5	
8.0-7.5			ER16-8.0	ER20-8.0	ER25-8.0	ER32-8.0	ER40-8.0	ER50-8.0
8.5-8.0			ER16-8.5	ER20-8.5	ER25-8.5	ER32-8.5	ER40-8.5	
9.0-8.5			ER16-9.0	ER20-9.0	ER25-9.0	ER32-9.0	ER40-9.0	ER50-9.0
9.5-9.0			ER16-9.5	ER20-9.5	ER25-9.5	ER32-9.5	ER40-9.5	
10.0-9.5			ER16-10.0	ER20-10.0	ER25-10.0	ER32-10.0	ER40-10.0	ER50-10.0
10.5-10.0				ER20-10.5	ER25-10.5	ER32-10.5	ER40-10.5	
11.0-10.5				ER20-11.0	ER25-11.0	ER32-11.0	ER40-11.0	ER50-11.0
11.5-11.0				ER20-11.5	ER25-11.5	ER32-11.5	ER40-11.5	
12.0-11.5				ER20-12.0	ER25-12.0	ER32-12.0	ER40-12.0	ER50-12.0
12.5-12.0				ER20-12.5	ER25-12.5	ER32-12.5	ER40-12.5	
13.0-12.5				ER20-13.0	ER25-13.0	ER32-13.0	ER40-13.0	ER50-13.0
14.0-13.0					ER25-14.0	ER32-14.0	ER40-14.0	ER50-14.0
15.0-14.0					ER25-15.0	ER32-15.0	ER40-15.0	ER50-15.0
16.0-15.0					ER25-16.0	ER32-16.0	ER40-16.0	ER50-16.0
17.0-16.0						ER32-17.0	ER40-17.0	ER50-17.0
18.0-17.0						ER32-18.0	ER40-18.0	ER50-18.0
19.0-18.0						ER32-19.0	ER40-19.0	ER50-19.0
20.0-19.0						ER32-20.0	ER40-20.0	ER50-20.0
21.0-20.0							ER40-21.0	ER50-21.0
22.0-21.0							ER40-22.0	ER50-22.0
23.0-22.0							ER40-23.0	ER50-23.0
24.0-23.0							ER40-24.0	ER50-24.0
25.0-24.0							ER40-25.0	ER50-25.0
26.0-25.0							ER40-26.0	ER50-26.0
27.0-26.0								ER50-27.0
28.0-27.0								ER50-28.0
29.0-28.0								ER50-29.0
30.0-29.0								ER50-30.0
31.0-30.0								ER50-31.0
32.0-31.0								ER50-32.0
33.0-32.0								ER50-33.0
34.0-33.0								ER50-34.0
35.0-34.0								ER50-35.0
36.0-35.0								ER50-36.0



# ER 弹性筒夹

## ER COLLET

### 精度检测 INSPECTION OF ACCURACY

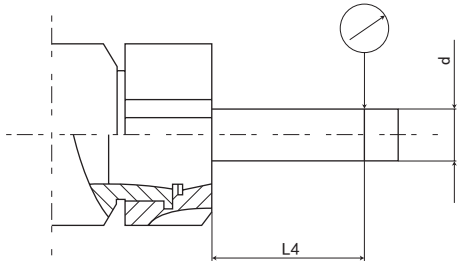

型号 Model No.	L4	d	径向跳动 Run out		
			A 级 A class	AA 级 AA class	AAA 级 AAA class
ER8	12	3	≤ 0.015	≤ 0.01	≤ 0.008
ER11	15	5	≤ 0.015	≤ 0.01	≤ 0.008
ER16	24	6	≤ 0.015	≤ 0.01	≤ 0.008
ER20	32	8	≤ 0.015	≤ 0.01	≤ 0.008
ER25	48	12	≤ 0.015	≤ 0.01	≤ 0.008
ER32	64	16	≤ 0.015	≤ 0.01	≤ 0.008
ER40	80	20	≤ 0.015	≤ 0.01	≤ 0.008
ER50	100	25	≤ 0.015	≤ 0.01	≤ 0.008



### A 级 经济型 ER 筒夹 0.015:

#### 特点:

- ◎ 材质: 65Mn
- ◎ 热处理硬度: HRC40-44
- ◎ 精度: ≤ 0.015

### A level Economical type ER collet

#### Feature:

- ◎ Material: 65Mn
- ◎ Hardness: HRC40-44
- ◎ Accuracy: ≤ 0.015



### AA 级 高精度 ER 筒夹 0.008:

#### 特点:

- ◎ 材质: 65Mn
- ◎ 热处理硬度: HRC44-48
- ◎ 精度: ≤ 0.008

### AA level Economical type ER collet

#### Feature:

- ◎ Material: 65Mn
- ◎ Hardness: HRC44-48
- ◎ Accuracy: ≤ 0.008



### AAA 级 高精度 ER 筒夹 0.008:

#### 特点:

- ◎ 材质: SUJ2
- ◎ 热处理硬度: HRC44-48
- ◎ 精度: ≤ 0.008
- ◎ -185°C 超长深冷处理, 使接近全部的残余奥氏体转变为马氏体

### AAA level Economical type ER collet

#### Feature:

- ◎ Material: SUJ2
- ◎ Hardness: HRC44-48
- ◎ Accuracy: ≤ 0.008
- ◎ -185 °C long cryogenic, nearly of the residual austenite into martensite.

# 刀柄配件系列 HOLDER ACCESSORIES

## ER 筒夹套装

## ER COLLET SET



刀柄配件  
HOLDER  
ACCESSORIES

### ER8 A级 A class

型号 Model No.	规格 Spec	支 / 套 PCS/SET
ER8-9PCS	1 1.5 2 2.5 3 3.5 4 4.5 5	9PCS/SET
ER8-6PCS(inch)	1/32 1/16 3/32 1/8 5/32 3/16	6PCS/SET

### ER11 A级 A class

型号 Model No.	规格 Spec	支 / 套 PCS/SET
ER11-7PCS	1 2 3 4 5 6 7	7PCS/SET
ER11-9PCS	3 3.5 4 4.5 5 5.5 6 6.5 7	9PCS/SET
ER11-13PCS	1 1.5 2 2.5 3 3.5 4 4.5 5 5.5 6 6.5 7	13PCS/SET
ER11-8PCS(inch)	1/32 1/16 3/32 1/8 5/32 3/16 7/32 1/4	8PCS/SET

### ER16 A级 A class

型号 Model No.	规格 Spec	支 / 套 PCS/SET
ER16-10PCS	1 2 3 4 5 6 7 8 9 10	10PCS/SET
ER16-8PCS	3 4 5 6 7 8 9 10	8PCS/SET
ER16-12PCS	1 1.5 2 2.5 3 4 5 6 7 8 9 10	12PCS/SET
ER16-12PCS(inch)	1/32 1/16 3/32 1/8 5/32 3/16 7/32 1/4 9/32 5/16 11/32 3/8	12PCS/SET
ER16-8PCS(inch)	1/8 5/32 3/16 7/32 1/4 5/16 11/32 3/8	8PCS/SET
ER16-5PCS(inch)	1/8 3/16 1/4 5/16 3/8	5PCS/SET

### ER20 AAA级 AAA class

型号 Model No.	规格 Spec	支 / 套 PCS/SET
ER20-12PCS	2 3 4 5 6 7 8 9 10 11 12 13	12PCS/SET
ER20-13PCS	1 2 3 4 5 6 7 8 9 10 11 12 13	13PCS/SET
ER20-11PCS	3 4 5 6 7 8 9 10 11 12 13	11PCS/SET
ER20-14PCS	1 1.5 2 3 4 5 6 7 8 9 10 11 12 13	14PCS/SET
ER20-16PCS(inch)	1/32 1/16 3/32 1/8 5/32 3/16 7/32 1/4 9/32 5/16 11/32 3/8 13/32 7/16 15/32 1/2	16PCS/SET
ER20-14PCS(inch)	3/32 1/8 5/32 3/16 7/32 1/4 9/32 5/16 11/32 3/8 13/32 7/16 15/32 1/2	14PCS/SET
ER20-11PCS(inch)	1/8 5/32 3/16 7/32 1/4 9/32 5/16 11/32 3/8 7/16 1/2	11PCS/SET

### ER25 AAA级 AAA class

型号 Model No.	规格 Spec	支 / 套 PCS/SET
ER25-14PCS	3 4 5 6 7 8 9 10 11 12 13 14 15 16	14PCS/SET
ER25-15PCS	2 3 4 5 6 7 8 9 10 11 12 13 14 15 16	15PCS/SET
ER25-18PCS	1 1.5 2 2.5 3 4 5 6 7 8 9 10 11 12 13 14 15 16	18PCS/SET
ER25-18PCS(inch)	3/32 1/8 5/32 3/16 7/32 1/4 9/32 5/16 11/32 3/8 13/32 7/16 15/32 1/2 17/32 9/16 19/32 5/8	18PCS/SET
ER25-9PCS(inch)	1/8 3/16 1/4 5/16 3/8 7/16 1/2 9/16 5/8	9PCS/SET

## ER 筒夹套装

## ER COLLET SET



ER32 A 级 A class

型号 Model No.	规格 Spec	支 / 套 PCS/SET
ER32-18PCS	3 4 5 6 7 8 9 10 11 12 13 14 15 16 17 18 19 20	18PCS/SET
ER32-19PCS	2 3 4 5 6 7 8 9 10 11 12 13 14 15 16 17 18 19 20	19PCS/SET
ER32-21PCS	1 1.5 2 3 4 5 6 7 8 9 10 11 12 13 14 15 16 17 18 19 20	21PCS/SET
ER32-18PCS(inch)	1/8 5/32 3/16 7/32 1/4 9/32 5/16 11/32 3/8 7/16 15/32 1/2 9/16 19/32 5/8 11/16 23/32 3/4	18PCS/SET
ER32-12PCS(inch)	1/8 5/32 3/16 1/4 5/16 3/8 7/16 1/2 9/16 5/8 11/16 3/4	12PCS/SET
ER32-11PCS(inch)	1/8 3/16 1/4 5/16 3/8 7/16 1/2 9/16 5/8 11/16 3/4	11PCS/SET
ER32-21PCS(inch)	1/8 5/32 3/16 7/32 1/4 9/32 5/16 11/32 3/8 13/32 7/16 15/32 1/2 17/32 9/16 19/32 5/8 21/32 11/16 23/32 3/4	21PCS/SET



ER40 A 级 A class

型号 Model No.	规格 Spec	支 / 套 PCS/SET
ER40-24PCS	3 4 5 6 7 8 9 10 11 12 13 14 15 16 17 18 19 20 21 22 23 24 25 26	24PCS/SET
ER40-23PCS	4 5 6 7 8 9 10 11 12 13 14 15 16 17 18 19 20 21 22 23 24 25 26	23PCS/SET
ER40-18PCS	4 5 6 7 8 9 10 11 12 13 14 15 16 17 18 19 20 25	18PCS/SET
ER40-15PCS	4 5 6 7 8 9 10 12 14 15 16 18 20 22 24 25 26	15PCS/SET
ER40-8PCS	4 6 8 10 12 16 20 25	8PCS/SET
ER40-23PCS(inch)	1/8 5/32 3/16 7/32 1/4 9/32 5/16 11/32 3/8 7/16 15/32 1/2 9/16 19/32 5/8 11/16 23/32 3/4 13/16 27/32 7/8 29/32 1"	23PCS/SET
ER40-18PCS(inch)	5/32 3/16 7/32 1/4 9/32 5/16 11/32 3/8 7/16 15/32 1/2 9/16 19/32 5/8 11/16 3/4 13/16 1"	18PCS/SET
ER40-15PCS(inch)	1/8 3/16 1/4 5/16 3/8 7/16 1/2 9/16 5/8 11/16 3/4 13/16 7/8 15/16 1"	15PCS/SET
ER40-14PCS(inch)	1/8 3/16 1/4 5/16 3/8 7/16 1/2 9/16 5/8 11/16 3/4 13/16 7/8 1"	14PCS/SET
ER40-8PCS(inch)	1/8 1/4 3/8 1/2 5/8 3/4 7/8 1"	8PCS/SET

HOLDER  
ACCESSORIES  
刀柄配件

## ER 筒夹木盘

## ER COLLET WOODEN TRAYS

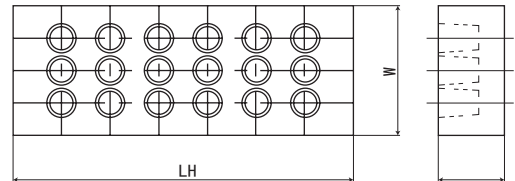

型号 Model No.	L (长)	W (宽)	H (高)	PCS	重量 KGS
ER8	210	20	13	9	0.01
ER11	210	20	13	13	0.01
ER16	275	35	22	10	0.14
ER20	275	35	22	12	0.12
ER25	275	77	26	16	0.18
ER32	340	90	30	18	0.48
ER40	265	210	38	24	0.76
ER50	235	210	37	12	0.64

# 刀柄配件系列 HOLDER ACCESSORIES

## ER 止水筒夹

## ER COOLANT COLLET

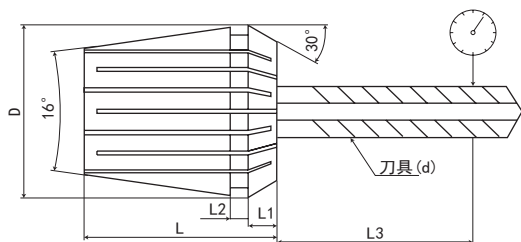

规格 / 型号 Model	d	夹持范围 Range	D	D1	L	L1
ER11S	3-7	0.1	11	11.5	18	3.8
ER16S	3-6	0.1	16	17	27.5	6.26
	6-10	0.5	16	17	27.5	6.26
ER20S	3-6	0.1	20	21	31.5	6.36
	6-13	0.5	20	21	31.5	6.36
ER25S	3-6	0.1	25	26	34	6.66
	6-16	0.5	25	26	34	6.66
ER32S	3-8	0.1	32	33	40	7.16
	8-20	0.5	32	33	40	7.16
ER40S	4-10	0.1	40	41	46	7.66
	10-26	0.5	40	41	46	7.66
ER50S	12-34	0.5	50	52	60	12.6

### 特点:

- ◎材料: SUJ2
- ◎硬度: HRC44-48
- ◎利用沟槽差异, 达到周围止水, 仅中心的功能
- ◎适用于夹持有出水孔的刀具
- ◎可承受水压 7Mpa
- ◎非标准孔可订制

### Features:

- ◎ Material:SUJ2
- ◎ Hardness:HRC44-48
- ◎ Differences in the use of grooves to reach around the sealing
- ◎ Central water feature only applies to folders to hold the water hole tool
- ◎ Can withstand water pressure 7Mpa
- ◎ Non-standard holes can be customized

### 精度检测 INSPECTION OF ACCURACY

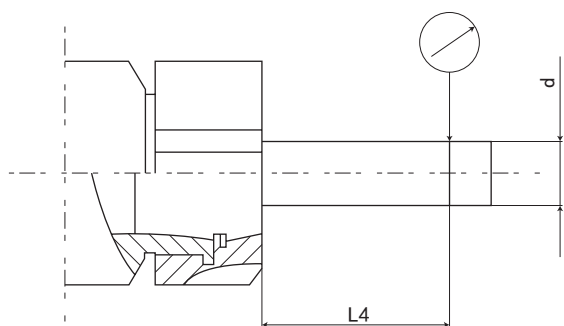

L4	d	径向跳动 Run out	
		A 级 A class	AA 级 AA class
16	3.0-6.0	≤ 0.008	≤ 0.005
25	6.0-10.0	≤ 0.008	≤ 0.005
40	10.0-18.0	≤ 0.008	≤ 0.005
50	18.0-27.0	≤ 0.008	≤ 0.005
60	27.0-34.0	≤ 0.015	≤ 0.01

### 特点:

- ◎利用沟槽的差异, 以及垫圈 (Sealed ring 封环) 的应用, 达到周围止水, 仅中心出水的功用。
- ◎适合于夹持出水孔的刀具
- ◎可承受水压达 21kgf/cm<sup>2</sup>
- ◎无弹性 (没有弹性夹持范围, 需看最大夹持范围)
- ◎非标准孔径如英制尺寸或是点数规格可接受订制
- ◎此产品 ER 部分依据 DIN6499, 可搭配合适的 (无) 刀杆

### Features:

- ◎ Take use of the difference of flute and the use of sealed ring to attain surrounding coolant and provide center as water outlet.
- ◎ Useful to chuck cutting tools with water outlet.
- ◎ Can bear the water pressure up to 21 kgf/cm<sup>2</sup>.
- ◎ No flexibility(NO flexible chucking range.It depends on the biggest chucking range).
- ◎ Non-standard type,such as inch type or decimal type,are welcomed to order.
- ◎ The ER part of the product is according to DIN-6499.It can be used with suitable tool holders.

# ER 止水筒夹

# ER COOLANT COLLET

HOLDER  
ACCESSORIES  
刀柄配件

ER11S		ER16S		ER20S		ER25S		ER32S		ER40S		ER50S	
规格 Type	夹持范围 Range	规格 Type	夹持范围 Range	规格 Type	夹持范围 Range	规格 Type	夹持范围 Range	规格 Type	夹持范围 Range	规格 Type	夹持范围 Range	规格 Type	夹持范围 Range
3S	3-2.9	3S	3-2.9	3S	3-2.9	3S	3-2.9	3S	3-2.9	4S	4-3.9	12S	12-11.5
4S	4-3.9	4S	4-3.9	4S	4-3.9	4S	4-3.9	4S	4-3.9	5S	5-4.9	14S	14-13.5
4.5S	4.5-4.4	4.5S	4.5-4.4	5S	5-4.9	5S	5-4.9	5S	5-4.9	6S	6-5.9	16S	16-15.5
5S	5-4.9	5S	5-4.9	5.5S	5.5-5.4	6S	6-5.5	6S	6-5.9	7S	7-6.9	16.5S	16.5-16
5.5S	5.5-5.4	5.5S	5.5-5.4	6S	6-5.5	6.5S	6.5-6	7S	7-6.9	8S	8-7.9	17S	17-16.5
6S	6-5.9	6S	6-5.5	6.5S	6.5-6	7S	7-6.5	8S	8-7.5	9S	9-8.9	17.5S	17.5-17
6.5S	6.5-6.4	6.5S	6.5-6	7S	7-6.5	7.5S	7.5-7	8.5S	8.5-8	10S	10-9.5	18S	18-17.5
7S	7-6.9	7S	7-6.5	7.5S	7.5-7	8S	8-7.5	9S	9-8.5	10.5S	10.5-10	18.5S	18.5-18
		7.5S	7.5-7	8S	8-7.5	8.5S	8.5-8	9.5S	9.5-9	11S	11-10.5	19S	19-18.5
		8S	8-7.5	8.5S	8.5-8	9S	9-8.5	10S	10-9.5	11.5S	11.5-11	19.5S	19.5-19
		8.5S	8.5-8	9S	9-8.5	9.5S	9.5-9	10.5S	10.5-10	12S	12-11.5	20S	20-19.5
		9S	9-8.5	9.5S	9.5-9	10S	10-9.5	11S	11-10.5	12.5S	12.5-12	20.5S	20.5-20
		9.5S	9.5-9	10S	10-9.5	10.5S	10.5-10	11.5S	11.5-11	13S	13-12.5	21S	21-20.5
		10S	10-9.5	10.5S	10.5-10	11S	11-10.5	12S	12-11.5	13.5S	13.5-13	21.5S	21.5-21
				11S	11-10.5	11.5S	11.5-11	12.5S	12.5-12	14S	14-13.5	22S	22-21.5
				11.5S	11.5-11	12S	12-11.5	13S	13-12.5	14.5S	14.5-14	22.5S	22.5-22
				12S	12-11.5	12.5S	12.5-12	13.5S	13.5-13	15S	15-14.5	23S	23-22.5
				12.5S	12.5-12	13S	13-12.5	14S	14-13.5	15.5S	15.5-15	23.5S	23.5-23
				13S	13-12.5	13.5S	13.5-13	14.5S	14.5-14	16S	16-15.5	24S	24-23.5
						14S	14-13.5	15S	15-14.5	16.5S	16.5-116	24.5S	24.5-24
						14.5S	14.5-14	15.5S	15.5-15	17S	17-16.5	25S	25-24.5
						15S	15-14.5	16S	16-15.5	17.5S	17.5-17	25.5S	25.5-25
						15.5S	15.5-15	16.5S	16.5-16	18S	18-17.5	26S	26-25.5
						16S	16-15.5	17S	17-16.5	18.5S	18.5-18	26.5S	26.5-26
								17.5S	17.5-17	19S	19-18.5	27S	27-26.5
								18S	18-17.5	19.5S	19.5-19	27.5S	27.5-27
								18.5S	18.5-18	20S	20-19.5	28S	28-27.5
								19S	19-18.5	20.5S	20.5-20	28.5S	28.5-28
								19.5S	19.5-19	21S	21-20.5	29S	29-28.5
								20S	20-19.5	21.5S	21.5-21	29.5S	29.5-29
										22S	22-21.5	30S	30-29.5
										22.5S	22.5-22	30.5S	30.5-30
										23S	23-22.5	31S	31-30.5
										23.5S	23.5-23	31.5S	31.5-31
										24S	24-23.5	32S	32-31.5
										24.5S	24.5-24	32.5S	32.5-32
										25S	25-24.5	33S	33-32.5
										25.5S	25.5-25	33.5S	33.5-33
										26S	26-25.5	34S	34-33.5

型号 Model No.	夹持能力 Capacity	规格 Type	支 / 套 PCS/SET
ER11S	3-7	3 4 4.5 5.5 6 6.5 7	8
ER16S	3-10	3 4 5 6 7 8 9 10	8
ER20S	3-13	3 4 5 6 7 8 9 10 11 12 13	11
ER25S	3-16	3 4 5 6 7 8 9 10 11 12 13 14 15 16	14
ER32S	3-20	3 4 5 6 7 8 9 10 11 12 13 14 15 16 17 18 19 20	18
ER40S	4-26	4 5 6 7 8 9 10 11 12 13 14 15 16 17 18 19 20 21 22 23 24 25 26	23
ER50S	12-34	12 14 16 18 20 22 24 26 28 30 32 34	12



### 特点:

注:

- ◎材质: SUJ2
- ◎硬度: HRC44-48
- ◎内孔多次研磨, 可达 Ra0.4, 起到镜面效果
- ◎筒夹锥前面的凸台设计, 工作中可防止粉尘、切屑的进入, 延长了使用寿命
- ◎外圆及端面多次研磨, 可达 Ra0.4, 起到镜面效果
- ◎表面 "环保" 特殊涂层处理, 提高表面硬度、耐磨性, 提高清洁度, 精度更稳定, 表面更光滑, 防锈、防腐蚀效果更好, 手感更舒适, 外型更美观
- ◎筒夹 4° 的半锥角设计, 更具有夹持力, 提高抗震性能

### Features:

- ◎ Material: SUJ2.
- ◎ HRC: HRC44-48.
- ◎ Inner hole grinding for many times, so as to reach Ra0.4, has a mirror effect.
- ◎ The design of the convex platform in front of the collet can prevent dust and chip getting into the collet when processing, prolong the tool's life.
- ◎ End and the cylindrical are grinding for many times, can reach Ra0.4, has a mirror effect.
- ◎ Surface "environmental protection", special coating surface treatment, improve the hardness and endurance of the surface, cleanliness better, accuracy stable, surface more smooth, antirust, feel comfortable, appearance nice.
- ◎ The design of 4° collet, more clamping force, to improve seismic performance.

## 精湛的加工工艺 SUPER MACHING TECHNOLOGY

### 深冷处理:

注:

- ◎ -185°C 超长深冷处理, 使接近全部的残余奥氏体转变为马氏体
- ◎ 析出的纳米级碳化物颗粒, 增加硬度和韧性
- ◎ 减少残余应力
- ◎ 耐磨性显著提高
- ◎ ≥ 100h 超长定型热时效去除磨加工时的残余内应力

### Features:

- ◎ -185°C long cryogenic, nearly of the residual austenite into martensite.
- ◎ Carbide precipitation of Nanoscale particles, increasing the hardness and toughness
- ◎ Reducing residual stresses
- ◎ Wear resistance significantly improved
- ◎ Thermal aging processing
- ◎ ≥ 100h long stereotyped thermal limitation removal of grinding residual stress.

# GSK 高速筒夹系列

# GSK HIGH SPEED COLLET SERIES

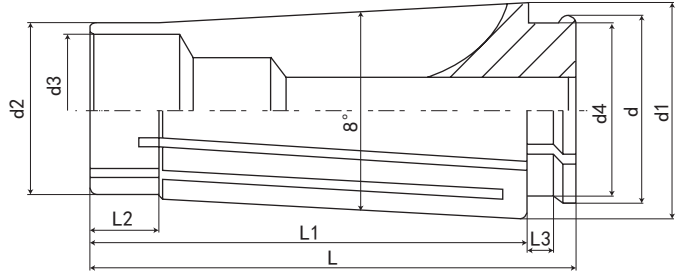

规格 / 型号 Model	d	d1	d2	d3	d4	L	L1	L2	L3
GSK06	8.9(8.6)	10.4(10.25)	7.5	6	7.6	25	17.4	3.8	2.2
GSK10	13.4(13)	15.45(15.3)	12	9.5	11.8	30.5	21.1	5.1	2.4
GSK13	17.05	19.97	15.5	12.5	15.1	39	27	6.5	2.4
GSK16	20.85	24.52	18.8	15.5	19	45	32.4	7.5	2.5
GSK20	24.95	29.1	22.6	19.5	23	54	40.7	8	2.9
GSK25	31	35.7	28.9	25	28.5	57	43.1	8.4	3

GSK06		GSK10		GSK13		GSK16		GSK20		GSK25	
型号 Model	范围 Range	型号 Model	范围 Range	型号 Model	范围 Range	型号 Model	范围 Range	型号 Model	范围 Range	型号 Model	范围 Range
GSK06-2	2-1.75	GSK10-2	2-1.75	GSK13-3	3-2.75	GSK16-3	3-2.75	GSK20-4	4-3.5	GSK25-6	6-6.5
GSK06-2.5	2.5-2.25	GSK10-2.5	2.5-2.25	GSK13-3.5	3.5-3	GSK16-3.175	3.175-2.7	GSK20-4.5	4.5-4	GSK25-8	8-7.5
GSK06-3	3-2.75	GSK10-3	3-2.75	GSK13-4	4-3.5	GSK16-3.5	3.5-3	GSK20-5	5-5.5	GSK25-10	10-9.5
GSK06-3.5	3.5-3	GSK10-3.175	3.175-2.7	GSK13-4.5	4.5-4	GSK16-4	4-3.5	GSK20-5.5	5.5-5	GSK25-12	12-11.5
GSK06-4	4-3.5	GSK10-3.5	3.5-3	GSK13-5	5-4.5	GSK16-4.5	4.5-4	GSK20-6	6-5.5	GSK25-14	14-13.5
GSK06-4.5	4.5-4	GSK10-4	4-3.5	GSK13-5.5	5.5-5	GSK16-5	5-4.5	GSK20-6.5	6.5-6	GSK25-16	16-15.5
GSK06-5	5-4.5	GSK10-4.5	4.5-4	GSK13-6	6-5.5	GSK16-5.5	5.5-5	GSK20-7	7-6.5	GSK25-16.5	16.5-16
GSK06-5.5	5.5-5	GSK10-5	5-4.5	GSK13-6.5	6.5-6	GSK16-6	6-5.5	GSK20-7.5	7.5-7	GSK25-17	17-16.5
GSK06-6	6-5.5	GSK10-5.5	5.5-5	GSK13-7	7-6.5	GSK16-6.5	6.5-6	GSK20-8	8-7.5	GSK25-17.5	17.5-17
		GSK10-6	6-5.5	GSK13-7.5	7.5-7	GSK16-7	7-6.5	GSK20-8.5	8.5-8	GSK25-18	18-17.5
		GSK10-6.5	6.5-6	GSK13-8	8-7.5	GSK16-7.5	7.5-7	GSK20-9	9-8.5	GSK25-18.5	18.5-18
		GSK10-7	7-6.5	GSK13-8.5	8.5-8	GSK16-8	8-7.5	GSK20-9.5	9.5-9	GSK25-19	19-18.5
		GSK10-7.5	7.5-7	GSK13-9	9-8.5	GSK16-8.5	8.5-8	GSK20-10	10-9.5	GSK25-19.5	19.5-19
		GSK10-8	8-7.5	GSK13-9.5	9.5-9	GSK16-9	9-8.5	GSK20-10.5	10.5-10	GSK25-20	20-19.5
		GSK10-8.5	8.5-8	GSK13-10	10-9.5	GSK16-9.5	9.5-9	GSK20-11	11-10.5	GSK25-20.5	20.5-20
		GSK10-9	9-8.5	GSK13-10.5	10.5-10	GSK16-10	10-9.5	GSK20-11.5	11.5-11	GSK25-21	21-20.5
		GSK10-9.5	9.5-9	GSK13-11	11-10.5	GSK16-10.5	10.5-10	GSK20-12	12-11.5	GSK25-21.5	21.5-21
		GSK10-10	10-9.5	GSK13-11.5	11.5-11	GSK16-11	11-10.5	GSK20-12.5	12.5-12	GSK25-22	22-21.5
				GSK13-12	12-11.5	GSK16-11.5	11.5-11	GSK20-13	13-12.5	GSK25-22.5	22.5-22
				GSK13-12.5	12.5-12	GSK16-12	12-11.5	GSK20-13.5	13.5-13	GSK25-23	23-22.5
				GSK13-13	13-12.5	GSK16-12.5	12.5-12	GSK20-14	14-13.5	GSK25-23.5	23.5-23
						GSK16-13	13-12.5	GSK20-14.5	14.5-14	GSK25-24	24-23.5
						GSK16-13.5	13.5-13	GSK20-15	15-14.5	GSK25-24.5	24.5-24
						GSK16-14	14-13.5	GSK20-15.5	15.5-15	GSK25-25	25-24.5
						GSK16-14.5	14.5-14	GSK20-16	16-15.5		
						GSK16-15	15-14.5	GSK20-16.5	16.5-16		
						GSK16-15.5	15.5-15	GSK20-17	17-16.5		
						GSK16-16	16-15.5	GSK20-17.5	17.5-17		
								GSK20-18	18-17.5		
								GSK20-18.5	18.5-18		
								GSK20-19	19-18.5		
								CSK20-19.5	19.5-19		
								CSK20-20	20-19.5		

HOLDER  
 ACCESSORIES  
 刀柄配件

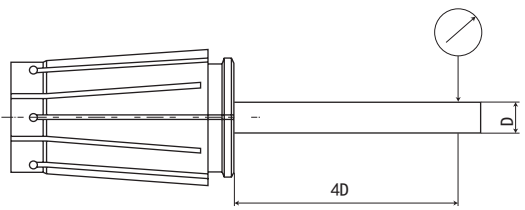

L	径向跳动 (Run out)	
	A 级 (A class)	AA 级 (AA class)
4XD	≤ 0.01	≤ 0.008

◎材质: SUJ2                      ◎ Material: SUJ2  
 ◎热处理硬度: HRC44-48      ◎ Hardness: HRC44-48

# 刀柄配件系列 HOLDER ACCESSORIES

## DIN6388A 标准 EOC 系列铣夹头

## DIN6388A EOC COLLETS

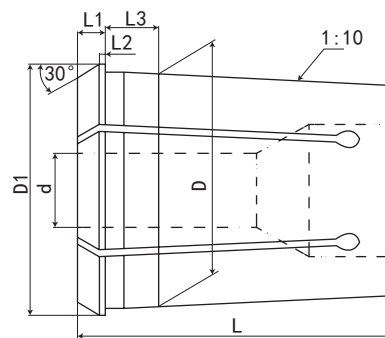
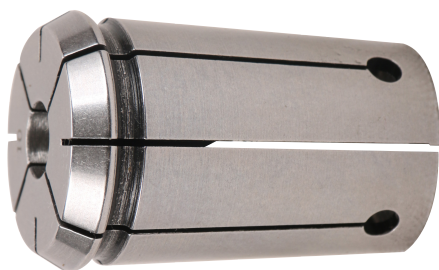

夹持工件或刀具柄允差: h11 Clamp workpiece or tooling shank tolerance h11

规格 / 型号 Model	D	D1	d	L	L1	L2	L3
EOC6A	10	11.5	1-6	21	3.5	0.5	4
EOC8A	12.65	14.5	1-8	26	4	0.8	4.5
EOC10A	15.15	17.2	1-10	30	4.5	0.8	4.5
EOC12A	17.75	19.8	1-12	34	5	1.1	4.5
EOC16A	22.65	25.5	2-16	40	5.5	1.2	5.5
EOC20A	27.4	29.8	2-20	45	6	1.35	6
EOC25A	32.9	35.05	2-25	52	6	1.4	6
EOC32A	41.3	43.7	4-32	60	6	1.45	7
EOC40A	49.7	52.2	6-40	68	6	1.45	8
EOC50A	61.1	63.8	8-50	80	7	1.55	9

## DIN6388B 标准 EOC 系列铣夹头

## DIN6388B EOC COLLETS

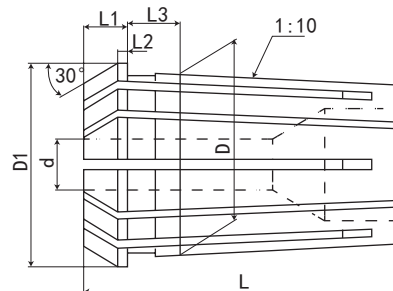
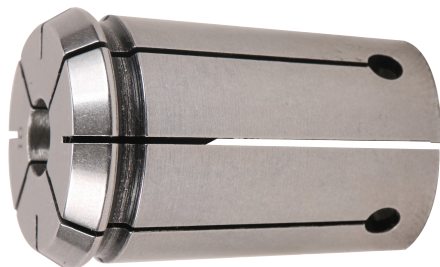

最大夹持范围: 0.5mm Max clamping range: 0.5mm

规格 / 型号 Model	D	D1	d	L	L1	L2	L3
EOC16B	22.65	25.5	2-16	40	5.5	1.2	9.5
EOC20B	27.4	29.8	2-20	45	6	1.35	10
EOC25B	32.9	35.05	2-25	52	6	1.4	10
EOC32B	41.3	43.7	4-32	60	6	1.45	11
EOC40B	49.7	52.2	6-40	68	6	1.45	12
EOC50B	61.1	63.8	8-50	80	7	1.55	13

### 精度检测 Inspection of accuracy

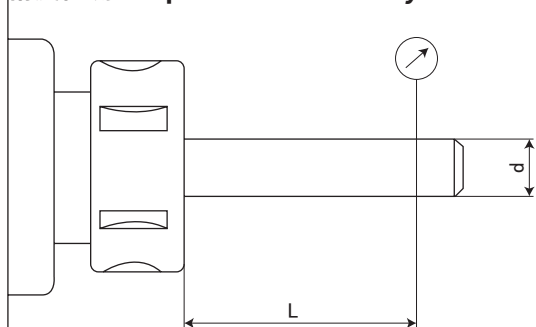

D	L	径向跳动 Run out	
		AA级 AA class	A级 A class
1.0-1.6	6	0.010	0.015
> 1.6-3.0	10	0.010	0.015
> 3.0-7.0	16	0.010	0.015
> 7.0-10.0	25	0.010	0.015
> 10.0-18.0	40	0.015	0.020
> 18.0-24.0	50	0.015	0.020
> 24.0-30.0	60	0.015	0.020
> 30.0-50.0	80	0.020	0.030

说明: 无特殊要求, 一般 A 级供货, 如需 AA 级, 则需特殊订货, 价格另议

If no special requirement, we would supply to you according to A grade, if you require AA grade, the price would be advanced



# C 型强力直柄筒夹

# C STRAIGHT COLLET

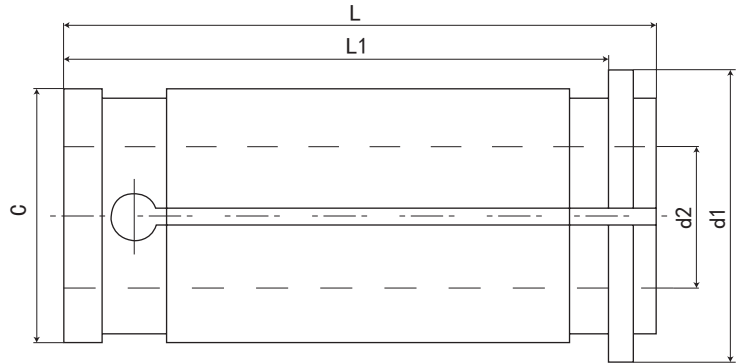
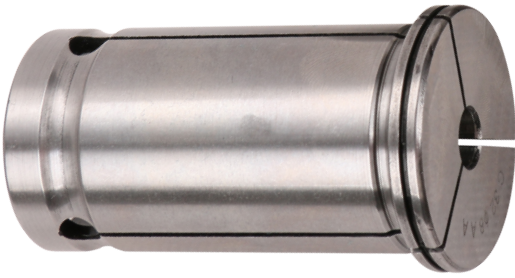

规格 / 型号 Model	夹持范围 d2 Range	C	d1	L	L1
SC16	3/4/5/6/7/8/9/10/11/12	16	25	49	47
SC20	3/4/5/6/7/8/9/10/11/12/13/14/15/16	20	25	52.5	49
SC22	3/4/5/6/7/8/9/10/11/12/13/14/15/16	22	26	55	51.5
SC25	3/4/5/6/7/8/9/10/11/12/13/14/15/16/18/19/20	25	30	60	55
SC32	3/4/5/6/7/8/9/10/11/12/13/14/15/16/18/19/20/21/22/23/24/25/26	32	37.5	65	60
SC42	3/4/5/6/7/8/9/10/11/12/13/14/15/16/18/19/20/21/22/23/24/25/26 27/28/29/30/31/32/33/34/35/36	42	47	75	69
英制规格可订购 Inch size can be ordered					

d	L	径向跳动 Run out(mm)	
		普通级 General level	高精度 High precision
< 10	30	0.015	0.01
≥ 10-20	50	0.015	0.01
> 20	80	0.02	0.01

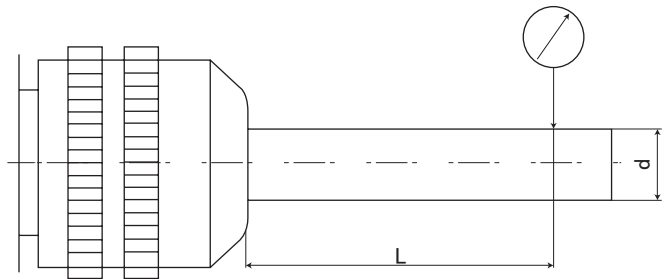

## 特点:

- ◎ 材质: SUJ-2
- ◎ 硬度: HRC44-48
- ◎ 偏摆精度: ≤ 0.01mm
- ◎ 限定夹持与孔径相同之刀具柄径
- ◎ 筒夹不具备弹性收缩范围, 强调夹持力
- ◎ 刀具置入筒夹必须超过内孔有效夹持长度, 以达到有效夹持
- ◎ 共有两种精度等级: 高精度 0.01 mm 及普通级 0.015mm
- ◎ 订购时请告知所需精度等级

## Features:

- ◎ Material: SUJ-2.
- ◎ Hardness: HRC44-48
- ◎ Precision: ≤ 0.01mm
- ◎ Definition clamp and aperture same shank of tool diameter.
- ◎ The collet does not have the elastic contraction scope, the emphasis chucking power.
- ◎ In the cutting tool posts the collet to surpass the hole effective clamp length, achieves the effective clamp.
- ◎ There are two kinds of classes for precision: High precision 0.01 mm, General level 0.015mm.
- ◎ Please inform the required precision when ordering.

# 刀柄配件系列 HOLDER ACCESSORIES

## 液压筒夹 (标准型)

## HYDRAULIC COLLET (STANDARD)

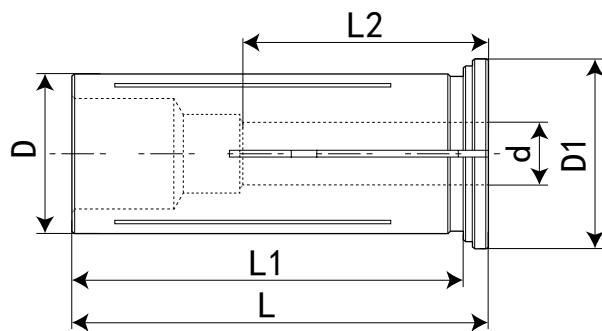

规格 Model	L	L1	L2	D1	D	d	重量 KG
HC12-03	48	45.9	16.9	19	12	3	
HC12-1/8	48	45.9	16.9	19	12	3.175	
HC12-04	48	45.9	21	19	12	4	
HC12-05	48	45.9	23	19	12	5	
HC12-06	48	45.9	27	19	12	6	
HC12-08	48	45.9	25.8	19	12	8	
HC12-10	48	45.9	48	19	12	10	

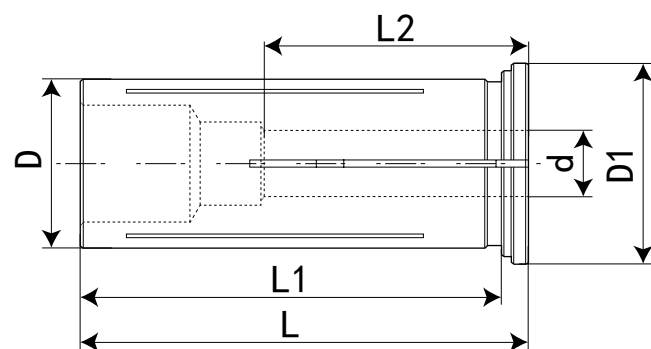

规格 Model	L	L1	L2	D1	D	d	重量 KG
HC20-03	54	51	21	23.9	20	3	
HC20-1/8	54	51	21	23.9	20	3.175	
HC20-04	54	51	21.5	23.9	20	4	
HC20-05	54	51	24	23.9	20	5	
HC20-06	54	51	28.5	23.9	20	6	
HC20-08	54	51	31.6	23.9	20	8	
HC20-10	54	51	39.4	23.9	20	10	
HC20-12	54	51	39.2	23.9	20	12	
HC20-14	54	51	54	23.9	20	14	
HC20-16	54	51	54	23.9	20	16	

# 液压筒夹 (标准型)

# HYDRAULIC COLLET (STANDARD)

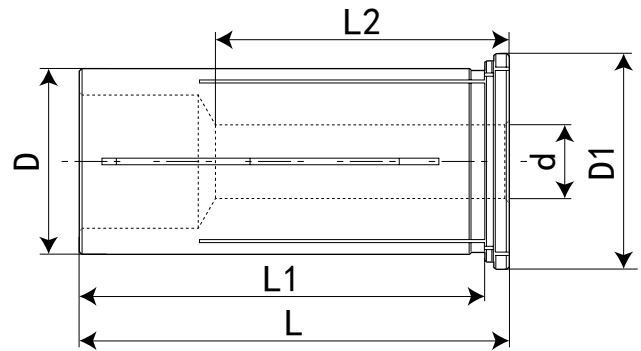

规格 Model	L	L1	L2	D1	D	d	重量 KG
HC25-03	58	54.8	25	29	25	3	
HC25-1/8	58	54.8	25	29	25	3.175	
HC25-04	58	54.8	25.8	29	25	4	
HC25-05	58	54.8	25.8	29	25	5	
HC25-06	58	54.8	30.5	29	25	6	
HC25-08	58	54.8	33.6	29	25	8	
HC25-10	58	54.8	39.7	29	25	10	
HC25-12	58	54.8	40.3	29	25	12	
HC25-14	58	54.8	40.8	29	25	14	
HC25-16	58	54.8	40.4	29	25	16	
HC25-18	58	54.8	40.5	29	25	18	
HC25-20	58	54.8	58	29	25	20	

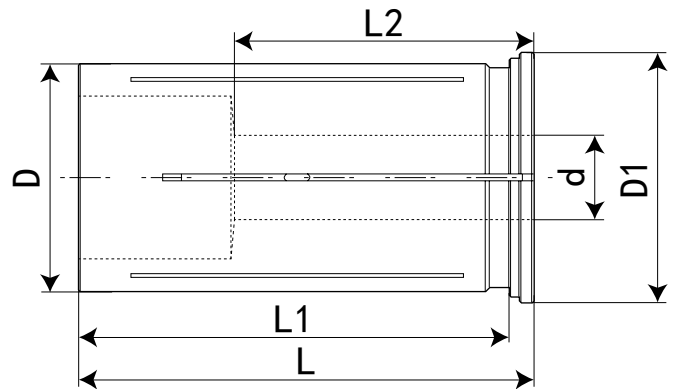

规格 Model	L	L1	L2	D1	D	d	重量 KG
HC32-05	64	60.6	25.5	35.2	32	5	
HC32-06	64	60.6	27.4	35.2	32	6	
HC32-08	64	60.6	31	35.2	32	8	
HC32-10	64	60.6	42.4	35.2	32	10	
HC32-12	64	60.6	42.4	35.2	32	12	
HC32-14	64	60.6	45	35.2	32	14	
HC32-16	64	60.6	51.3	35.2	32	16	
HC32-18	64	60.6	51.3	35.2	32	18	
HC32-20	64	60.6	52.4	35.2	32	20	
HC32-22	64	60.6	52.4	35.2	32	22	
HC32-24	64	60.6	53.6	35.2	32	24	
HC32-25	64	60.6	56.9	35.2	32	25	
HC32-26	64	60.6	57.5	35.2	32	26	

HOLDER  
ACCESSORIES  
刀柄配件

# 刀柄配件系列 HOLDER ACCESSORIES

## 液压筒夹 (止水型)

## HYDRAULIC COLLET (SEALED)

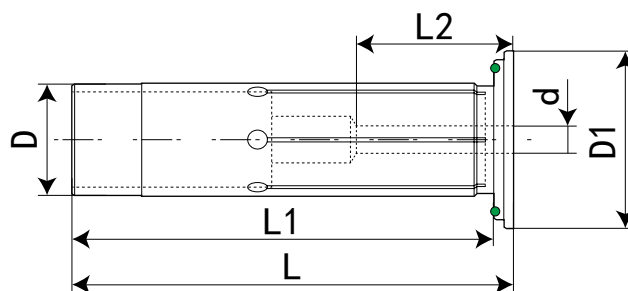

规格 Model	L	L1	L2	D1	D	d	重量 KG
HDC8-02	37.5	35.5	14.5	12.5	8	2	
HDC8-03	37.5	35.5	16.5	12.5	8	3	
HDC8-1/8	37.5	35.5	16.5	12.5	8	3.175	
HDC8-04	37.5	35.5	16.5	12.5	8	4	
HDC8-05	37.5	35.5	16.5	12.5	8	5	
HDC8-06	37.5	35.5	24	12.5	8	6	

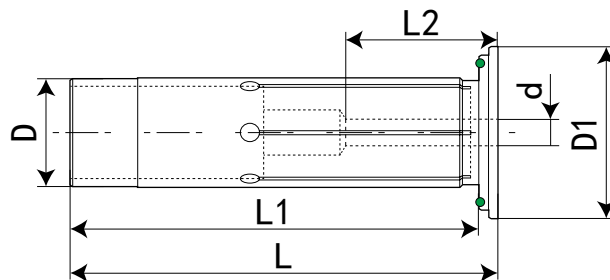

规格 Model	L	L1	L2	D1	D	d	重量 KG
HDC12-02	47.5	45.5	14.5	19	12	2	
HDC12-03	47.5	45.5	16.5	19	12	3	
HDC12-1/8	47.5	45.5	16.5	19	12	3.175	
HDC12-04	47.5	45.5	16.5	19	12	4	
HDC12-05	47.5	45.5	16.5	19	12	5	
HDC12-06	47.5	45.5	24	19	12	6	
HDC12-07	47.5	45.5	24	19	12	7	
HDC12-08	47.5	45.5	25.5	19	12	8	
HDC12-09	47.5	45.5	32.5	19	12	9	
HDC12-10	47.5	45.5	32.5	19	12	10	

# 液压筒夹 (止水型)

# HYDRAULIC COLLET (SEALED)

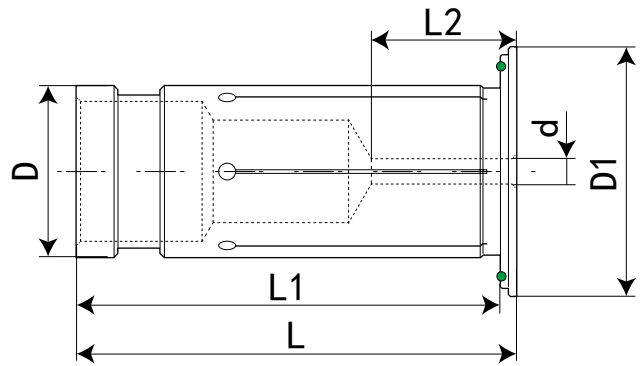

规格 Model	L	L1	L2	D1	D	d	重量 KG
HDC16-02	49.5	47.5	14.5	23	16	2	
HDC16-03	49.5	47.5	16.5	23	16	3	
HDC16-1/8	49.5	47.5	16.5	23	16	3.175	
HDC16-04	49.5	47.5	16.5	23	16	4	
HDC16-05	49.5	47.5	16.5	23	16	5	
HDC16-06	49.5	47.5	24	23	16	6	
HDC16-07	49.5	47.5	24	23	16	7	
HDC16-08	49.5	47.5	25.5	23	16	8	
HDC16-09	49.5	47.5	32.5	23	16	9	
HDC16-10	49.5	47.5	32.5	23	16	10	
HDC16-11	49.5	47.5	36	23	16	11	
HDC16-12	49.5	47.5	36	23	16	12	

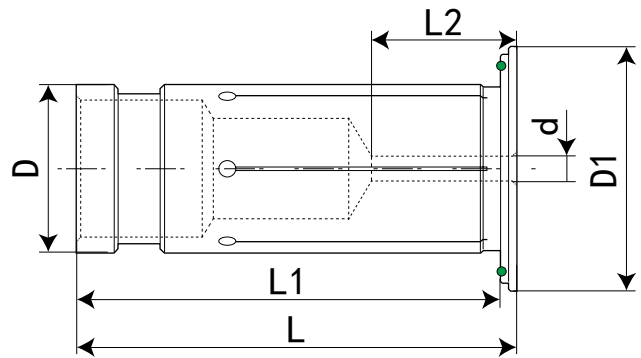

规格 Model	L	L1	L2	D1	D	d	重量 KG
HDC20-02	52.5	50.5	14.5	29	20	2	
HDC20-03	52.5	50.5	17.5	29	20	3	
HDC20-1/8	52.5	50.5	17.5	29	20	3.175	
HDC20-04	52.5	50.5	17.5	29	20	4	
HDC20-05	52.5	50.5	17.5	29	20	5	
HDC20-06	52.5	50.5	25.5	29	20	6	
HDC20-07	52.5	50.5	28	29	20	7	
HDC20-08	52.5	50.5	28	29	20	8	
HDC20-09	52.5	50.5	32.5	29	20	9	
HDC20-10	52.5	50.5	32.5	29	20	10	
HDC20-11	52.5	50.5	36	29	20	11	
HDC20-12	52.5	50.5	36	29	20	12	
HDC20-13	52.5	50.5	36.5	29	20	13	
HDC20-14	52.5	50.5	37	29	20	14	
HDC20-15	52.5	50.5	37	29	20	15	
HDC20-16	52.5	50.5	37.5	29	20	16	

HOLDER  
ACCESSORIES  
刀柄配件

# 刀柄配件系列 HOLDER ACCESSORIES

## 液压筒夹 (止水型)

## HYDRAULIC COLLET (SEALED)

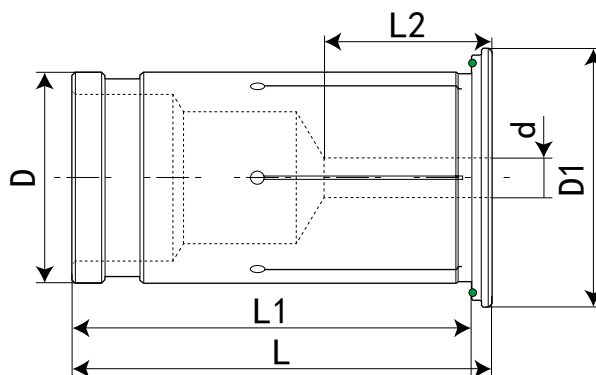

规格 Model	L	L1	L2	D1	D	d	重量 KG
HDC25-02	58.5	55.5	14.5	32	25	2	
HDC25-03	58.5	55.5	17.5	32	25	3	
HDC25-1/8	58.5	55.5	17.5	32	25	3.175	
HDC25-04	58.5	55.5	17.5	32	25	4	
HDC25-05	58.5	55.5	17.5	32	25	5	
HDC25-06	58.5	55.5	25.5	32	25	6	
HDC25-07	58.5	55.5	26.5	32	25	7	
HDC25-08	58.5	55.5	27.5	32	25	8	
HDC25-09	58.5	55.5	28.5	32	25	9	
HDC25-10	58.5	55.5	30.5	32	25	10	
HDC25-11	58.5	55.5	30.5	32	25	11	
HDC25-12	58.5	55.5	30.5	32	25	12	
HDC25-13	58.5	55.5	31.5	32	25	13	
HDC25-14	58.5	55.5	32.5	32	25	14	
HDC25-15	58.5	55.5	36.5	32	25	15	
HDC25-16	58.5	55.5	40.5	32	25	16	
HDC25-17	58.5	55.5	40.5	32	25	17	
HDC25-18	58.5	55.5	40.5	32	25	18	
HDC25-19	58.5	55.5	40.5	32	25	19	
HDC25-20	58.5	55.5	40.5	32	25	20	

# 液压筒夹 (止水型)

# HYDRAULIC COLLET (SEALED)

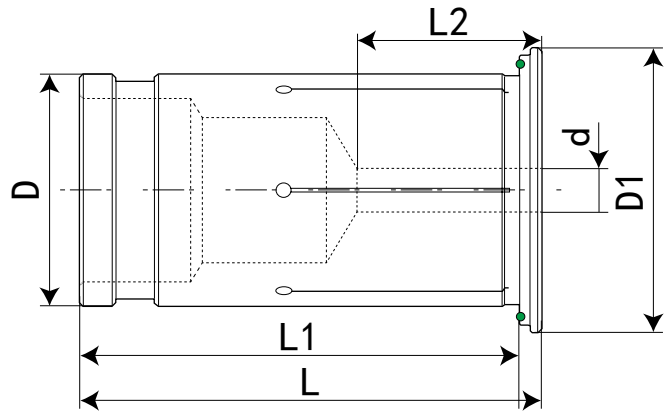

规格 Model	L	L1	L2	D1	D	d	重量 KG
HDC32-04	63.5	60.5	17.5	39	32	4	
HDC32-05	63.5	60.5	17.5	39	32	5	
HDC32-06	63.5	60.5	25.5	39	32	6	
HDC32-07	63.5	60.5	26.5	39	32	7	
HDC32-08	63.5	60.5	27.5	39	32	8	
HDC32-09	63.5	60.5	28.5	39	32	9	
HDC32-10	63.5	60.5	30.5	39	32	10	
HDC32-11	63.5	60.5	30.5	39	32	11	
HDC32-12	63.5	60.5	30.5	39	32	12	
HDC32-13	63.5	60.5	31.5	39	32	13	
HDC32-14	63.5	60.5	32.5	39	32	14	
HDC32-15	63.5	60.5	36.5	39	32	15	
HDC32-16	63.5	60.5	40.5	39	32	16	
HDC32-17	63.5	60.5	40.5	39	32	17	
HDC32-18	63.5	60.5	40.5	39	32	18	
HDC32-19	63.5	60.5	40.5	39	32	19	
HDC32-20	63.5	60.5	40.5	39	32	20	
HDC32-22	63.5	60.5	44.5	39	32	22	
HDC32-24	63.5	60.5	44.5	39	32	24	
HDC32-25	63.5	60.5	48.5	39	32	25	
HDC32-26	63.5	60.5	48.5	39	32	26	

# 刀柄配件系列 HOLDER ACCESSORIES

## 日本标准拉钉 MAS 403-1975

## JAPANESE STANDARD PULL STUD MAS 403-1975

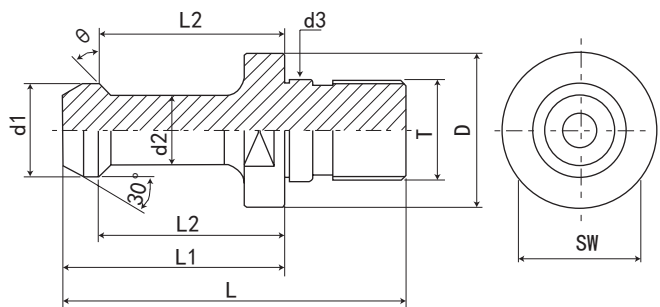

标准型 Standard type

规格 / 型号 Model	D	d1	d2	d3	L	L1	L2	T	重量 KGS
BT30-45°	16.5	11	7	12.5	43	23	18	M12	0.04
BT40-45°	23	15	10	17	60	35	28	M16	0.1
BT50-45°	38	23	17	25	85	45	35	M24	0.3
BT60-45°	56	32	24	31	115	65	53	M30	0.4
BT30-60°	16.5	11	7	12.5	43	23	18	M12	0.04
BT40-60°	23	15	10	17	60	35	28	M16	0.1
BT50-60°	38	23	17	25	85	45	35	M24	0.3
BT60-60°	56	32	24	31	115	65	53	M30	0.4
BT30-90°	16.5	11	7	12.5	43	23	18	M12	0.04
BT40-90°	23	15	10	17	60	35	28	M16	0.1
BT50-90°	38	23	17	25	85	45	35	M24	0.3
BT60-90°	56	32	24	31	115	65	53	M30	0.4

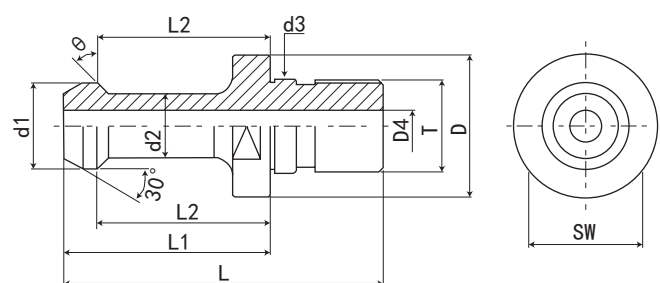

中心出水 Coolant

规格 / 型号 Model	D	D4	d1	d2	d3	L	L1	L2	T	重量 KGS
BT30-45° W	16.5	3	11	7	12.5	43	23	18	M12	0.04
BT40-45° W	23	4	15	10	17	60	35	28	M16	0.1
BT50-45° W	38	6	23	17	25	85	45	35	M24	0.3
BT60-45° W	56	14	32	24	31	115	65	53	M30	0.4
BT30-60° W	16.5	3	11	7	12.5	43	23	18	M12	0.04
BT40-60° W	23	4	15	10	17	60	35	28	M16	0.1
BT50-60° W	38	6	23	17	25	85	45	35	M24	0.3
BT60-30° W	56	14	32	24	31	115	65	53	M30	0.4
BT30-90° W	16.5	3	11	7	12.5	43	23	18	M12	0.04
BT40-90° W	23	4	15	10	17	60	35	28	M16	0.1
BT50-90° W	38	6	23	17	25	85	45	35	M24	0.3
BT60-90° W	56	14	32	24	31	115	65	53	M30	0.4

### 特点:

#### 普通级拉钉

- ◎材质: 40Cr
- ◎头部硬度: 46-50HRC
- ◎螺纹及其它部位硬度较低: 35±5HRC, (保护柄螺纹, 核心硬度可以抵御冲击)
- ◎精度: 0.02

#### 高精度加硬拉钉

- ◎材质: 20CrMnTi
- ◎头部硬度: 55-58HRC
- ◎螺纹及其它部位硬度较低: 35±5HRC, (保护柄螺纹, 核心硬度可以抵御冲击)
- ◎精度: 0.01
- ◎订购时请告知所需精度等级

### Features:

#### General level Pull stud

- ◎ Material:40Cr.
- ◎ Head hardness:46-50HRC.
- ◎ Thread hardness is a little low;35±5HRC, (Protect shank thread,core hardness can resist hit).
- ◎ Accuracy:0.02

#### High-precision Hard Pull stud

- ◎ Material:20CrMnTi.
- ◎ Head hardness:55-58HRC.
- ◎ Thread hardness is a little low;35±5HRC, (Protect shank thread,core hardness can resist hit).
- ◎ Accuracy:0.01
- ◎ Please inform the required precision when ordering.





全白带 O 型圈



全白



黑牙

A: 中心出水 Coolant

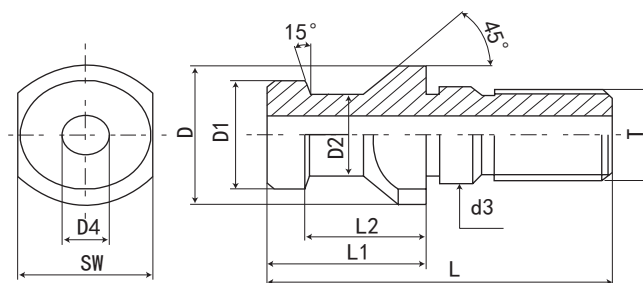

B: 标准型 Standard type

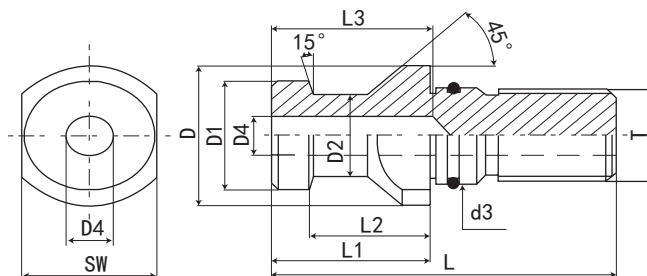

SK 标准与 JT 标准与 DAT 标准同属于 DIN 69872

SK=JT=DAT=DIN 69872

规格 / 型号 Model	D	D1	D2	d3	D4	L	L1	L2	L3	L4	SW
SK30A	17	13	9	13	-	44	24	19	-	-	14
SK40A	23	19	14	17	7	54	26	20	-	-	19
SK50A	36	28	21	25	11.5	74	34	25	-	-	30
SK60A	52	40	30	32	14	90	40	30	60	-	46
SK30B	17	13	9	13	-	44	24	19	-	2.3	14
SK40B	23	19	14	17	7	54	26	20	27	3	19
SK50B	36	28	21	25	11.5	74	34	25	37	4.5	30
SK60B	52	40	30	32	14	90	40	30	60	-	46

**特点:**

普通级拉钉

- ◎ 材质: 40Cr
- ◎ 头部硬度: 46-50HRC
- ◎ 螺纹及其它部位硬度较低: 35±5HRC, (保护柄螺纹, 核心硬度可以抵御冲击)
- ◎ 精度: 0.02

高精度加硬拉钉

- ◎ 材质: 20CrMnTi
- ◎ 头部硬度: 55-58HRC
- ◎ 螺纹及其它部位硬度较低: 35±5HRC, (保护柄螺纹, 核心硬度可以抵御冲击)
- ◎ 精度: 0.01
- ◎ 订购时请告知所需精度等级

**Features:**

General level Pull stud

- ◎ Material:40Cr.
- ◎ Head hardness:46-50HRC.
- ◎ Thread hardness is a little low;35±5HRC, (Protect shank thread,core hardness can resist hit).
- ◎ Accuracy:0.02

High-precision Hard Pull stud

- ◎ Material:20CrMnTi.
- ◎ Head hardness:55-58HRC.
- ◎ Thread hardness is a little low;35±5HRC, (Protect shank thread,core hardness can resist hit).
- ◎ Accuracy:0.01
- ◎ Please inform the required precision when ordering.

# 刀柄配件系列 HOLDER ACCESSORIES

## 马扎克、三井系列拉钉 MAZAK MITSUI

Mazak Mitsui serial pull studs MAZAK MITSUI



全白



黑牙

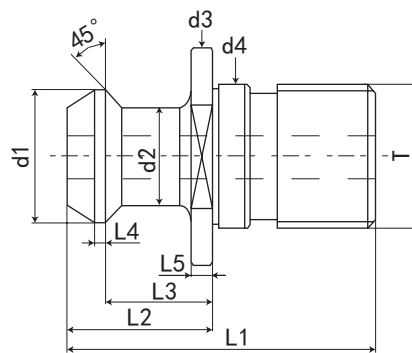
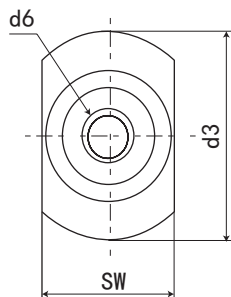

规格 / 型号 Model	d1	d2	d3	d4	T	d6	L1	L2	L3	L4	L5	SW	重量 KGS
MAZAK-BT40	18.8	12.45	22	17	M16	7	44.1	19.1	14.02	2	3	19	0.05
MAZAK-BT50	29	20.83	37	25	M24	10	65.2	25.2	17.7	2.5	5	30	0.18
MAZAK-CAT40	18.8	12.45	22	17	M16	7	41.1	16.1	11	2	3	19	0.05
MITSUMI-BT40	15	10	23	17	M16	-	51	25	18	3	6	19	0.06
MITSUMI-BT50	24	18	36	25	M24	-	57	31	23	5	10	30	0.19

## 美国标准拉钉 ANSI/AMSE B5.50-1994

AMERICAN STANDARD PULL STUD ANSI/AMSE B5.50-1994



全白



黑牙

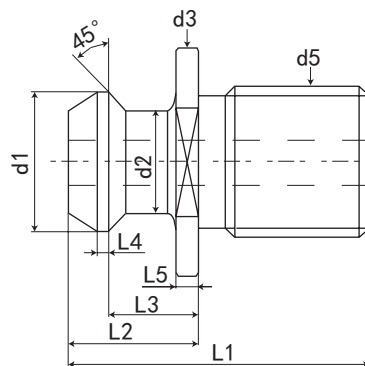
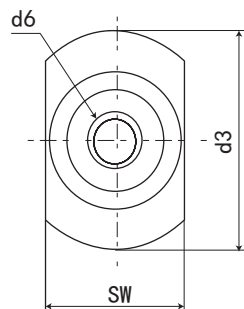

规格 / 型号 Model	d1	d2	d3	d5	d6	L1	L2	L3	SW	重量 KGS
CAT40-A45° U	18.8	12.4	23.8	5/8"-11UNC	-	38.1	16.2	11.2	19.05	0.04
CAT40-A45° U/T	18.8	12.4	23.8	5/8"-11UNC	7.1	38.1	16.2	11.2	19.05	0.03
对应英制尺寸 inch	0.74	0.49	0.94		0.281	1.5	0.64	0.44	0.75	
CAT50-A45° U	28.9	20.8	36.5	1"-8UNC	-	58.4	25.4	17.7	31.75	0.17
CAT50-A45° U/T	28.9	20.8	36.5	1"-8UNC	11.9	58.4	25.4	17.7	31.75	0.16
对应英制尺寸 inch	1.14	0.82	1.44		0.468	2.3	1	0.7	1.25	
CAT40-A45°	18.8	12.4	23.8	M16*2.0P	-	38.1	16.2	11.2	19.05	0.04
CAT40-A45° /T	18.8	12.4	23.8	M16*2.0P	7.1	38.1	16.2	11.2	19.05	0.03
对应英制尺寸 inch	0.74	0.49	0.94		0.281	1.5	0.64	0.44	0.75	
CAT50-A45°	28.9	20.8	36.5	M24*3.0P	-	58.4	25.4	17.7	31.75	0.17
CAT50-A45° /T	28.9	20.8	36.5	M24*3.0P	11.9	58.4	25.4	17.7	31.75	0.16
对应英制尺寸 inch	1.14	0.82	1.44		0.468	2.3	1	0.7	1.25	

### 特点:

#### 普通级拉钉

- ◎ 材质: 40Cr
  - ◎ 头部硬度: 46-50HRC
  - ◎ 螺纹及其它部位硬度较低: 35±5HRC, (保护柄螺纹, 核心硬度可以抵御冲击)
  - ◎ 精度: 0.02
- #### 高精度加硬拉钉
- ◎ 材质: 20CrMnTi
  - ◎ 头部硬度: 55-58HRC
  - ◎ 螺纹及其它部位硬度较低: 35±5HRC, (保护柄螺纹, 核心硬度可以抵御冲击)
  - ◎ 精度: 0.01
  - ◎ 订购时请告知所需精度等级

### Features:

#### General level Pull stud

- ◎ Material:40Cr.
  - ◎ Head hardness:46-50HRC.
  - ◎ Thread hardness is a little low;35±5HRC, (Protect shank thread,core hardness can resist hit).
  - ◎ Accuracy:0.02
- #### High-precision Hard Pull stud
- ◎ Material:20CrMnTi.
  - ◎ Head hardness:55-58HRC.
  - ◎ Thread hardness is a little low;35±5HRC, (Protect shank thread,core hardness can resist hit).
  - ◎ Accuracy:0.01
  - ◎ Please inform the required precision when ordering.

## 国际标准拉钉 A 型 ISO 7388/2-1984

INTERNATIONAL STANDARD PULL STUD A TYPE ISO 7388/2-1984

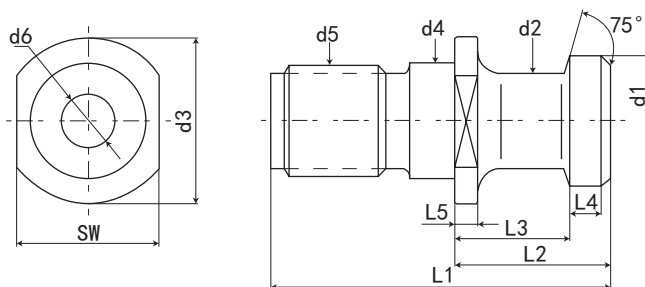

规格 / 型号 Model	d1	d2	d3	d4	d5	d6	L1	L2	L3	L4	L5	SW	重量 KGS
LDA30	12	8	18	13	M12	-	44	24	19	3	4	13	0.04
LDA40	19	14	23	17	M16	-	54	26	20	4	4	19	0.08
LDA40/T	19	14	23	17	M16	7.5	54	26	20	4	4	19	0.06
LDA50	28	21	36	25	M24	-	74	34	25	7	5	30	0.23
LDA50/T	28	21	36	25	M24	11.5	74	34	25	7	5	30	0.2
LDA60	40	30	52	32	M30	-	90	40	30	8	6	46	0.53
LDA60/T	40	30	52	32	M30	14	90	40	30	8	6	46	0.51

## 国际标准拉钉 B 型 ISO 7388/2-1984

INTERNATIONAL STANDARD PULL STUD B TYPE ISO 7388/2-1984



全白



黑牙

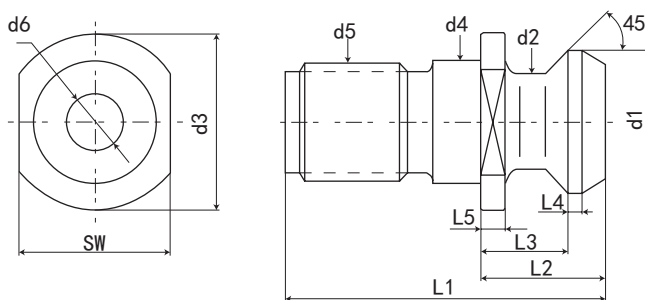

规格 / 型号 Model	d1	d2	d3	d4	d5	d6	L1	L2	L3	L4	L5	SW	重量 KGS
LDB30	13.3	9.3	18	13	M12	-	27	11.8	8.15	1.25	2.75	13	0.04
LDB40	18.95	12.95	23	17	M16	-	44.5	16.4	11.15	1.75	3.25	19	0.07
LDB40/T	18.95	12.95	23	17	M16	7.5	44.5	16.4	11.15	1.75	3.25	19	0.053
LDB50	29.1	19.6	36	25	M24	-	65.5	25.55	17.95	2.75	5.25	30	0.24
LDB50/T	29.1	19.6	36	25	M24	11.5	65.5	25.55	17.95	2.75	5.25	30	0.18
LDB60	37.25	25	50	32	M30	-	95	38.15	27.65	3.75	7.75	38	0.55
LDB60/T	37.25	25	50	32	M30	14	95	38.15	27.65	3.75	7.75	38	0.44

### 特点:

#### 普通级拉钉

- ◎ 材质: 40Cr
  - ◎ 头部硬度: 46-50HRC
  - ◎ 螺纹及其它部位硬度较低: 35±5HRC, (保护柄螺纹, 核心硬度可以抵御冲击)
  - ◎ 精度: 0.02
- #### 高精度加硬拉钉
- ◎ 材质: 20CrMnTi
  - ◎ 头部硬度: 55-58HRC
  - ◎ 螺纹及其它部位硬度较低: 35±5HRC, (保护柄螺纹, 核心硬度可以抵御冲击)
  - ◎ 精度: 0.01
  - ◎ 订购时请告知所需精度等级

### Features:

#### General level Pull stud

- ◎ Material: 40Cr.
  - ◎ Head hardness: 46-50HRC.
  - ◎ Thread hardness is a little low; 35±5HRC, (Protect shank thread, core hardness can resist hit).
  - ◎ Accuracy: 0.02
- #### High-precision Hard Pull stud
- ◎ Material: 20CrMnTi.
  - ◎ Head hardness: 55-58HRC.
  - ◎ Thread hardness is a little low; 35±5HRC, (Protect shank thread, core hardness can resist hit).
  - ◎ Accuracy: 0.01
  - ◎ Please inform the required precision when ordering.

# 刀柄配件系列 HOLDER ACCESSORIES

## 混合标准拉钉 CAT-BT

## BLENDED STANDARD PULL STUD CAT-BT



全白

白牙

黑牙

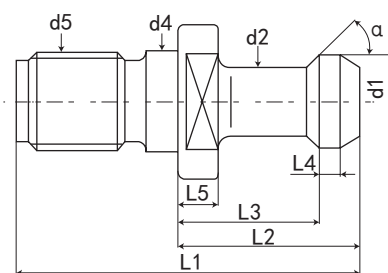
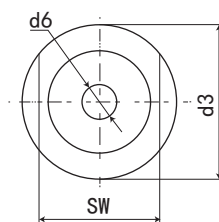

CT 美制螺纹拉钉 CT AMERICAN STANDARD SCREW THREAD PULLSTUD

规格 / 型号 Model	d1	d2	d3	d5	d6	L1	L2	L3	SW	$\alpha$	重量 KGS
CAT40-45° U	15	10	23	5/8"-11UNC	-	57	32	25	19	45°	0.07
CAT40-45° U/T					4					45°	0.06
CAT40-60° U					-					60°	0.07
CAT40-60° U/T					4					60°	0.06
CAT40-90° U					-					90°	0.07
CAT40-90° U/T					4					90°	0.06
对应英制尺寸 inch	0.59	0.394	0.905		0.157	2.25	1.266	0.99	0.748		
CAT50-45° U	23	17	38	1"-8UNC	-	78.6	45	35	30	45°	0.26
CAT50-45° U/T					8.5					45°	0.22
CAT50-60° U					-					60°	0.26
CAT50-60° U/T					8.5					60°	0.22
CAT50-90° U					-					90°	0.26
CAT50-90° U/T					8.5					90°	0.22
对应英制尺寸 inch	0.906	0.669	1.496		0.334	3.094	1.771	1.378	1.181		

CAT BT 公制螺纹拉钉 CAT-BT METRIC THREAD PULL STUD

规格 / 型号 Model	d1	d2	d3	d4	d5	d6	L1	L2	L3	SW	$\alpha$	重量 KGS
CAT40*45°	15	10	23	17	M16	-	57	32	25	19	45°	0.07
CAT40*45° /T						4					45°	0.06
CAT40*60°						-					60°	0.07
CAT40*60° /T						4					60°	0.06
CAT40*90°						-					90°	0.07
CAT40*90° /T						4					90°	0.06
对应英制尺寸 inch	0.59	0.394	0.905	0.512		0.157	2.25	1.266	0.99	0.748		

### 特点:

#### 普通级拉钉

- ◎ 材质: 40Cr
  - ◎ 头部硬度: 46-50HRC
  - ◎ 螺纹及其它部位硬度较低: 35±5HRC, (保护柄螺纹, 核心硬度可以抵御冲击)
  - ◎ 精度: 0.02
- #### 高精度加硬拉钉
- ◎ 材质: 20CrMnTi
  - ◎ 头部硬度: 55-58HRC
  - ◎ 螺纹及其它部位硬度较低: 35±5HRC, (保护柄螺纹, 核心硬度可以抵御冲击)
  - ◎ 精度: 0.01
  - ◎ 订购时请告知所需精度等级

### Features:

#### General level Pull stud

- ◎ Material: 40Cr.
  - ◎ Head hardness: 46-50HRC.
  - ◎ Thread hardness is a little low; 35±5HRC, (Protect shank thread, core hardness can resist hit).
  - ◎ Accuracy: 0.02
- #### High-precision Hard Pull stud
- ◎ Material: 20CrMnTi.
  - ◎ Head hardness: 55-58HRC.
  - ◎ Thread hardness is a little low; 35±5HRC, (Protect shank thread, core hardness can resist hit).
  - ◎ Accuracy: 0.01
  - ◎ Please inform the required precision when ordering.

## 昆机镗床专用拉钉 ST50

KUNMING MACHINE BORING MACHINE SPECIAL-PURPOSE PULL STUD ST50

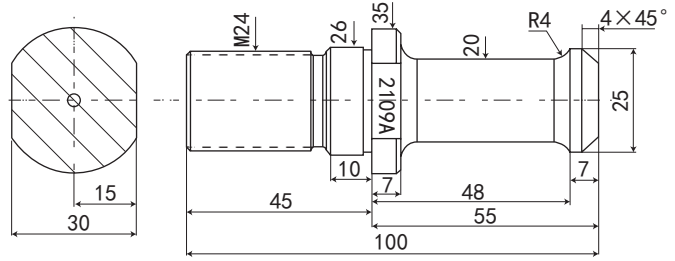

图示 Icon



### 特点:

昆机拉钉图号: TX11C-3002-034 T6113A-21092A  
 适配: 主轴锥孔 ISO50; 刀柄 GB3837 标准  
 (中国标准 ST50/XT50; 德国标准 NT50)  
 昆机采用本图拉钉的机床: TX6111D TX6111C/2 TX6111C/3  
 TX6113A/2

### Features:

Kunming Machine Pull Stud Model: TX11C-3002-034 T6113A-21092A  
 Adaptor standard: spindle taper hole-ISO50; skank-GB3837  
 (Chinese standard-ST50/XT50; German standard-NT50)  
 Suitable for TX6111D TX6111C/2 TX6111C/3 TX6113A/2

HOLDER  
ACCESSORIES  
刀柄  
配件

## 昆机镗床专用拉钉 BT50-ST50

KUNMING MACHINE BORING MACHINE SPECIAL-PURPOSE PULL STUD BT50-ST50

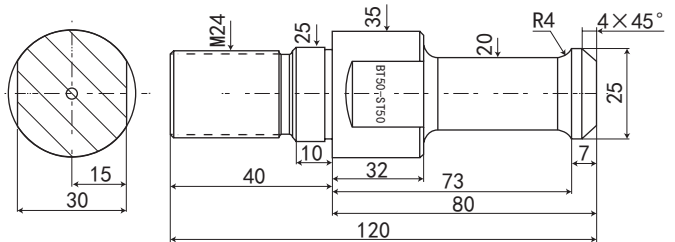

图示 Icon



### 特点:

此款拉钉适用于日本标准 BT50; 中国标准 JT50; 德国标准 DIN69872-50 的刀柄, 在以下型号的昆机镗床上使用  
 昆机采用本图拉钉的机床: TX6111D TX6111C/2 TX6111C/3  
 TX6113A/2

### Features:

This pull stud is suitable for the shank of Japanese standard BT50; Chinese standard JT50; German standard DIN69872-50. Suitable for the boring machine of TX6111D TX6111C/2 TX6111C/3 TX6113A/2

# 刀柄配件系列 HOLDER ACCESSORIES

## 日本 JIS B6339 拉钉

JAPAN JIS B6339 PULL STUD

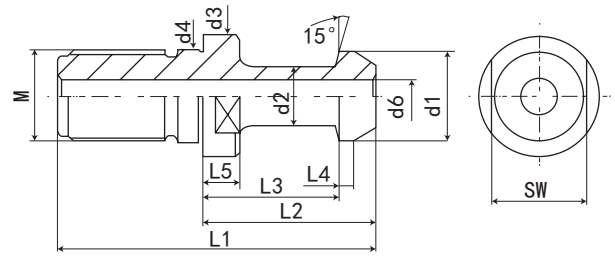

规格 / 型号 Model	d1	d2	d3	d4	M	d6	L1	L2	L3	L4	L5	SW	重量 KGS
30P	12	8	16.5	12.5C	M12*1.75P	-	43	23.4	18.4	3	5	13	0.03
40P	19	14	23	17	M16*2.0P	7	54	29	23	3	7	19	0.08
50P	28	21	38	25	M24*3.0P	10	74	34	25	5	7	30	0.24

## SR 拉钉

SR PULL STUD

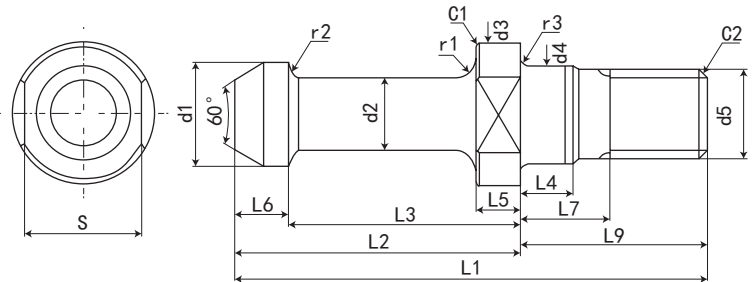

规格 / 型号 Model	L1	d4 h7	d5 6g	C2	r3 (最大)	L4	L7	d3 0 -0.1	r1	L5 0 -0.1	s 0 -0.2	C1
S5R	23.5	5.5	M5	0.5	0.4	3	5	8	1	2.5	7	0.2
S10R	26.5	6.5	M6	0.5	0.4	3	5	10	1.5	3	8	0.3
S15R	32	8.5	M8	1	0.5	4	6	12	1.5	3.5	10	0.4
S20R	34.5	8.5	M8	1	0.5	4	6	14	1.8	4	10	0.5
S25R	40	10.5	M10	1	0.5	4	7	15.5	2	4.5	13	0.5

规格 / 型号 Model	d1 0 -0.1	d2 0 -0.1	L2 0 -0.1	L3 0 -0.1	L6	r2	Φ		L3-L5	L9	CHUCK
							1形	2形			
S5R	5.8	4	13.5	10.5	1.4	0.3			8	10	S5T
S10R	7	5	15.5	12	1.6	0.3	+0.5°	+0.5°	9	11	S10T
S15R	8.3	6	18	14	1.9	0.4	0	0	10.5	14	S15T
S20R	9.5	7	20.5	16	2.1	0.4	15°	0°	12	14	S20T
S25R	10.8	8	23	18	2.3	0.5			13.5	17	S25T

## ISO 雕刻机用拉钉

PULL STUD OF CARVING MACHINE



全白



全黑

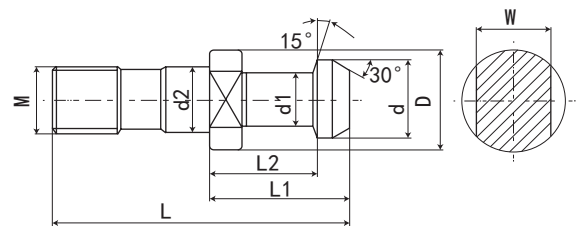

规格 / 型号 Model	D	d	d1	d2	L	L1	L2	W	M
ISO20	11.4	9	6	8.5	26	12	9	10	M8*1.25P
ISO25	12	10	7	9	32	16	11.6	10	M8*1.25P
ISO30	17	13	9	13	45	24	19	14	M12*1.75P

# 无扁尾莫氏圆锥孔刀柄加长拉钉

## ADAPTOR SLEEVES FOR MORSE TAPER WITHOUT TANG

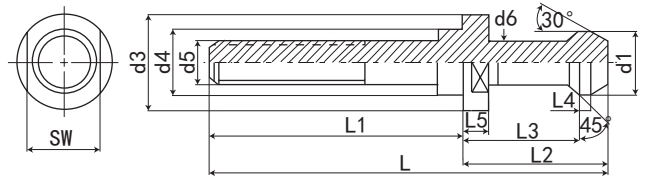

规格 / 型号 Model	d1	d2	d3	d4	d5	d6	L	L1	L2	L3	L4	L5	SW	重量 KGS
BT30-45° -M10	11	7	16.5	12.5	M10	7	90	67	23	18	2	5	13	0.06
BT30-45° -M12	11	7	16.5	12.5	M12	7	90	67	23	18	2	5	13	0.06
BT40-45° -M10	15	10	23	17	M10	10	115	80	35	28	2.7	6	19	0.1
BT40-45° -M12	15	10	23	17	M12	10	115	80	35	28	2.7	6	19	0.1
BT40-45° -M14	15	10	23	17	M14	10	115	80	35	28	2.7	6	19	0.15
BT40-45° -M16	15	10	23	17	M16	10	115	80	35	28	2.7	6	19	0.15
BT50-45° -M10	23	17	38	25	M10	17	170	125	45	35	5	10	30	0.3
BT50-45° -M12	23	17	38	25	M12	17	170	125	45	35	5	10	30	0.35
BT50-45° -M14	23	17	38	25	M14	17	170	125	45	35	5	10	30	0.35
BT50-45° -M16	23	17	38	25	M16	17	170	125	45	35	5	10	30	0.35
BT50-45° -M20	23	17	38	25	M20	17	170	125	45	35	5	10	30	0.4
BT60-45° -M24	32	24	56	31	M24	24	238	172	65	53	6	14	41	1

# 螺丝

## SCREW

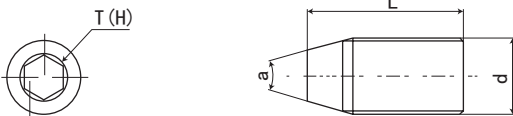
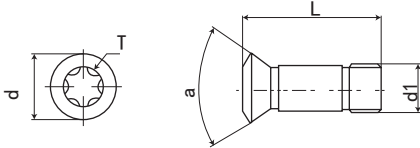
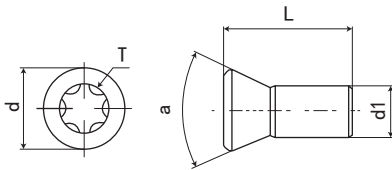

规格 / 型号 Model	尺寸 (mm)				
	d	d1	L	a	T(H)
M2*4	2.7	2	3.7	55°	6
M2*5	2.7	2	5	55°	6
M2.2*5	3	2.2	4.8	55°	8
M2.5*5	3.5	2.5	5.5	55°	8
M2.5*6	3.5	2.5	6	55°	8
M3*6	4	3	6.5	55°	10
M3*7	4	3	7	55°	10
M3.5*8	5.2	3.5	8.5	55°	15
M4*8	5.5	4	8.5	55°	15
M4*9	5.5	4	9	55°	15
M4*10	6	4	10	55°	15
M4*11	5.5	4	11	55°	15
M5*11	7.2	5	11	55°	15
M5*12	7.2	5	12	55°	20
M3*7B	4.5	3	7	60°	8
M3*10B	4.5	3	10	60°	8
M3.5*8B	5.2	3.5	8	60°	15
M4*8B	5.7	4	8.2	60°	15
M4*10B	5.7	4	10	60°	15
M5*12B	7.2	5	12	60°	20

规格 / 型号 Model	尺寸 (mm)			
	d1	L	a	T(H)
AHV0507-2.5	5	7	60°	2.5
AHV0608-3	6	8	60°	3
AHV0811-4	8	11	60°	4
AHV1014-5	10	14	60°	5
AHV1218-6	12	18	60°	6

# 刀柄配件系列 HOLDER ACCESSORIES

## 扳手

### SPANNER

ER-A 型扳手 ER-A SPANNER

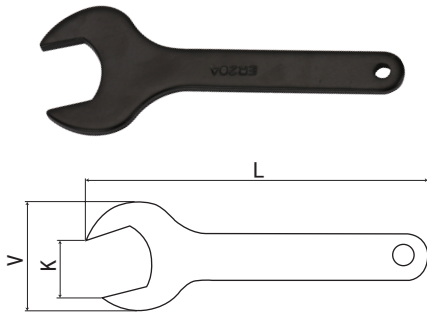

规格 / 型号 Model	螺帽外径 Nut diameter	L	V	K
ER11-A	19	110	40	17
ER16-A	28	120	53	25
ER20-A	34	130	60	30

ER-M 型扳手 ER-M SPANNER

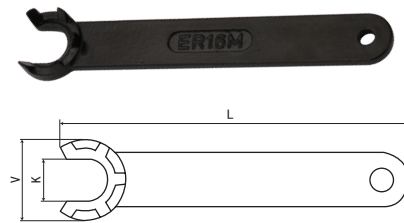

规格 / 型号 Model	螺帽外径 Nut diameter	L	V	K
ER8-M	12	70	12	7.5
ER11-M	16	90	17	11
ER16-M	22	110	23	15
ER20-M	28	120	29	19.5
ER25-M	35	130	36	25

ER-UM 型扳手 ER-UM SPANNER

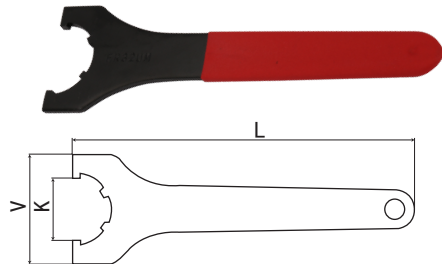

规格 / 型号 Model	螺帽外径 Nut diameter	L	V	K
ER16-UM	32	180	40	26
ER20-UM	35	190	55	30
ER25-UM	42	210	60	35
ER32-UM	50	250	72	45
ER40-UM	63	290	86	58
ER50-UM	78	350	105	73

勾头扳手 HOOK HEAD SPANNER

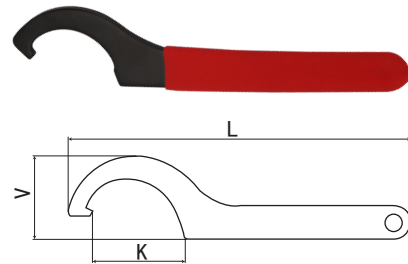

规格 / 型号 Model	适用刀柄及螺帽 Apple holder and nut	L
18-21	EOC6	90
22-26	EOC8	125
28-32	EOC10	140
34-36	EOC12	154
38-42	EOC16 7316A APU08	168
45-52	EOC20 ER25-UM 7316B APU13	190
55-62	EOC25 ER32-UM APU13 APU16 C20 C22 C25	210
68-72	EOC32 ER40-UM	230
78-85	EOC40 C32 ER50-UM	240
100-110	EOC50 C42 JXT25-50	250

滚珠扳手 BALL SPANNER

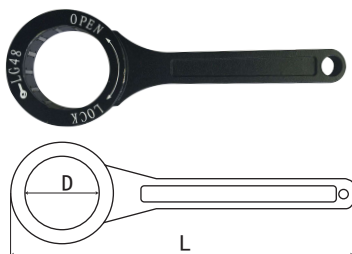

规格 / 型号 Model	规格 Specifications	D	L
WH-GSK06	GSK06	19.5	120
WH-GSK10	GSK10	30	152.5
WH-GSK16	GSK16	40	200
WH-GSK20	GSK20	48	200
WH-GSK25	GSK25	55	210
WH-GER16	GER16	30	150
WH-GER20	GER20	35	160
WH-GER25	GER25	40	181
WH-GER32	GER32	50	200



# 扳手

## SPANNER

螺丝刀 B o l t driver	形状 Shape	型号 Model	Torx(梅花) 尺寸
		KDT-T06N	T6
		KDT-T07N	T7
		KDT-T08N	T8
		KDT-T09N	T9
		KDT-T10N	T10
		KDT-T15N	T15
		KDT-T20N	T20

旗形扳手	形状 Shape	型号 Model	Torx(梅花) 尺寸
		KWT-T07	T7
		KWT-T08	T8
		KWT-T09	T9
		KWT-T10	T10
		KWT-T15	T15
		KWT-T20	T20
		KFT-T06	T6
		KFT-T07	T7
		KFT-T08	T8
		KFT-T09	T9
		KFT-T10	T10
		KFT-T15	T15
		KFT-T20	T20

T 形扳手	形状 Shape	型号 Model	Torx(梅花) 尺寸
		KTTL-T15	T15
		KTTL-T20	T20
		KTTS-T20	T20
		KTTS-T25	T25

L 形扳手	形状 Shape	型号 Model	Torx(梅花) 尺寸
		KWH2.0L	H2
		KWH2.5L	H2.5
		KWH3.0L	H3
		KWH3.5L	H3.5
		KWH4.0L	H4
	KWH5.0L	H5	



HOLDER  
ACCESSORIES  
手柄  
配件

# 刀柄配件系列 HOLDER ACCESSORIES

## 高精度 ER 螺帽

## HIGH PRECISION ER NUT

刀柄配件  
HOLDER  
ACCESSORIES



形式 Type	型号 Model No.	D	L	T
A	ER8A	13.5	11	M10*0.75P
	ER11A	19	11.3	M14*0.75P
	ER16A	28	17.5	M22*1.5P
	ER20A	34	19	M25*1.5P
M	ER8M	12	11	M10*0.75P
	ER11M	16	12	M13*0.75P
	ER16M	22	18	M19*1.0P
	ER20M	28	19	M24*1.0P
	ER25M	35	20	M30*1.0P
UM/RD	ER16UM	32	17	M22*1.5P
	ER20UM	35	19	M25*1.5P
	ER25UM	42	20	M32*1.5P
	ER32UM	50	22.5	M40*1.5P
	ER40UM	63	25.5	M50*1.5P
	ER50UM	78	35.5	M64*2.0P
KM/RD	ER25KM	42	20	M32*1.5P
	ER32KM	50	22.5	M40*1.5P
	ER40KM	63	25.5	M50*1.5P
	ER50KM	78	35.5	M64*2.0P
MS	ER11MS	16	11.3	M13*0.75P
	ER16MS	22	17	M19*1.0P
	ER20MS	28	19	M24*1.0P
	ER25MS	35	23	M30*1.0P
GER	GER16	30	23	M19*1.0P
	GER20	35	25	M24*1.0P
	GER25	40	26	M30*1.0P
	GER32	50	30	M40*1.5P

形式 Type	型号 Model No.	D	L		T
			Fig1	Fig2	
GSK	GSK6	19.5	15	21	M15.5*1
	GSK10	27.5	17	24	M21.5*1
	GSK16	40	24	31	M32*1.5
	GSK20	48	27	35	M40*1.5
	GSK25	50	30	37	M40*1.5

### 压帽与卡簧的安装

### Mounting instructio for ER collets and nuts

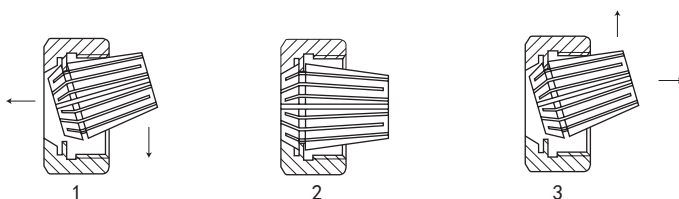

- ◎将夹头放入压帽内，轻轻转动卡簧，待压帽偏心部分凹入卡槽内，沿箭头方向均匀用力推动卡簧，即可装入压帽内
- ◎将卡簧和压帽一起安装在夹头体或机床主轴内，把刀具圆柱柄部控净后装入夹持孔内，使用扳手均匀用力紧固压帽直到刀具夹牢为止方可使用。（注意：切忌在未安装刀具状态下紧固压帽，以免损坏夹头）
- ◎换刀时，用扳手松开压帽带出夹头及刀具，卸下刀具，沿箭头方向用力推动卡簧，使其退出，然后根据需要换上其它孔径的卡簧即可
- ◎ Put the collet into the nut,turn the collet slightly.Push it into the nut at the offered direction evenly when the offset flange sinks into the undercut of the collet
- ◎ Fix the nut and the collet on the spindle rotate the nut until the collet is in pressing,wipe the straight shank of cutter,and instert it into the pilot hole.Tighten the nut with a wrench till the cutter is clamped heavily (Caution:never tighten the nut without cutter in it for it will break)
- ◎ When changing the tool.Loosen the nut and it shall bring out the collet and the cutter together.And the draw the cutter out push out slightly the collet in the offered direction,it shall be ready for any change of the cutter.

# 光电式寻边器

## HIGH SENSITIVE ELECTRONIC EDGE SENSOR

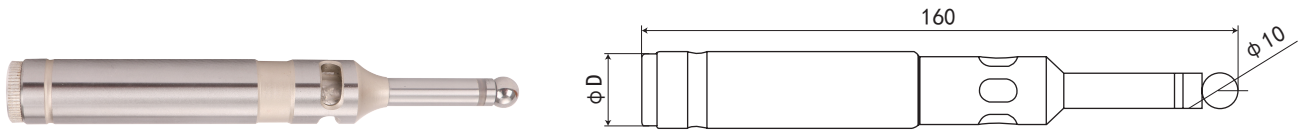

名称	型号	规格	D
光电式寻边器	ES-20	Φ20	20
	ES-32	Φ32	32

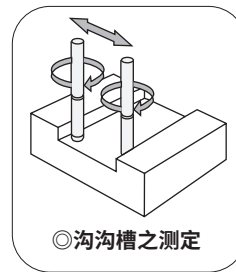
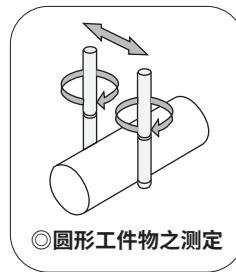
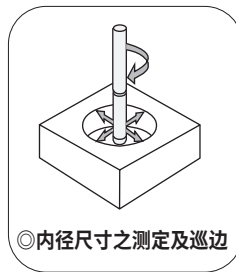
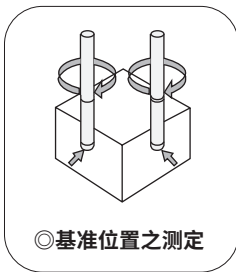
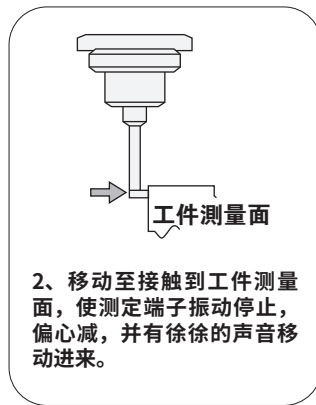
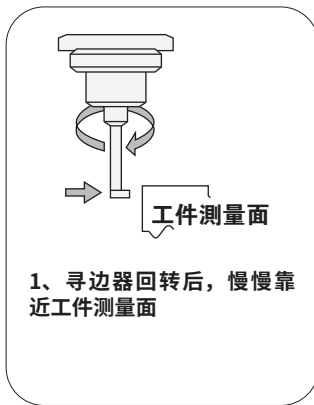

### 特点:

- ◎使用 2 攻 UM5#1.5V 电池
- ◎红灯亮时同时发出电子音，哔！哔！声响
- ◎对无法目视深孔探测，可由声音得知探测结果

### Features:

- ◎ 2 pieces battery(UM5#15V)
- ◎ The red light on with electronic sound
- ◎ According to the sound for deep hole testing



# 刀柄配件系列 HOLDER ACCESSORIES

## 机械式寻边器

## MACHINE EDGE FINDER

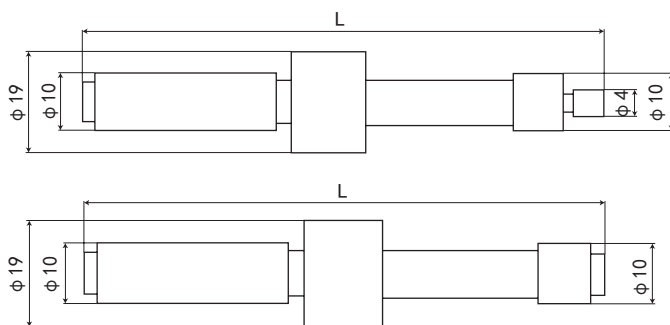

名称	型号	规格	D
偏心式寻边器	ME-1020	Φ10	82
	ES-420	Φ10+4	90

### 特点:

- ◎适用在铣床和 CNC 加工机,可测量设定工件的 X、Y 轴坐标
- ◎设计 4mm 的测头,供小孔径及偏窄沟槽使用
- ◎配合转速 400-600RPM 使用

### Features:

- ◎ Suitable for milling machines and CNC machining machines, can test the X、Y coordinator of work place.
- ◎ 4mm gauge head for the use of small diameter and narrow groove.
- ◎ Forrev 400-600 RPM.

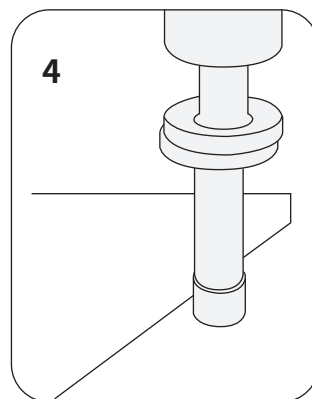
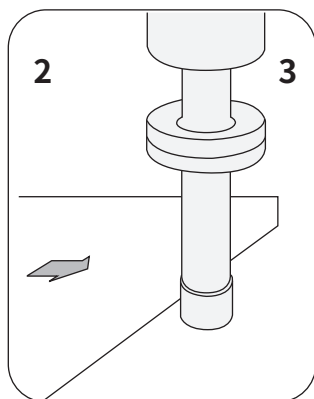
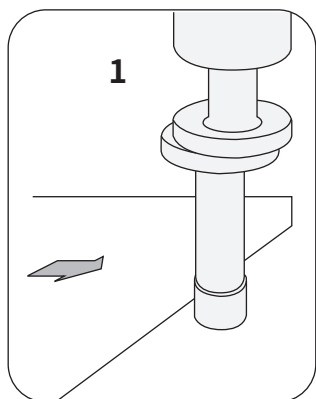

### 使用方法图示:

- ◎寻边器每分钟 500 转,并移动至工件测量面
- ◎寻边器移动至接触到工件测量面,使心轴偏心递减
- ◎当心轴结合在一起,并开始测出中心时,此时坐标既为心轴的半径
- ◎心轴已滑出中心点,此时心轴偏心递增

### Usage method locn:

- ◎ 500 circles/minuts, move to the workplace surface.
- ◎ When it moved to the workplace surface, declines mandrel departure.
- ◎ When mandrel get together, and begin to skid off the center, then the coordinate is the radius of mandrel.
- ◎ Mandrel departure increases when mandrel skids off the center.



## HSK 锁刀座

## HSK TOOL TIGHTENING FIXTURE

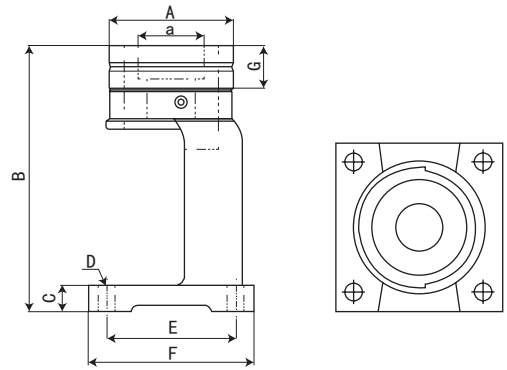

规格 / 型号 Model	a	A	B	C	D	E	F	G	重量
HSK-32	32.5	78	168	16.2	10.5	81	104	25	2.04
HSK-40	40.5	78	168	16.2	10.5	81	104	25	1.94
HSK-50	50.5	78	168	16.2	10.5	81	104	25	1.66
HSK-63	63.5	82.5	168	16.2	10.5	81	104	25	1.38
HSK-100	100.5	128.2	168	18.4	10.5	99.5	135.8	25	5.49
HG BT30	32	76	168	16.2	10.5	81	104	25	1.08
HG BT40	44	76	168	16.2	10.5	81	104	25	0.98

HOLDER  
ACCESSORIES  
刀柄配件

## HSK 锁刀座

## HSK TOOL TIGHTENING FIXTURE

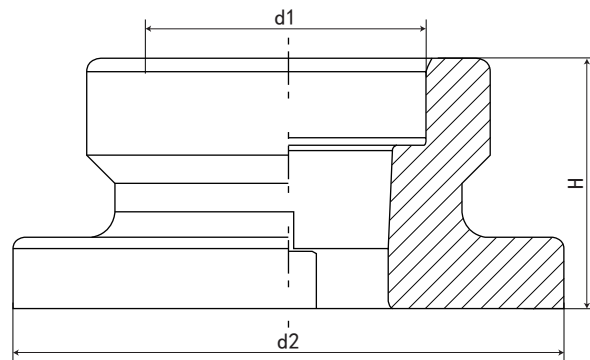

规格 / 型号 Model	d1 (mm)	d2 (mm)	H (mm)	重量
HSK63A	63	130	66	1.2
HSK100A	100	180	85	2.6

# 刀柄配件系列 HOLDER ACCESSORIES

## BT 锁刀座

## BT TOOL TIGHTENING FIXTURE

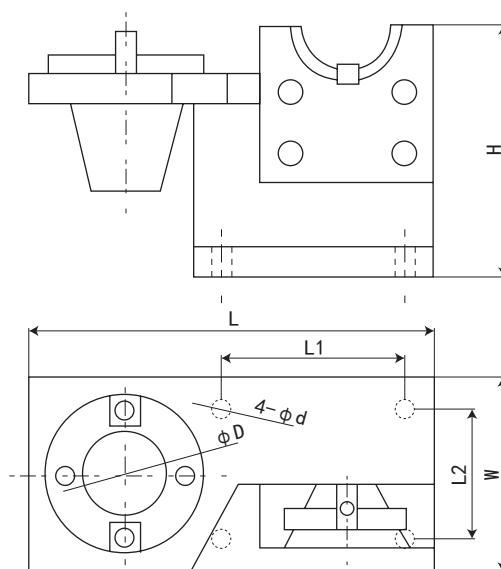

规格 / 型号 Model	L	L1	L2	W	H	D	d
BT30	210	95	67	100	130	31.75	8.5
BT40	210	95	67	100	130	44.45	8.5
BT50	275	113	105	138	200	69.85	13

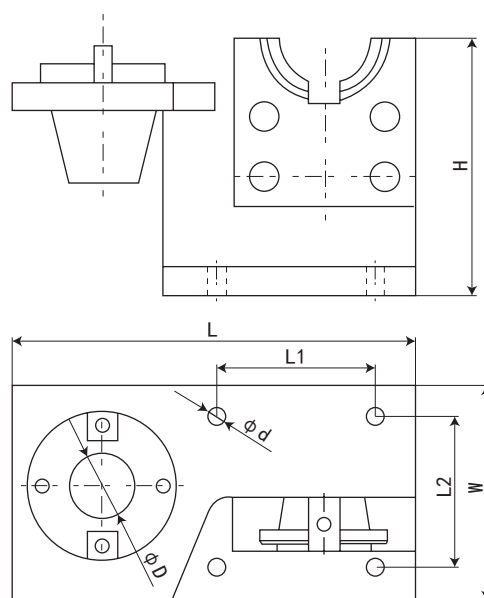

规格 / 型号 Model	L	L1	L2	W	H	D	d
JT40	210	95	67	100	130	44.45	8.5
JT50	275	113	105	138	200	69.85	13

## C-ER 直柄延长杆

## C-ER STRAIGHT SHANK COLLET CHUCK AND EXTENSION TYPE

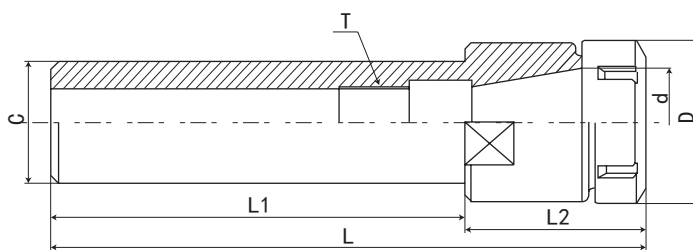

P.131



P.106



P.133

规格 / 型号 Model	L	L1	L2	D	d	C	T
C8-ER11A-100L	116.6	100	16.6	19	11	8	M5×0.8P
C8-ER11M-100L	116.6	100	16.6	16	11	8	M5×0.8P
C10-ER8M-100L	115	100	15	12	11	10	M6×1.0P
C10-ER8M-150L	165	150	15	12	11	10	M6×1.0P
C10-ER11A-100L	116.6	100	16.6	19	11	10	M6×1.0P
C10-ER11A-150L	166.6	150	16.6	19	11	10	M6×1.0P
C10-ER11M-100L	116.6	100	16.6	16	11	10	M6×1.0P
C10-ER11M-150L	166.6	150	16.6	16	11	10	M6×1.0P
C12-ER11A-100L	116.6	100	16.6	19	11	12	M8×1.25P
C12-ER11A-150L	166.6	150	16.6	19	11	12	M8×1.26P
C12-ER11M-100L	116.6	100	16.6	16	11	12	M8×1.27P
C12-ER11M-150L	166.6	150	16.6	16	11	12	M8×1.28P
规格 / 型号 Model	L	L1	L2	D	d	C	T
C16-ER11A-100L	116.6	100	16.6	19	11	16	M10×1.5P
C16-ER11A-150L	166.6	150	16.6	19	11	16	M10×1.5P
C16-ER11M-100L	116.6	100	16.6	16	11	16	M10×1.5P
C16-ER11M-150L	166.6	150	16.6	16	11	16	M10×1.5P
C16-ER16A-100L	140	100	40	28	16	16	M10×1.5P
C16-ER16A-150L	190	150	40	28	16	16	M10×1.5P
C16-ER16A-200L	240	200	40	28	16	16	M10×1.5P
C16-ER16M-100L	140	100	40	22	16	16	M10×1.5P
C16-ER16M-150L	190	150	40	22	16	16	M10×1.5P
C16-ER16M-200L	240	200	40	22	16	16	M10×1.5P
C16-ER20A-100L	140.5	100	40.5	34	20	16	M10×1.5P
C16-ER20A-150L	190.5	150	40.5	34	20	16	M10×1.5P
C16-ER20M-100L	140.5	100	40.5	28	20	16	M10×1.5P
C16-ER20M-150L	190.5	150	40.5	28	20	16	M10×1.5P

### 特点:

- ◎ 材质 20CrMnTi/15CrMo, 表面硬度在 52-55HRC, 心部硬度 40-45HRC
- ◎ ER 直柄延长杆, 柄体较长, 适合于深孔加工
- ◎ 延长杆外径与其他部位都经过研磨, 消除不平衡余量, 利于切削的稳定性
- ◎ 可减少对加长刀具的选用, 可降低成本, 提高效率
- ◎ 精度 :0.005mm

### Features:

- ◎ Material:20CrMnTi, Surface hardness:52-55HRC, Shank hardness:40-45HRC.
- ◎ Shank is longer, suitable for deep hole processing.
- ◎ Outer diameter and other parts after grinding, eliminate the unbalanced allowance, conducive to the stability of the cutting.
- ◎ Can reduce to the selection of lengthen cutting tool, reduce cost and improve efficiency.
- ◎ Precision:0.005mm.

# 刀柄配件系列 HOLDER ACCESSORIES

## C-ER 直柄延长杆

## C-ER STRAIGHT SHANK COLLET CHUCK AND EXTENSION TYPE

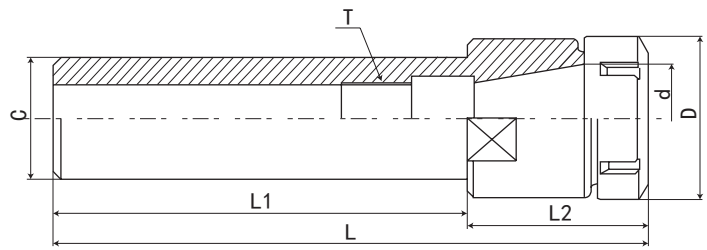

规格 / 型号 Model	L	L1	L2	D	d	C	T
C20-ER16A-100L	140	100	40	28	16	20	M12×1.75P
C20-ER16A-150L	190	150	40	28	16	20	M12×1.75P
C20-ER16A-200L	240	200	40	28	16	20	M12×1.75P
C20-ER16M-100L	140	100	40	22	16	20	M12×1.75P
C20-ER16M-150L	190	150	40	22	16	20	M12×1.75P
C20-ER16M-200L	240	200	40	22	16	20	M12×1.75P
C20-ER20A-100L	140.5	100	40.5	34	20	20	M12×1.75P
C20-ER20A-150L	194.5	150	40.5	34	20	20	M12×1.75P
C20-ER20A-200L	240.5	200	40.5	34	20	20	M12×1.75P
C20-ER20A-250L	290.5	250	40.5	34	20	20	M12×1.75P
C20-ER20M-100L	140.5	100	40.5	28	20	20	M12×1.75P
C20-ER20M-150L	194.5	150	40.5	28	20	20	M12×1.75P
C20-ER20M-200L	240.5	200	40.5	28	20	20	M12×1.75P
C20-ER20M-250L	290.5	250	40.5	28	20	20	M12×1.75P
C20-ER25UM-100L	151	100	51	42	25	20	M12×1.75P
C20-ER25UM-150L	201	150	51	42	25	20	M12×1.75P
规格 / 型号 Model	L	L1	L2	D	d	C	T
C25-ER20A-100L	140.5	100	40.5	34	20	25	M14×2.0P
C25-ER20A-150L	194.5	150	40.5	34	20	25	M14×2.0P
C25-ER20A-200L	240.5	200	40.5	34	20	25	M14×2.0P
C25-ER20M-100L	140.5	100	40.5	28	20	25	M14×2.0P
C25-ER20M-150L	194.5	150	40.5	28	20	25	M14×2.0P
C25-ER20M-200L	240.5	200	40.5	28	20	25	M14×2.0P
C25-ER25UM-100L	150	100	51	42	25	25	M14×2.0P
C25-ER25UM-150L	201	150	51	42	25	25	M14×2.0P
C25-ER25UM-200L	251	200	51	42	25	25	M14×2.0P
C25-ER25UM-250L	301	250	51	42	25	25	M14×2.0P
C25-ER32UM-100L	151.5	100L	51.5	50	32	25	M14×2.0P
C25-ER32UM-150L	201.5	150L	51.5	50	32	25	M14×2.0P
规格 / 型号 Model	L	L1	L2	D	d	C	T
C32-ER25UM-100L	151.5	100L	51.5	50	25	25	M16×2.0P
C32-ER25UM-150L	201.5	150L	51.5	50	25	25	M16×2.0P
C32-ER25UM-200L	251.5	200L	51.5	50	25	25	M16×2.0P
C32-ER32UM-100L	151.5	100	51.5	50	32	32	M16×2.0P
C32-ER32UM-150L	201.5	150	51.5	50	32	32	M16×2.0P
C32-ER32UM-200L	251.5	200	51.5	50	32	32	M16×2.0P
C32-ER32UM-250L	301.5	250	51.5	50	32	32	M16×2.0P
C32-ER32UM-300L	351.5	300	51.5	50	32	32	M16×2.0P
C32-ER40UM-100L	165	100	65	63	40	32	M16×2.0P
C32-ER40UM-150L	215	150	65	63	40	32	M16×2.0P
C32-ER40UM-200L	265	200	65	63	40	32	M16×2.0P

### 特点:

- ◎ 材质 20CrMnTi/15CrMo, 表面硬度在 52-55HRC, 心部硬度 40-45HRC
- ◎ ER 直柄延长杆, 柄体较长, 适合于深孔加工
- ◎ 延长杆外径与其他部位都经过研磨, 消除不平衡余量, 利于切削的稳定性
- ◎ 可减少对加长刀具的选用, 可降低成本, 提高效率
- ◎ 精度 :0.005mm

### Features:

- ◎ Material:20CrMnTi, Surface hardness:52-55HRC, Shank hardness:40-45HRC.
- ◎ Shank is longer, suitable for deep hole processing.
- ◎ Outer diameter and other parts after grinding, eliminate the unbalanced allowance, conducive to the stability of the cutting.
- ◎ Can reduce to the selection of lengthen cutting tool, reduce cost and improve efficiency.
- ◎ Precision:0.005mm.



## SL-ER - 侧固直柄延长杆

## SL-ER STRAIGHT SHANK COLLET CHUCK AND EXTENSION TYPE

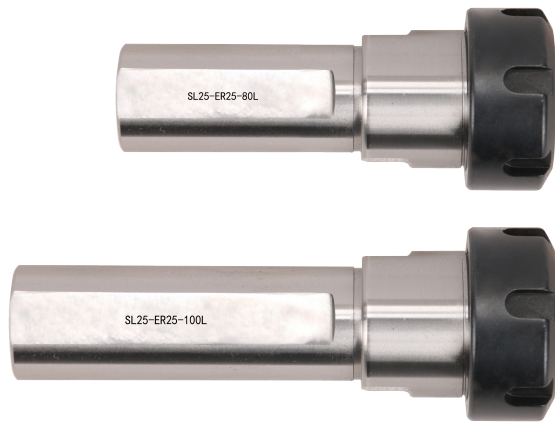

P.131

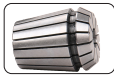

P.106



P.133

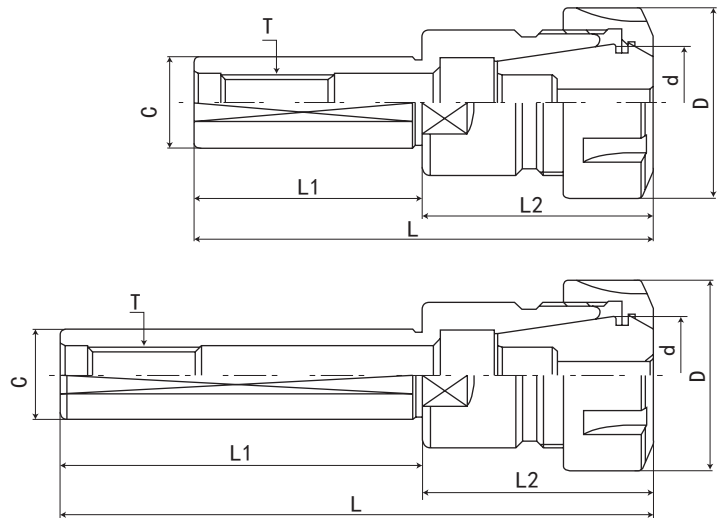

规格 / 型号 Model	L	L1	L2	D	d	C	T
SL16-ER16-80L	122	80	42	28	16	16	M10*1.5P
SL16-ER16-100L	142	100	42	28	16	16	M10*1.5P
SL20-ER16-80L	122	80	42	28	16	20	M12*1.75P
SL20-ER20-80L	122	80	42	34	20	20	M12*1.75P
SL20-ER20-100L	142	100	42	34	20	20	M12*1.75P
SL20-ER25-80L	132	80	52	42	25	20	M12*1.75P
SL20-ER32-80L	132	80	52	50	32	20	M12*1.75P
SL25-ER20-80L	122	80	42	34	20	25	M12*1.75P
SL25-ER25-80L	132	80	52	42	25	25	M12*1.75P
SL25-ER25-100L	152	100	52	42	25	25	M12*1.75P
SL25-ER32-80L	132	80	52	50	32	25	M12*1.75P
SL25-ER40-80L	145	80	65	63	40	25	M12*1.75P
SL32-ER20-80L	122	80	42	34	20	32	M16*2.0P
SL32-ER25-80L	132	80	52	42	25	32	M16*2.1P
SL32-ER32-80L	132	80	52	50	32	32	M16*2.2P
SL32-ER32-100L	152	100	52	50	32	32	M16*2.3P
SL32-ER40-80L	145	80	65	63	40	32	M16*2.4P
SL40-ER25-80L	132	80	52	42	25	40	M16*2.5P
SL40-ER32-80L	132	80	52	50	32	40	M16*2.6P
SL40-ER32-100L	152	100	52	50	32	40	M16*2.7P

### 特点:

- ◎适用于各式 CNC 车床，走心式或是走刀式等自动车床，可作为一个刀夹（夹钻头、立铣刀、小镗刀等），可以通过吸收震动提高效率
- ◎材质：20CrMnTi/15CrMo，表面硬度在 52-55HRC，心部硬度 40-45HRC
- ◎内孔同心度：0.005mm
- ◎夹持柄位有削平端供刀座侧边螺丝锁固

### Features:

- ◎ Applicable to a variety of CNC lathes, Swiss Type, or walk the knife-type automatic lathes, etc. can be used as a knife folder (folder drills, end mills, small boring tool, etc.) can be shock-absorbing efficiency.
- ◎ Material: 20CrMnTi/15CrMo, Hardness: 52-55HRC, shank hardness: 40-45HRC.
- ◎ Hole Concentricity: 0.005mm.
- ◎ Clamping handle bit-side leveling screw for locking the side of a knife block.

# 刀柄配件系列 HOLDER ACCESSORIES

## 直柄两端 ER 铣夹头柄

STRAIGHT SHANK WITH ER MILLING COLLETS AT BOTH SIDES

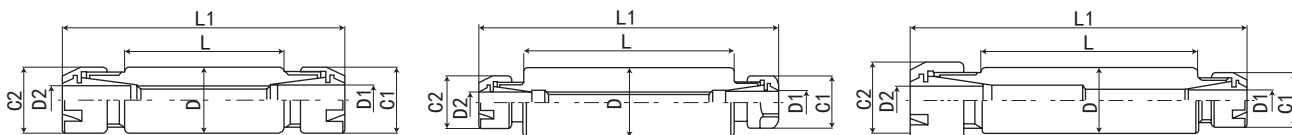

规格 / 型号 Model	Fig	D	L	L1	D1	D2	C1	C2
CD16-ER11M-40	1	16	40	72	1-7	1-7	19	19
CD19.05-ER11M-40	2	19.05	40	72	1-7	1-7	19	19
CD19.05-ER11M-50	2	19.05	50	82	1-7	1-7	19	19
CD19.05-ER11M-60	2	19.05	60	92	1-7	1-7	19	19
CD19.05-ER11M-90	2	19.05	90	122	1-7	1-7	19	19
CD19.05-ER11M-100	2	19.05	100	132	1-7	1-7	19	19
CD20-ER11M-50	2	20	50	82	1-7	1-7	19	19
CD20-ER11M-60	2	20	60	92	1-7	1-7	19	19
CD19.5-ER16M-60	1	19.05	60	112	1-10	1-10	22	22
CD19.5-ER16M-75	1	19.05	75	127	1-10	1-10	22	22
CD20-ER16M-40	1	20	40	92	1-10	1-10	22	22
CD20-ER16M-60	1	20	60	112	1-10	1-10	22	22
CD20-ER16M-75	1	20	75	127	1-10	1-10	22	22
CD20-ER16M-100	1	20	100	152	1-10	1-10	22	22
CD22-ER16M-60	1	22	60	112	1-10	1-10	22	22
CD22-ER16M-75	1	22	75	127	1-10	1-10	22	22
CD22-ER16M-90	1	22	90	142	1-10	1-10	22	22
CD22-ER16M-100	1	22	100	152	1-10	1-10	22	22
CD25-ER16M-50	2	25	50	102	1-10	1-10	22	22
CD25-ER16M-60	2	25	60	112	1-10	1-10	22	22
CD25-ER16M-70	2	25	70	122	1-10	1-10	22	22
CD25-ER16M-50	2	25	50	102	1-10	1-10	22	22
CD25.4-ER16M-60	2	25.4	60	112	1-10	1-10	22	22
CD25.4-ER16M-70	2	19.05	70	122	1-10	1-10	22	22
CD25.4-ER16M-75	2	19.05	75	127	1-10	1-10	22	22
CD25-ER20M-80	1	25	80	134	1-13	1-13	28	28
CD25.4-ER20M-80	1	25.4	80	134	1-13	1-13	28	28
CD32-ER20M-60	2	32	60	114	1-13	1-13	28	28
CD32-ER20M-80	2	32	80	134	1-13	1-13	28	28
CD19.05-ER11M/ER16M-50	3	19.05	50	92	1-7	1-10	16	22
CD20-ER11M/ER16M-50	3	20	50	92	1-7	1-10	16	22
CD19.05-ER11M/ER20M-50	3	19.05	50	120	1-7	1-13	16	28
CD20-ER11M/ER20M-50	3	20	50	120	1-7	1-13	16	28
CD22-ER16M/ER20M-45	3	22	45	98	1-10	1-13	22	28
CD22-ER16M/ER20M-60L	3	22	60	113	1-10	1-13	22	28
CD22-ER16M/ER20M-45L	3	25	45	98	1-10	1-13	22	28
CD25-ER16M/ER20M-60L	3	25	60	113	1-10	1-13	22	28
CD25-ER16M/ER25M-45L	3	25	45	115	1-10	1-16	22	35
CD25-ER16M/ER25M-60L	3	25	60	130	1-10	1-16	22	35
CD25-ER16M/ER25M-61L	3	32	80	131	1-13	1-16	28	35

### 特点:

- ◎材质: 20CrMnTi/15CrMo
- ◎表面硬度: 52-55HRC
- ◎心部硬度: 40-45HRC
- ◎精度: 0.005mm

### Features:

- ◎ Material:20CrMnTi
- ◎ Surface Hardness:52-55HRC
- ◎ Shank Hardness:40-45HRC
- ◎ Accuracy:0.005mm

## 内锥 ER 系列钻铣夹头

## DRILL AND MILLING CHUCK-ER

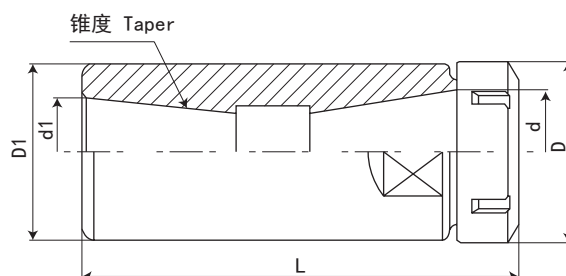

P.131



P.106



P.133

规格 / 型号 Model	L	D	D1	d	d1	锥度 Taper
B10-ER11	55	19	19	11	10.094	B10
B10-ER16	60	28	22	16	10.094	B10
B12-ER16	60	28	22	16	12.065	B12
B12-ER20	60	34	27	20	12.065	B12
B16-ER16	70	28	22	16	15.733	B16
B16-ER20	70	34	27	20	15.733	B16
B16-ER25	85	42	27	25	15.733	B16
B16-ER32	80	50	40	32	15.733	B16
B18-ER16	70	28	22	16	17.780	B18
B18-ER20	80	34	27	20	17.780	B18
B18-ER25	85	42	32	25	17.780	B18
B18-ER32	80	50	40	32	17.780	B18
B22-ER25	80	42	32	25	21.793	B22
B22-ER32	80	50	40	32	21.793	B22
JT0-ER11	52	19	19	11	6.35	JT0
JT1-ER11	58	19	19	11	9.754	JT1
JT1-ER16	67	28	22	16	9.754	JT1
JT2-ER16	72	28	22	16	14.199	JT2
JT6-ER16	75	28	22	16	17.170	JT6
JT6-ER20	81	34	27	20	17.170	JT6
JT6-ER25	85	42	32	25	17.170	JT6
JT6-ER32	85	50	40	32	17.170	JT6
JT3-ER20	105	34	27	20	20.599	JT3

HOLDER  
ACCESSORIES  
刀柄配件

## 直孔 ER 系列钻铣夹头

## DRILL AND MILLING CHUCK-ER

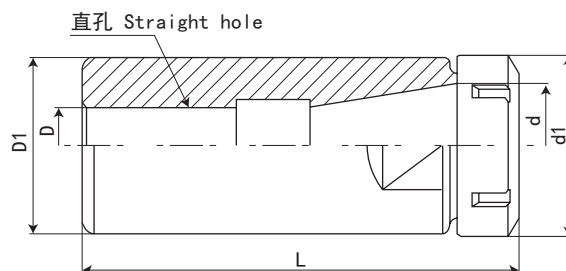

P.131



P.106



P.133

规格 / 型号 Model	L	D	D1	d	d1
D5-ER11	55	5	19	11	19
D6-ER11	55	6	19	11	19
D8-ER11	55	8	19	11	19
D5-ER16	65	5	22	16	28
D6-ER16	65	6	22	16	28
D8-ER16	65	8	22	16	28
D10-ER16	65	10	22	16	28

# 刀柄配件系列 HOLDER ACCESSORIES

## 内螺孔 ER 系列钻铣夹头

DRILL AND MILLING CHUCK-ER

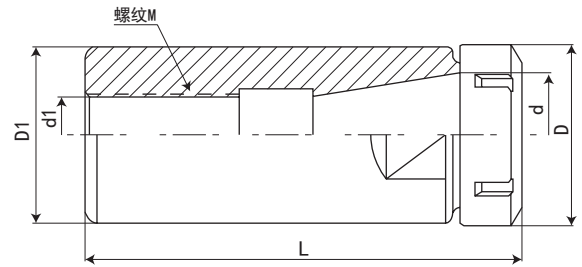

	d1	L	d	D1	D
M-ER16-50L	M1/2-20UNF	50	16	30	28
	M3/4-16UNF	50	16	30	28
	M12*1	50	16	30	28
	M14*1	50	16	30	28

## ER 直孔夹头座

ER COLLET FIXTURE

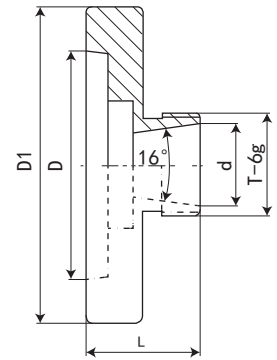
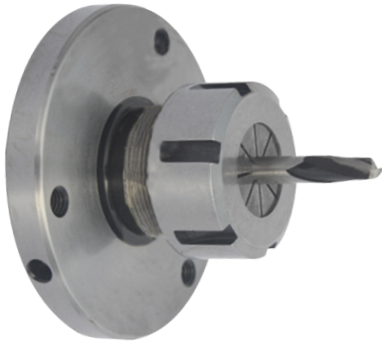

规格 / 型号 Model	D	D1	d	T	L	所配夹头 Collet
ER16-D140	22	45	16	M22*1.5P	25	ER16
ER25-D210	72	100	25	M32*1.5P	36	ER25
ER25-D250	52	102	25	M32*1.5P	36	ER25
ER25-102	52	102	25	M32*1.5P	40	ER25
ER25-BZ300	100	132	25	M32*1.5P	34	ER25
ER32-55	55	80	32	M40*1.5P	42	ER32
ER32-72	72	100	32	M40*1.5P	42	ER32
ER32-95	95	125	32	M40*1.5P	42	ER32
ER32-100	100	132	32	M40*1.5P	42	ER32
ER32-130	130	160	32	M40*1.5P	42	ER32
ER32-132	132	163	32	M40*1.5P	42	ER32

## ER 锥孔夹头座

ER COLLET FIXTURE

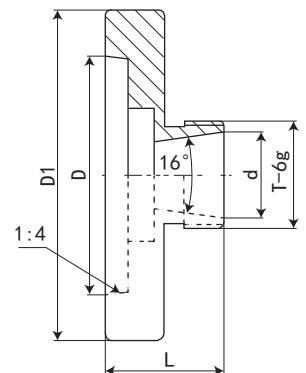
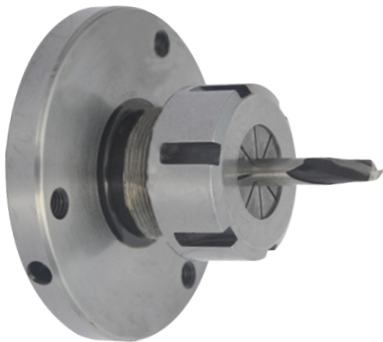

规格 / 型号 Model	D	D1	d	T	L	所配夹头 Collet
ER25-D250Z	53.975	102	25	M32*1.5P	40	ER25

# 侧固式 SLD 小径延长杆

## SLD STRAIGHT EXTENSION SIDE LOCK HOLDER

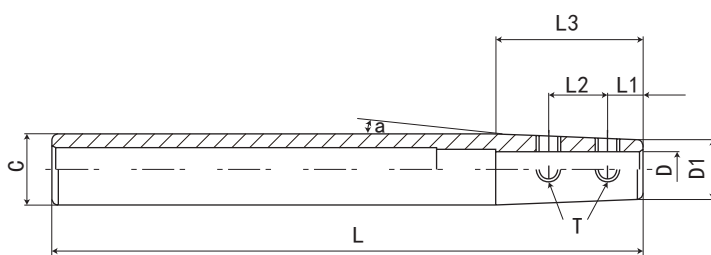

规格 / 型号 Model	L	L1	L2	L3	C	D	D1	a	T
C8-SLD3-100L-直柄	100	10	12	/	8	3	8	-	M3.5*0.35P
C8-SLD3.175-100L-直柄	100	10	12	/	8	3.175	8	-	M3.5*0.35P
C8-SLD3-130L-A2.0	130	10	12	45	8	3	7	2.0	M3.5*0.35P
C10-SLD3-100L-直柄	100	10	12	/	10	3	10	-	M3.5*0.35P
C10-SLD3.175-100L-直柄	100	10	12	/	10	3.175	10	-	M3.5*0.35P
C10-SLD4-100L-直柄	100	10	12	/	10	4	10	-	M4*0.5P
C12-SLD3-100L-A2.5	100	10	12	25	12	3	9	2.5	M3.5*0.35P
C12-SLD3-120L-A2.5	120	10	12	25	12	3	9	2.5	M3.5*0.35P
C12-SLD3-150L-A2.5	150	10	12	25	12	3	9	2.5	M3.5*0.35P
C12-SLD4-100L-A2.5	100	10	12	25	12	4	10	2.5	M4*0.5P
C12-SLD4-120L-A2.0	120	10	12	30	12	4	10	2.0	M4*0.5P
C12-SLD4-150L-A2.0	150	10	12	30	12	4	10	2.0	M4*0.5P
C12-SLD6-120L-A2.0	120	10	12	30	12	6	12	2.0	M5*0.5P
C12-SLD6-150L-A2.0	150	10	12	30	12	6	12	2.0	M5*0.5P
C16-SLD3-120LA2.5	120	10	12	70	16	3	9	2.5	M3.5*0.35P
C16-SLD3-150L-A2.0	150	10	12	90	16	3	9	2.0	M3.5*0.35P
C16-SLD4-120L-A2.5	120	10	12	50	16	4	10	2.5	M4*0.5P
C16-SLD4-150L-A2.5	150	10	12	70	16	4	10	2.5	M4*0.5P
C16-SLD4-200L-A2.0	200	10	12	90	16	4	10	2.0	M4*0.5P
C16-SLD6-120L-A1.5	120	10	12	50	16	6	12	1.5	M5*0.5P
C16-SLD6-150L-A1.5	150	10	12	70	16	6	12	1.5	M5*0.5P
C16-SLD6-200L-A1.5	200	10	12	90	16	6	12	1.5	M5*0.5P
C16-SLD8-120L-A1.5	120	10	15	35	16	8	14	1.5	M5*0.5P
C16-SLD8-150L-A1.5	150	10	15	35	16	8	14	1.5	M5*0.5P
C16-SLD8-150L-A1.0	150	10	15	60	16	8	14	1.0	M5*0.5P
C20-SLD3-120L-A2.0	120	10	12	45	20	3	9	2.0	M3.5*0.35P
C20-SLD3-150L-A2.0	150	10	12	45	20	3	9	2.0	M3.5*0.35P
C20-SLD4-120L-A2.0	120	10	12	30	20	4	10	2.0	M4*0.5P
C20-SLD4-150L-A2.0	150	10	12	30	20	4	10	2.0	M4*0.5P
C20-SLD6-120L-A1.5	120	10	12	50	20	6	12	1.5	M5*0.5P
C20-SLD6-150L-A1.5	150	10	12	70	20	6	12	1.5	M5*0.5P
C20-SLD6-200L-A1.5	200	10	12	90	20	6	12	1.5	M5*0.5P
C20-SLD8-120L-A1.5	120	10	15	35	20	8	14	1.5	M5*0.5P
C20-SLD8-150L-A1.0	150	10	15	70	20	8	18	1.0	M5*0.5P
C20-SLD8-200L-A1.0	200	10	15	70	20	8	18	1.0	M5*0.5P
C20-SLD10-120L-A1.5	120	10	16	35	20	10	18	1.5	M5*0.5P
C20-SLD10-150L-A1.5	150	10	16	35	20	10	18	1.5	M5*0.5P
C20-SLD10-200L-A1.5	200	10	16	45	20	10	18	1.5	M5*0.5P
C20-SLD12-120L-A1.0	120	12	18	35	20	12	19	1.0	M6*0.75P
C20-SLD12-150L-A1.0	150	12	18	35	20	12	19	1.0	M6*0.75P
C20-SLD12-200L-A1.0	200	12	18	35	20	12	19	1.0	M6*0.75P
C25-SLD10-250L-A2.0	200	10	16	80	25	10	20	2.0	M5*0.5P
C25-SLD10-250L-A2.0	250	10	16	110	25	10	18	2.0	M5*0.5P
C25-SLD12-200L-A2.0	200	12	18	80	25	12	19	2.0	M6*0.75P
C25-SLD12-250L-A1.5	250	12	18	110	25	12	19	1.5	M6*0.75P

HOLDER  
ACCESSORIES  
刀柄配件

# 刀柄配件系列 HOLDER ACCESSORIES

## MTA-ER 扁尾式莫氏刀柄

## MTA-ER COLLET CHUCK

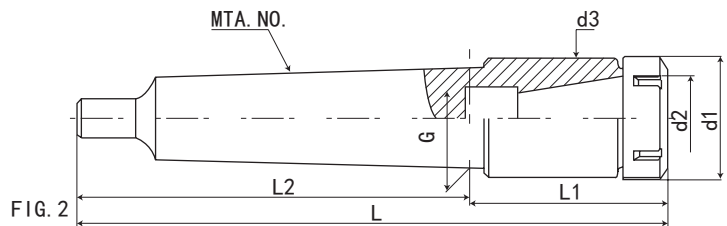
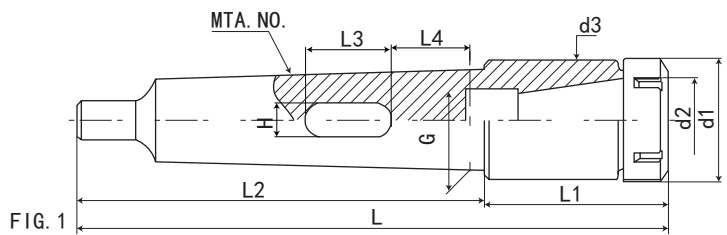

P.131



P.106



P.133

规格 / 型号 Model	L	L1	L2	L3	L4	d1	d2	H	G	Fig	夹持范围 Range
MTA1-ER16-60L	129	60	69	-	-	28	16	-	12.065	2	1-10
MTA2-ER16-60L	144	60	84	-	-	28	16	-	17.780	2	1-10
MTA2-ER20-50L	134	50	84	-	-	34	20	-	17.780	2	1-13
MTA2-ER25-55L	139	55	84	-	-	42	25	-	17.780	2	1-16
MTA2-ER32-65L	149	65	84	-	-	50	32	-	17.780	2	1-20
MTA2-ER40-70L	154	70	84	-	-	63	40	-	17.780	2	2-26
MTA3-ER16-40L	139	40	99	-	-	28	16	-	23.825	2	1-10
MTA3-ER20-50L	149	50	99	-	-	34	20	-	23.825	2	1-13
MTA3-ER25-55L	154	55	99	-	-	42	25	-	23.825	2	1-16
MTA3-ER32-70L	169	70	99	-	-	50	32	-	23.825	2	1-20
MTA3-ER40-70L	169	70	99	-	-	63	40	-	23.825	2	2-26
MTA4-ER20-40L	164	40	124	-	-	34	20	-	31.267	2	1-13
MTA4-ER25-40L	164	40	124	-	-	42	25	-	31.267	2	1-16
MTA4-ER32-70L	194	70	124	-	-	50	32	-	31.267	2	1-20
MTA4-ER40-70L	194	70	124	-	-	63	40	-	31.267	2	2-26
MTA5-ER32-70L	226	70	156	40	35	50	32	13	44.399	11	1-20
MTA5-ER40-70L	226	70	156	40	35	63	40	13	44.399	1	2-26
MTA5-ER50-80L	236	80	156	40	35	78	50	13	44.399	1	6-36
MTA6-ER32-70L	288	70	218	40	45	50	32	17	63.348	1	1-20
MTA6-ER40-70L	288	70	218	40	45	63	40	17	63.348	1	2-26
MTA6-ER50-100L	318	100	218	40	45	78	50	17	63.348	1	6-36
公制 80-ER40-70L	298	70	228	45	55	63	40	20	80.00	1	2-26
公制 80-ER50-75L	328	100	228	45	55	78	50	20	80.00	1	6-36

## MTB-ER 后拉式莫氏刀柄

## MTB-ER COLLET CHUCK

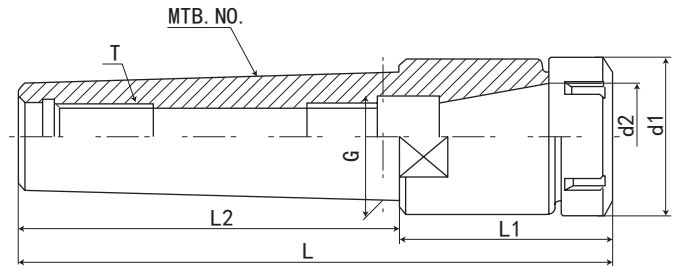

P.131



P.106



P.133

MTB.NO	规格 / 型号 Model	L	L1	L2	d1	d2	T	G	夹持范围 Range
MTB1	MTB1-ER16-40L	96	40	56	28	16	M6*1.0P	12.065	2-10
MTB2	MTB2-ER16-40L	108	40	68	28	16	M10*1.5P	17.780	2-10
	MTB2-ER20-50L	118	50	68	34	20	M10*1.5P	17.780	2-13
	MTB2-ER25-55L	123	55	68	42	25	M10*1.5P	17.780	2-16
	MTB2-ER32-65L	133	65	68	50	32	M10*1.5P	17.780	2-20
	MTB2-ER40-70L	138	70	68	63	40	M10*1.5P	17.780	2-26
MTB3	MTB3-ER16-40L	125	40	85	28	16	M12*1.75P	23.825	2-10
	MTB3-ER20-50L	135	50	85	34	20	M12*1.75P	23.825	2-13
	MTB3-ER25-55L	140	55	85	42	25	M12*1.75P	23.825	2-16
	MTB3-ER32-70L	155	70	85	50	32	M12*1.75P	23.825	2-20
MTB4	MTB4-ER16-40L	148	40	108	28	16	M16*2.0P	31.267	2-10
	MTB4-ER20-40L	148	40	108	34	20	M16*2.0P	31.267	2-13
	MTB4-ER25-40L	148	40	108	42	25	M16*2.0P	31.267	2-16
	MTB4-ER32-70L	178	70	108	50	32	M16*2.0P	31.267	2-20
	MTB4-ER40-70L	178	70	108	63	40	M16*2.0P	31.267	2-26
MTB5	MTB5-ER32-70L	206	70	136	50	32	M20*2.5P	44.399	2-20
	MTB5-ER40-70L	206	70	136	63	40	M20*2.5P	44.399	2-26

HOLDER  
ACCESSORIES  
刀柄配件

## 直柄 C-FMB 铣刀柄

## STRAIGHT SHANK C-FMB SHELL END MILL ARBORS

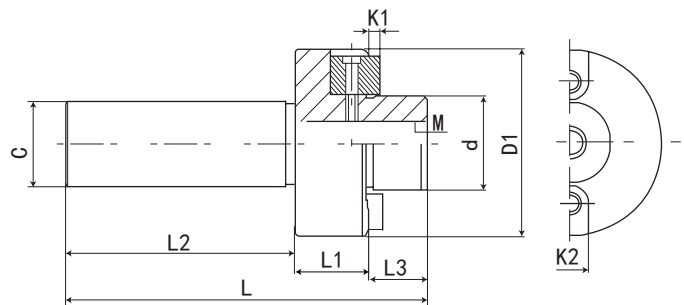

P.L02

规格 / 型号 Model	L	L1	L2	L3	C	D1	d	M	K1	K2
C20-FMB22-L	98	20	60	18	20	48	22	M10*1.5P	4.8	10
C20-FMB27-L	110	20	70	20	20	53	27	M12*1.75P	5.8	12
C25-FMB22-L	108	20	70	18	25	48	22	M10*1.5P	4.8	10
C25-FMB27-L	110	20	70	20	25	53	27	M12*1.75P	5.8	12
C32-FMB22-L	108	20	70	18	32	48	22	M10*1.5P	4.8	10
C32-FMB27-L	110	20	70	20	32	53	27	M12*1.75P	5.8	12

# 刀柄配件系列 HOLDER ACCESSORIES

## MTA-FMB 扁尾式莫氏铣刀柄

## MTA-FMB MORSE TAPER SHELL END MILL ARBORS

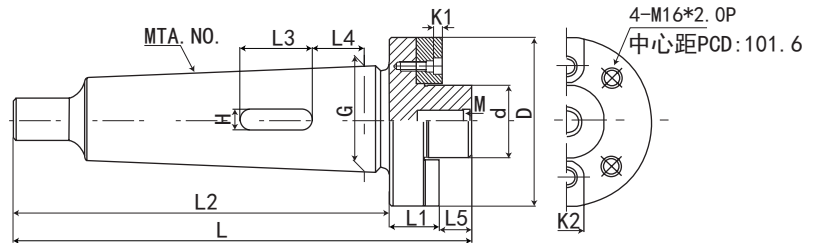
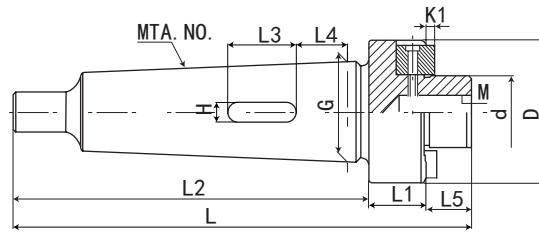

P.L02

MTA.NO	规格 / 型号 Model	L	L1	L2	L3	L4	L5	H	G	D	M	d	k1	k2
MTA4	MTA4-FMB22-25L	167	25	124	-	-	18	-	31.267	47	M10*1.5P	22	4.8	10
	MTA4-FMB27-25L	169	25	124	-	-	20	-	31.267	58	M12*1.75P	27	5.8	12
MTA5	MTA5-FMB22-25L	199	25	156	40	35	18	13	44.399	47	M10*1.5P	22	4.8	10
	MTA5-FMB27-25L	201	25	156	40	35	20	13	44.399	58	M12*1.75P	27	5.8	12
	MTA5-FMB32-25L	203	25	156	40	35	22	13	44.399	64	M16*2.0P	32	6.8	14
	MTA5-FMB40-25L	206	25	156	40	35	25	13	44.399	73	M16*2.0P	40	8.3	16
	MTA5-FMB60-25L	206	25	156	40	35	25	13	44.399	128	M16*2.0P	60	12.5	25.4
MTA6	MTA6-FMB22-25L	261	25	218	40	45	18	17	63.348	48	M10*1.5P	22	4.8	10
	MTA6-FMB27-25L	263	25	218	40	45	20	17	63.348	58	M12*1.75P	27	5.8	12
	MTA6-FMB32-25L	265	25	218	40	45	22	17	63.348	64	M16*2.0P	32	6.8	14
	MTA6-FMB40-25L	268	25	218	40	45	25	17	63.348	73	M16*2.0P	40	8.3	16
	MTA6-FMB60-25L	268	25	218	40	45	25	17	63.348	128	M16*2.0P	60	12.5	25.4
公制 80	公制 80-FMB22-25L	271	25	228	45	55	18	20	80.00	48	M10*1.5P	22	4.8	10
	公制 80-FMB27-25L	273	25	228	45	55	20	20	80.00	58	M12*1.75P	27	5.8	12
	公制 80-FMB32-25L	275	25	228	45	55	22	20	80.00	64	M16*2.0P	32	6.8	14
	公制 80-FMB40-25L	278	25	228	45	55	25	20	80.00	73	M16*2.0P	40	8.3	16
	公制 80-FMB60-25L	278	25	228	45	55	25	20	80.00	128	M16*2.0P	60	12.5	25.4

## MTB-FMB 后拉式莫氏铣刀柄

## MTB-FMB MORSE TAPER SHELL END MILL ARBORS

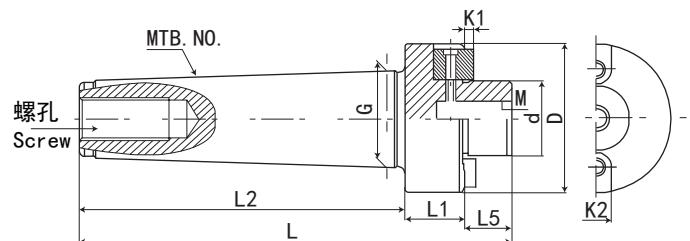

P.L02

MTB.NO	规格 / 型号 Model	L	L1	L2	L5	螺孔	G	D	M	d	k1	K2 键宽
MTB3	MTB3-FMB22-25L	128	25	85	18	M12×1.75P	23.825	47	M10*1.5P	22	4.8	10
	MTB3-FMB27-25L	130	25	85	20	M12×1.75P	23.825	58	M12*1.75P	27	5.8	12
MTB4	MTB4-FMB22-25L	151	25	108	18	M16×2.0P	31.267	47	M10*1.5P	22	4.8	10
	MTB4-FMB27-25L	153	25	108	20	M16×2.0P	31.267	58	M12*1.75P	27	5.8	12
	MTB4-FMB32-25L	155	25	108	22	M16×2.0P	31.267	64	M16*2.0P	32	6.8	14
	MTB4-FMB40-25L	158	25	108	25	M16×2.0P	31.267	73	M16*2.0P	40	8.3	16



## MTA-C 型莫氏强力刀柄

## MTA-C MOSER TAPER SHANK MILLING CHUCK

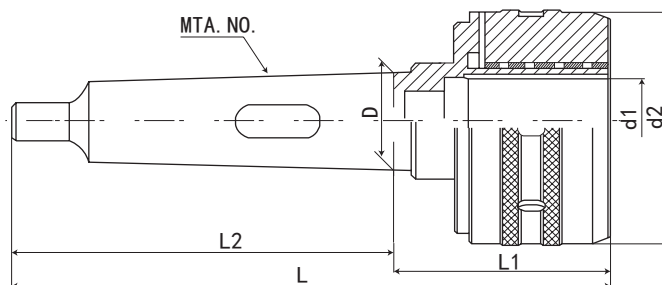

P.130

P.116

规格 / 型号 Model	MTA.NO	L	L1	L2	D	d1	d2	夹持范围 Range
MTA3-C25-95L	MTA3	194	95	99	23.825	25	58	3 4 5 6 8 10 12 14 16 18 20
MTA3-C32-95L	MTA3	194	95	99	23.825	32	74	3 4 5 6 8 10 12 14 16 18 20 22 24 25
MTA4-C25-95L	MTA4	219	95	124	31.267	25	58	3 4 5 6 8 10 12 14 16 18 20
MTA4-C32-95L	MTA4	219	95	124	31.267	32	74	3 4 5 6 8 10 12 14 16 18 20 22 24 25
MTA5-C32-95L	MTA5	251	95	156	44.395	32	74	3 4 5 6 8 10 12 14 16 18 20 22 24 25
MTA6-C32-95L	MTA6	313	95	218	63.348	32	74	3 4 5 6 8 10 12 14 16 18 20 22 24 25
公制 80-C32-95L	公制 80	323	95	228	80.00	32	74	3 4 5 6 8 10 12 14 16 18 20 22 24 25

## MTB-C 型莫氏强力刀柄

## MTB-C MOSER TAPER SHANK MILLING CHUCK

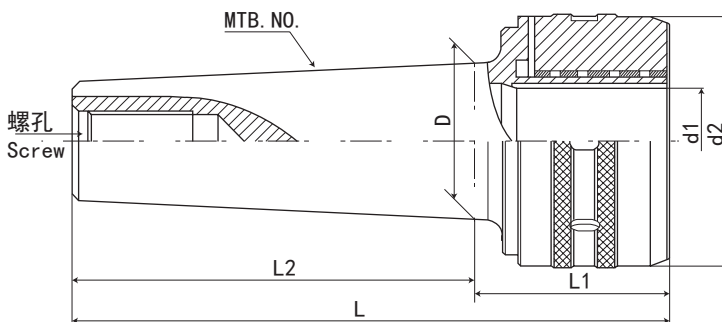

P.130

P.116

规格 / 型号 Model	MTB.NO	L	L1	L2	D	d1	d2	夹持范围 Range	连接螺纹
MTB3-C25-90L	MTB3	175	90	85	23.825	25	58	3 4 5 6 8 10 12 14 16 18 20	M12×1.75P, 后拉式
MTB3-C32-90L	MTB3	175	90	85	23.825	32	68	3 4 5 6 8 10 12 14 16 18 20 22 24 25	M12×1.75P, 后拉式
MTB4-C25-90L	MTB4	198	90	108	31.267	25	58	3 4 5 6 8 10 12 14 16 18 20	M14×2.0P, 后拉式
MTB4-C32-95L	MTB4	203	95	108	31.267	32	68	3 4 5 6 8 10 12 14 16 18 20 22 24 25	M14×2.0P, 后拉式
MTB5-C32-95L	MTB5	231	95	136	44.395	32	68	3 4 5 6 8 10 12 14 16 18 20 22 24 25	M20×2.5P, 后拉式

## R8-C 型强力刀柄

## R8-C SHANK MILLING CHUCK

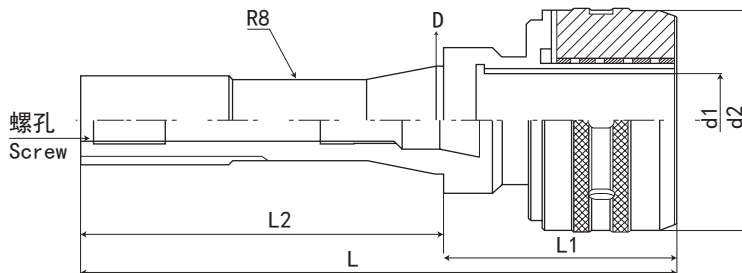

P.130

P.116

规格 / 型号 Model	L	L1	L2	D	d1	d2	夹持范围 Range	螺孔 Screw
R8-C25-70L	172	70	102	32	25	58	3 4 5 6 8 10 12 14 16 18 20	M12*1.75P-7/16
R8-C32-75L	175	75	102	32	32	68	3 4 5 6 8 10 12 14 16 18 20 22 24 25	M12*1.75P-7/16

# 刀柄配件系列 HOLDER ACCESSORIES

## MTA-LBK 扁尾式莫氏镗头刀柄

## MORSE TAPER BORING HEAD SHANK

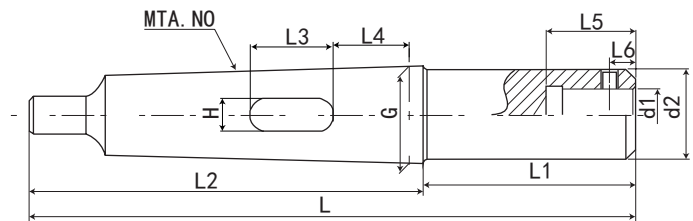

FIG. 1

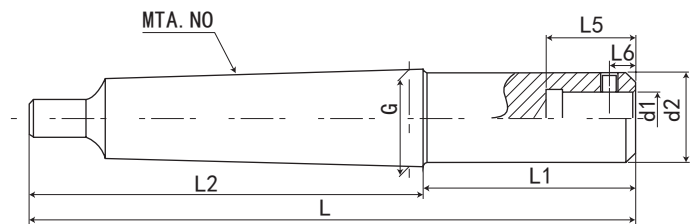

FIG. 2



P.J39

MTA.NO	规格 / 型号 Model	G	L	L1	L2	L3	L4	L5	L6	d1	d2	侧边螺丝 Screw	H	FIG
MTA3	MTA3-LBK1-70L	23.825	169	70	99	-	-	30	5.05	11	19	M4*0.5P	-	2
	MTA3-LBK2-100L	23.825	199	100	99	-	-	31	6.62	14	24	M5*0.5P	-	2
	MTA3-LBK3-100L	23.825	199	100	99	-	-	35	8	18	31	M6*0.75P	-	2
	MTA3-LBK4-100L	23.825	199	100	99	-	-	39	10	22	39	M8*0.75P	-	2
	MTA3-LBK5-100L	23.825	199	100	99	-	-	45	13	28	50	M10*1.0P	-	2
	MTA3-LBK6-100L	23.825	199	100	99	-	-	55	16	36	63	M12*1.0P	-	2
MTA4	MTA4-LBK1-70L	31.267	194	70	124	-	-	30	5.05	11	19	M4*0.5P	-	2
	MTA4-LBK2-100L	31.267	224	100	124	-	-	31	6.62	14	24	M5*0.5P	-	2
	MTA4-LBK3-100L	31.267	224	100	124	-	-	35	8	18	31	M6*0.75P	-	2
	MTA4-LBK4-100L	31.267	224	100	124	-	-	39	10	22	39	M8*0.75P	-	2
	MTA4-LBK5-100L	31.267	224	100	124	-	-	45	13	28	50	M10*1.0P	-	2
	MTA4-LBK6-100L	31.267	224	100	124	-	-	55	16	36	63	M12*1.0P	-	2
MTA5	MTA5-LBK2-100L	44.399	256	100	156	40	35	31	6.62	14	24	M5*0.5P	13	1
	MTA5-LBK3-125L	44.399	281	125	156	40	35	35	8	18	31	M6*0.75P	13	1
	MTA5-LBK4-125L	44.399	281	125	156	40	35	39	10	22	39	M8*0.75P	13	1
	MTA5-LBK5-125L	44.399	281	125	156	40	35	45	13	28	50	M10*1.0P	13	1
	MTA5-LBK6-125L	44.399	281	125	156	40	35	55	16	36	63	M12*1.0P	13	1
MTA6	MTA6-LBK4-125L	63.348	343	125	218	40	45	39	10	22	39	M8*0.75P	17	1
	MTA6-LBK5-125L	63.348	343	125	218	40	45	45	13	28	50	M10*1.0P	17	1
	MTA6-LBK6-125L	63.348	343	125	218	40	45	55	16	36	63	M12*1.0P	17	1
公制 80	公制 80-LBK6-150L	80.00	378	150	228	45	55	55	16	36	63	M12*1.0P	20	1

## MTB-SCA 莫氏后拉式侧铣刀杆

## MTB-SCA MORSE TAPER SIDE CUTTER ADAPTET

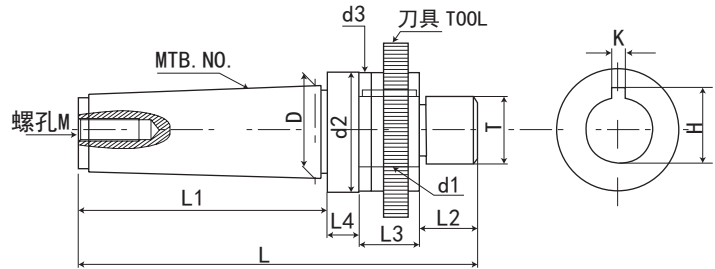

莫氏型号 Morse	规格 / 型号 Model	L	L1	L2	L3	L4	D	d1	d2	d3	K	H	T	M
MTB3	MTB3-SCA13-35L	167	86	16	30	35	23.825	13	26	26	/	/	M12*1.5P	M12*1.75P
	MTB3-SCA16-35L	167	86	16	30	35	23.825	16	26	26	4	17.7	M14*1.5P	M12*1.75P
	MTB3-SCA22-35L	173	86	22	30	35	23.825	22	34	34	6	24.3	M20*1.5P	M12*1.75P
	MTB3-SCA25.4-35L	179	86	28	30	35	23.825	25.4	40	40	6.35	28.4	M24*1.5P	M12*1.75P
	MTB3-SCA27-35L	179	86	28	30	35	23.825	27	40	40	7	30	M24*1.5P	M12*1.75P
	MTB3-SCA31.75-35L	183	86	32	30	35	23.825	31.75	47	47	7.93	34.8	M30*1.5P	M12*1.75P
	MTB3-SCA32-35L	183	86	32	30	35	23.825	32	47	47	8	35	M30*1.5P	M12*1.75P
MTB4	MTB4-SCA13-45L	200	109	16	30	45	31.267	13	26	26	/	/	M12*1.5P	M14*2.0P/M16*2.0P
	MTB4-SCA16-45L	200	109	16	30	45	31.267	16	26	26	4	17.7	M14*1.5P	M14*2.0P/M16*2.0P
	MTB4-SCA22-45L	206	109	22	30	45	31.267	22	34	34	6	24.3	M20*1.5P	M14*2.0P/M16*2.0P
	MTB4-SCA25.4-45L	212	109	28	30	45	31.267	25.4	40	40	6.35	28.4	M24*1.5P	M14*2.0P/M16*2.0P
	MTB4-SCA27-45L	212	109	28	30	45	31.267	27	40	40	7	30	M24*1.5P	M14*2.0P/M16*2.0P
	MTB4-SCA31.75-45L	216	109	32	30	45	31.267	31.75	47	47	7.93	34.8	M30*1.5P	M14*2.0P/M16*2.0P
	MTB4-SCA32-45L	216	109	32	30	45	31.267	32	47	47	8	35	M30*1.5P	M14*2.0P/M16*2.0P

## 直柄 C-SCA 侧铣刀杆

## STRAIGHT SHANK C-SCA CUTTER ADAPTET

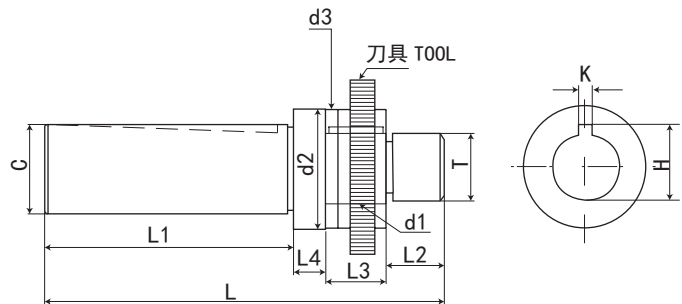

规格 / 型号 Model	L	L1	L2	L3	L4	d1	d2	d3	K	H	T
C6-SCA5	60	30	8	12	10	5	11	11	/	/	M4*0.7P
C7-SCA6	60	30	8	12	10	6	12	12	/	/	M5*0.8P
C10-SCA6	80	50	8	12	10	5	12	12	/	/	M5*0.8P
C10-SCA8	80	50	8	12	10	8	14	14	/	/	M6*1.0P
C10-SCA10	100	50	10	30	10	10	18	18	/	/	M8*1.25P
C10-SCA13	104	50	10	30	14	13	26	26	/	/	M12*1.5P
C10-SCA16	104	50	10	30	14	16	26	26	/	/	M14*1.5P
C13-SCA13	104	50	10	30	14	13	26	26	/	/	M12*1.5P
C13-SCA16	104	50	10	30	14	16	26	26	/	/	M14*1.5P
C16-SCA13	112	50	16	30	16	13	26	26	/	/	M12*1.5P
C16-SCA16	116	50	16	30	20	16	26	26	4	17.7	M14*1.5P
C16-SCA22	122	50	22	30	20	22	34	34	6	24.3	M20*1.5P
C20-SCA16	126	60	16	30	20	16	26	26	4	17.7	M14*1.5P
C20-SCA22	132	60	22	30	20	22	34	34	6	24.3	M20*1.5P
C20-SCA27	143	60	28	30	25	27	40	40	7	30	M24*1.5P
C25-SCA22	142	65	22	30	25	22	34	34	6	24.3	M20*1.5P
C25-SCA27	148	65	28	30	25	27	40	40	7	30	M24*1.5P
C25-SCA32	157	65	32	30	30	32	47	47	8	35	M30*1.5P
C32-SCA22	147	70	22	30	25	22	34	34	6	24.3	M20*1.5P
C32-SCA27	158	70	28	30	30	27	40	40	7	30	M24*1.5P
C32-SCA32	162	70	32	30	30	32	47	47	8	35	M30*1.5P
C40-SCA32	177	85	32	30	30	32	47	47	8	35	M30*1.5P
C40-SCA40	191	86	40	30	35	40	55	55	10	43.7	M36*2.0P

# 刀柄配件系列 HOLDER ACCESSORIES

## MTA-SLN 莫氏扁尾式侧固刀柄

## MTA-SLN MORSE TAPER SIDE LOCK END MILL HOLDER

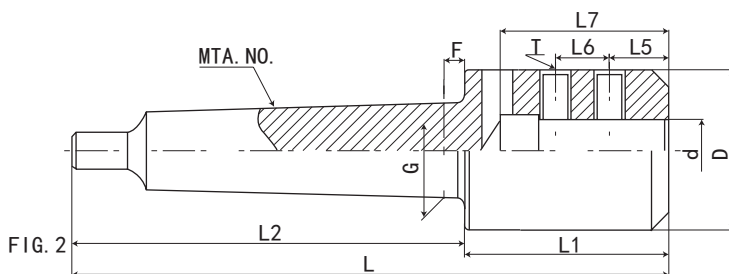
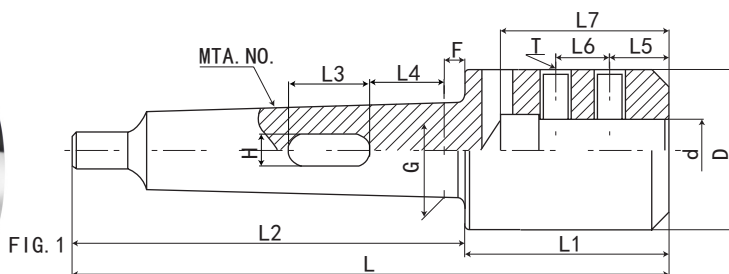

莫氏型号 Morse	规格 / 型号 Model	L	L1	L2	L3	L4	L5	L6	L7	D	d	G	F	T	FIG
MTA3	MTA3-SLN20-80L	179	80	99	/	/	25	20	70	53	20	23.825	5	M12*1.75P	2
	MTA3-SLN25-95L	194	95	99	/	/	24	25	80	53	25	23.825	5	M12*1.75P	2
	MTA3-SLN32-95L	194	95	99	/	/	24	28	85	53	32	23.825	5	M16*2.0P	2
MTA4	MTA4-SLN20-65L	189	65	124	/	/	25	20	70	53	20	31.267	6.5	M12*1.75P	2
	MTA4-SLN25-95L	219	95	124	/	/	24	25	80	53	25	31.267	6.5	M12*1.75P	2
	MTA4-SLN32-95L	219	95	124	/	/	24	28	85	53	32	31.267	6.5	M16*2.0P	2
	MTA4-SLN40-115L	239	115	124	/	/	30	32	100	68	40	31.267	6.5	M20*2.5P	2
MTA5	MTA5-SLN20-65L	221	65	156	40	35	25	20	70	53	20	44.399	6.5	M12*1.75P	1
	MTA5-SLN25-65L	221	65	156	40	35	24	25	80	53	25	44.399	6.5	M12*1.75P	1
	MTA5-SLN32-70L	226	70	156	40	35	24	28	85	53	32	44.399	6.5	M16*2.0P	1
MTA6	MTA6-SLN25-65L	283	65	218	40	45	24	25	80	60	25	63.348	8	M12*1.75P	1
	MTA6-SLN32-70L	288	70	218	40	45	24	28	85	60	32	63.348	8	M16*2.0P	1
	MTA6-SLN40-80L	298	80	218	40	45	30	32	100	68	40	63.348	8	M20*2.5P	1
公制 80	公制 80-SLN32-70L	298	70	228	45	55	24	28	85	65	32	80.00	8	M16*2.0P	1
	公制 80-SLN40-80L	308	80	228	45	55	30	32	100	83	40	80.00	8	M20*2.5P	1
	公制 80-SLN50-85L	313	85	228	45	55	35	35	105	83	50	80.00	8	M20*2.5P	1

## R8-SLN 侧固刀柄

## R8-SLN SIDE LOCK END MILL HOLDER

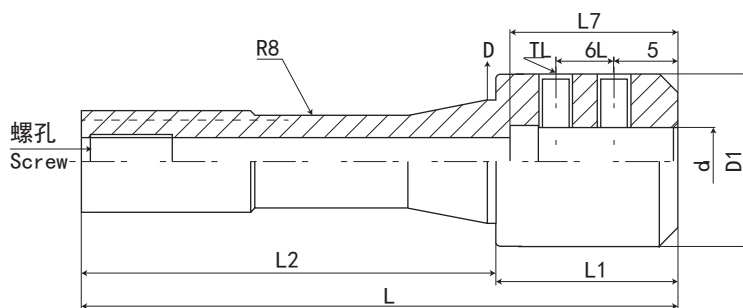

规格 / 型号 Model	L	L1	L2	L5	L6	L7	D	D1	d	T	螺孔 Screw
R8-SLN10-50L	153	50	103	15	14	55	31.75	38	10	M10*1.5P	M12*1.75P-7/16
R8-SLN12-50L	153	50	103	20	16	60	31.75	38	12	M10*1.5P	M12*1.75P-7/16
R8-SLN16-55L	158	55	103	22	18	60	31.75	48	16	M12*1.75P	M12*1.75P-7/16
R8-SLN20-85L	188	85	103	25	20	70	31.75	53	20	M12*1.75P	M12*1.75P-7/16
R8-SLN25-90L	193	90	103	24	25	80	31.75	53	25	M12*1.75P	M12*1.75P-7/16
R8-SLN32-95L	198	95	103	24	28	85	31.75	53	32	M16*2.0P	M12*1.75P-7/16

## R8-ER 后拉式刀柄

## R8-ER COLLET CHUCK



P.131



P.106



P.133

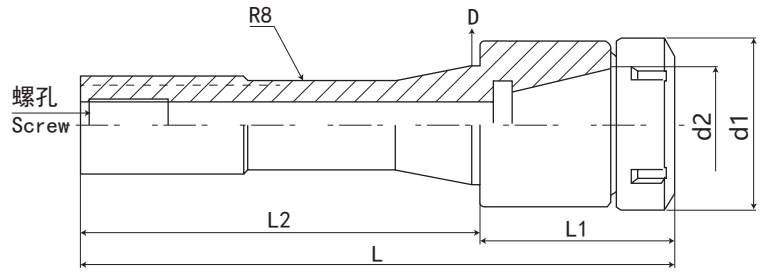

规格 / 型号 Model	L	L1	L2	D	d1	d2	螺孔 Screw
R8-ER16-50L	153	50	103	31.75	28	16	M12*1.5P-7/16
R8-ER20-50L	153	50	103	31.75	34	20	M12*1.5P-7/16
R8-ER25-55L	158	55	103	31.75	42	25	M12*1.5P-7/16
R8-ER32-60L	163	60	103	31.75	50	32	M12*1.5P-7/16
R8-ER40-70L	173	70	103	31.75	63	40	M12*1.5P-7/16

## R8-FMB 铣刀柄

## R8-FMB SHELL END MILL ARBORS



P.L02

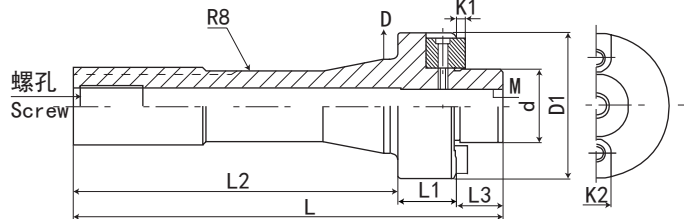

规格 / 型号 Model	L	L1	L2	L3	D	D1	d	M	K1	K2	螺孔 Screw
R8-FMB22-L	151	30	103	18	31.75	40	22	M10*1.5P	4.8	10	M12*1.5P-7/16
R8-FMB27-L	155	32	103	20	31.75	48	27	M12*1.75P	5.8	12	M12*1.5P-7/16
R8-FMB32-L	160	35	103	22	31.75	59	32	M16*2.0P	6.8	14	M12*1.5P-7/16
R8-FMB40-L	163	35	103	25	31.75	64	40	M16*2.0P	8.3	16	M12*1.5P-7/16

## R8 变径套 / 中间套

## R8 MORSE TAPER SLEEVES/TAPER SLEEVES

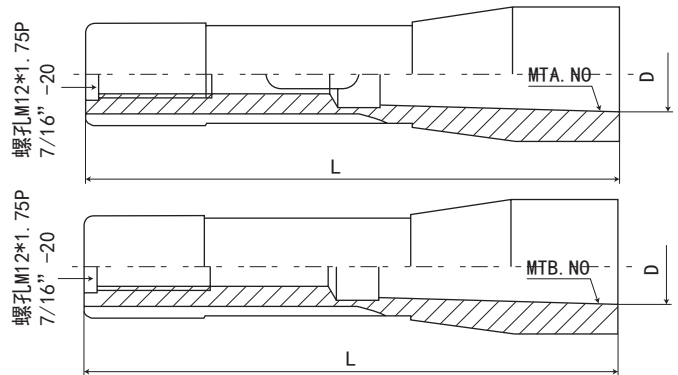

规格 / 型号 Model	MTA.NO	D	L
R8-MTA1	1	12.065	102
R8-MTA2	2	17.780	105
R8-MTA3	3	23.825	135
R8-MTA4	4	31.267	218
规格 / 型号 Model	MTB.NO	D	L
R8-MTB1	1	12.065	114
R8-MTB2	2	17.780	127
R8-MTB3	3	23.825	153
R8-MTB4	4	31.267	240

# 刀柄配件系列 HOLDER ACCESSORIES

## R 8 - 钻接杆

## R8 DRILL CHUCK ARBORS



P.158

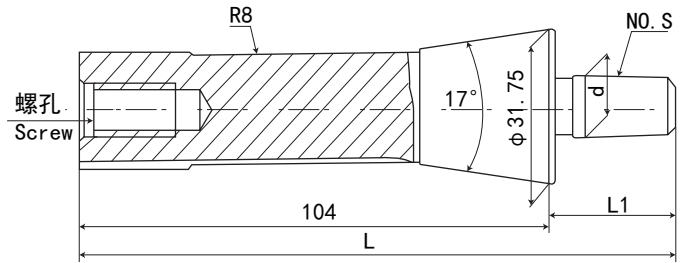

规格 / 型号 Model	L	L1	d	N0.S	螺孔 Screw
R8-JT0	117	14	6.35	JT0	M12*1.75P-7/16
R8-JT1	122	19	9.754	JT1	M12*1.75P-7/16
R8-JT2S	125	22	13.94	JT2S	M12*1.75P-7/16
R8-JT2	128	25	14.199	JT2	M12*1.75P-7/16
R8-JT33	132	29	15.85	JT33	M12*1.75P-7/16
R8-JT6	131	28	17.17	JT6	M12*1.75P-7/16
R8-JT3	137	34	20.599	JT3	M12*1.75P-7/16
R8-JT4	148	45	28.55	JT4	M12*1.75P-7/16
R8-JT5	153	50	35.89	JT5	M12*1.75P-7/16
R8-B6	119	16	6.35	B6	M12*1.75P-7/16
R8-B10	123	20	10.094	B10	M12*1.75P-7/16
R8-B12	127	24	12.065	B12	M12*1.75P-7/16
R8-B16	134	31	15.733	B16	M12*1.75P-7/16
R8-B18	142	39	17.78	B18	M12*1.75P-7/16
R8-B22	151	48	21.793	B22	M12*1.75P-7/16
R8-B24	161	58	23.825	B24	M12*1.75P-7/16

## R8 弹簧夹头

## R8 COLLETS

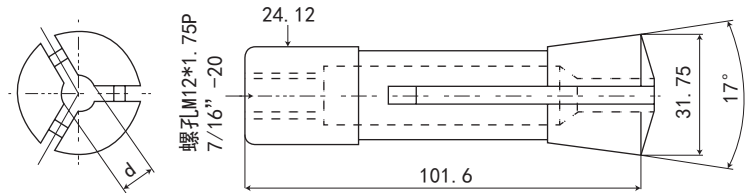

公制螺纹孔为 M12\*1.75P 英制螺纹孔为 7/16" -20

规格 / 型号 Model	型式 Type	夹持范围 Clamping range		重量 KGS
		mm	in	
R8	圆孔 Round	3/4/5/6/7/8/10/12/14/16/18/20	1/16-7/8	0.24

精度检测 INSPECTION OF ACCURACY

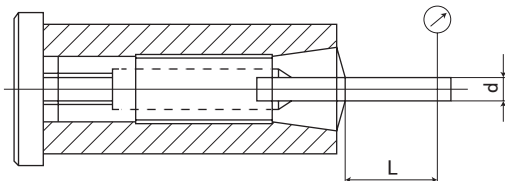

d		L	径向跳动 Run out	
mm	in	mm	in	mm
1-1.6	1/32-1/16	6.35	0.001	0.013
> 1.6-3.0	> 1/16-1/8	12.7	0.001	0.013
> 3-10	> 1/8-3/8	25.4	0.001	0.013
> 10-16	> 3/8-5/8	38.1	0.001	0.013
> 16-20	> 5/8-7/8	50.8	0.001	0.013

### 特点:

- ◎材料: 65Mn
- ◎硬度: 夹持部分 HRC55-60
- ◎弹性区 HRC40-45
- ◎适用于主轴锥孔为 R8 的各种铣床, 如 X6325、X5325 等

### Features:

- ◎ Material: 65Mn
- ◎ Hardness: clamping part HRC55-60
- ◎ elastic part HRC40-45
- ◎ This unit is applicable to all sorts of milling machines, which spindle taper hole is R8, such as X6325、X5325 etc.

## 车床内孔车刀刀套

## LATHE TOOL HOLDER SLEEVE

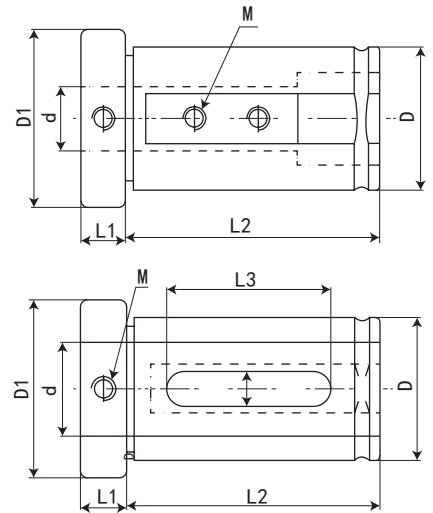

D	d	D1	L1	L2 (加长)	L3 (加长)	W (加宽)	M	FIG
40	8/10/12/16/20	46.5	15	80(85)			M8	1
	25/32	46.5	15	80(85)	65(70)	12(14)		2
32	8/10/12/16	39	14	70(75)			M8	1
	20/25	39	14	70(75)	58(60)	10(12)		2
25	8/10/12	33	14	50				1
	16	33	14	50	42	10		2
20	8/10	28	12	50			M6	1
	12	28	12	50	42	8		2
16	8	24	10	40				1
	10	24	10	40	34	6		2

### 特点:

- ◎高精度 刀库导套 精度有 0.01mm、0.015mm 两类，由合金钢制造，用于数控车加工中心（转塔）刀架夹持刀具
- ◎材料：42CrMo
- ◎热处理硬度：50-55HRC

### Features:

- ◎ High accuracy of sleeve holders 0.01mm,0.015mm,Suitable to hold cylindrical shank tools on turret at CNC lathe.
- ◎ Material:42CrMo
- ◎ Hardness:50-55HRC

## 刀库刀套莫氏锥度套筒

## MORSE TOOL HOLDER SLEEVE

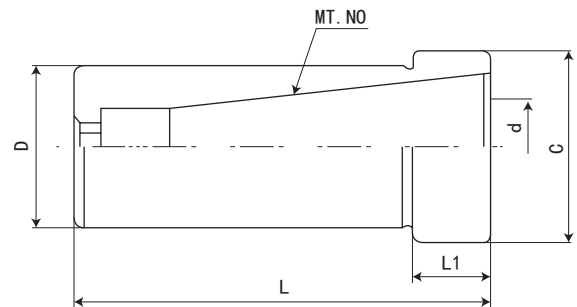

规格 / 型号 Model	FIG	D	C	L	L1	MT		重量 KGS
						MT NO.	d	
C20-MT1	1	20	23.5	76	20	1	12.065	0.16
C20-MT2	1	20	23.5	93	35	2	17.780	0.13
C25-MT1	1	25	31	81	15	1	12.065	0.27
C25-MT2	1	25	31	93	20	2	17.780	0.24
C32-MT1	1	32	37.5	81	15	1	12.065	0.47
C32-MT2	1	32	37.5	91	20	2	17.780	0.46
C32-MT3	2	32	37.5	91	20	3	23.825	0.35
C42-MT1	1	42	47.5	96	20	1	12.065	1.02
C42-MT2	1	42	47.5	96	20	2	17.780	0.93
C42-MT3	2	42	47.5	92	15	3	23.825	0.76
C42-MT4	2	42	47.5	115	30	4	31.267	0.75

# 刀柄配件系列 HOLDER ACCESSORIES

## 车床辅助刀座

## AUXILIARY TOOL HOLDER OF LATHE

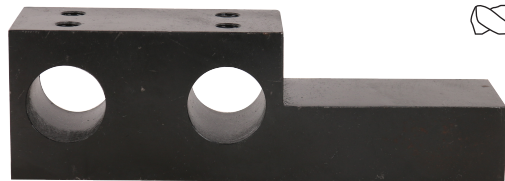
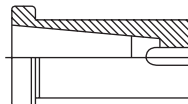
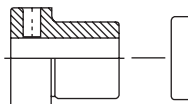
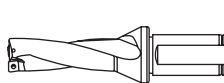
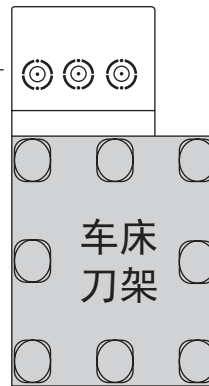
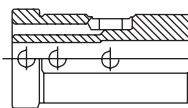
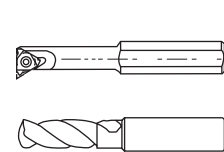
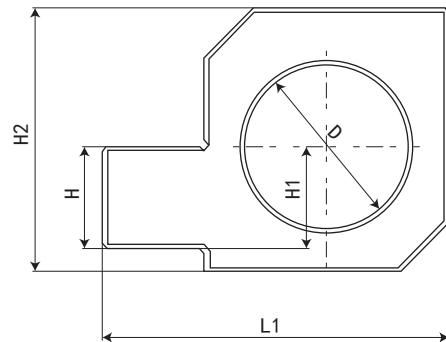
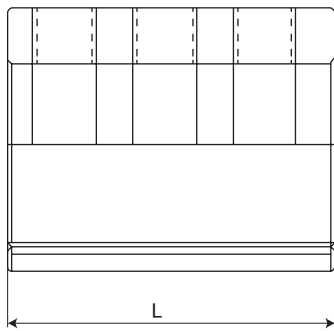

刀柄配件  
HOLDER  
ACCESSORIES

型号	H	H1	H2	L	D
SBHA20-20	20	20	47	65	20
SBHA20-25	20	20	47	65	25
SBHA20-32	20	20	55	85	32
SBHA25-25	25	25	53	70	25
SBHA25-32	25	25	60	85	32
SBHA25-40	25	25	65	90	40
SBHA32-40	32	32	83	100	40
SBHA32-50	32	32	83	100	50
SBHA20-16	20		37	60	16
SBHA25-16	25		42	65	16

## 车床内孔车刀刀套 (小径)

## LATHE TOOL HOLDER SLEEVE (SMALL DIAMETER)

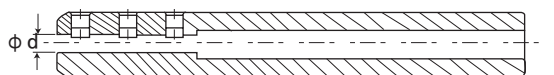
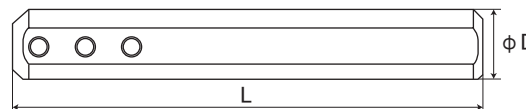
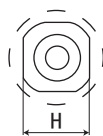

规格 / 型号 Model	d	D	H	L
D12	2 3 4 5 6	12	11	80
D16	2 3 4 5 6 7 8 10	16	15	100
D20	2 3 4 5 6 7 8 10 12	20	19	100
D22	2 3 4 5 6 7 8 10 12	22	21	100



# 扳手钻夹点

## KEY TYPE DRILL CHUCK

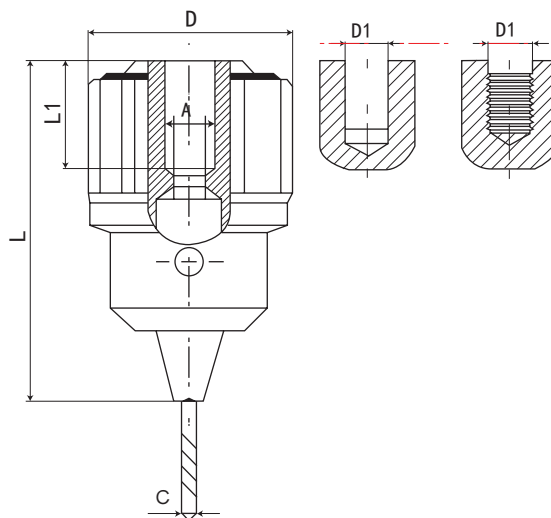

P.S05

产品名称 Product name	型号 Model	规格 Specifications	夹持范围 Range	D	D1	L	L1	重量 KGS
B6 锥孔钻夹头	J214	B6-0.15-4mm	0.15-4	21.7	6.35	34.5	12.5	0.20
JT0 锥孔钻夹头	J224	JT0-0.15-4mm	0.15-4	21.7	6.35	34.5	12.5	0.20
B10 锥孔钻夹头	J216	B10-0.6-6mm	0.6-6	30	10.094	49	17.5	0.28
JT1 锥孔钻夹头	J226	JT1-0.6-6mm	0.6-6	30	9.754	49	19.2	0.28
B12 锥孔钻夹头	J2110	B12-1-10mm	1-10	43	12.065	69	22	0.34
JT2 锥孔钻夹头	J2210	JT2-1-10mm	1-10	43	14.199	69	26	0.34
1/2" 螺孔钻夹头	J3110A	1/2"-1-10mm	1-10	43	1/2"-20UNF	69	17.5	0.34
3/8" 螺孔钻夹头	J3110B	3/8"-1-10mm	1-10	43	3/8"-24UNF	69	16	0.34
M12 螺孔钻夹头	J3110	M12-1-10mm	1-10	43	M12×1.25	69	16	0.34
B16 锥孔钻夹头	J2113	B16-1-13mm	1-13	53	15.733	86	28	0.63
JT6 锥孔钻夹头	J2213	JT6-1-13mm	1-13	53	17.170	86	29	0.63
JT33 锥孔钻夹头	J2213A	JT33-1-13mm	1-13	53	15.850	86	29	0.63
JT3 锥孔钻夹头	J2213B	JT3-1-13mm	1-13	53	20.599	93	35	0.63
1/2" 螺孔钻夹头	J3113A	1/2"-1-13mm	1-13	53	1/2"-20UNF	86	17.5	0.63
3/8" 螺孔钻夹头	J3113B	3/8"-1-13mm	1-13	53	3/8"-24UNF	86	17.5	0.63
M12 螺孔钻夹头	J3113	M12-1-13mm	1-13	53	M12×1.25	86	16	0.63
B18 锥孔钻夹头	J2116B	B18-3-16mm	3-16	53	17.780	86	36	0.65
JT6 锥孔钻夹头	J2616A	JT6-3-16mm	3-16	53	17.170	86	29	0.65
1/2" 螺孔钻夹头	J3116A	1/2"3-16mm	3-16	53	1/2"-20UNF	86	17.5	0.65
5/8" 螺孔钻夹头	J3116B	5/8"3-16mm	3-16	53	5/8"-16UNF	86	19	0.65
B22 锥孔钻夹头	J2120	B22-5-20mm	5-20	65	21.793	107	45	1.4
JT3 锥孔钻夹头	J2220	JT3-5-20mm	5-20	65	20.599	107	35	1.4

### 特点:

- ◎ 适合中、重型钻削
- ◎ 应用于铣床、车床、钻床、木工机械
- ◎ 能够承受高速切削

### Features:

- ◎ Suitable for medium, heavy duty drilling use .
- ◎ For milling machine, lathe, drilling machine, wood working machine.
- ◎ High speed drilling can be performed for possessing high gripping power.

# 刀柄配件系列 HOLDER ACCESSORIES

## 锥孔自紧式钻夹头

## KEYLESS DRILL CHUCK WITH TAPER MOUNTED

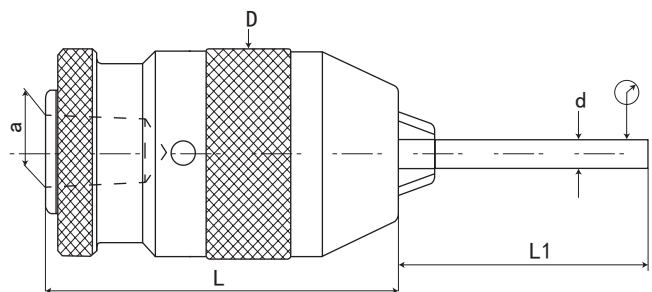

P.S05

P.I31

规格 / 型号 Model	夹持范围 Range	锥孔型号 Cone	a	D	L	L1	d	精度 Accuracy
0.5-6mm-B10	0.5-6mm	B10	10.094	35	61	40	5	≤ 0.07
0.5-8mm-B12	0.5-8mm	B12	12.065	42	84	40	5	≤ 0.07
1-10mm-B12	1-10mm	B12	12.065	42	84	40	5	≤ 0.07
1-13mm-B16	1-13mm	B16	15.733	44	88	40	5	≤ 0.07
1-16mm-B18	1-16mm	B18	17.780	50	98	40	5	≤ 0.07
5-20mm-B22	5-20mm	B22	21.793	54	116	40	5	≤ 0.07
1/64 " -1/4 " -JT1	1/64 " -1/4 "	JT1	9.754	34	61	40	5	≤ 0.07
1/64 " -5/16 " -JT2	1/64 " -5/16 "	JT2	14.199	42	84	40	5	≤ 0.07
1/32 " -3/8 " -JT2	1/32 " -3/8 "	JT2	14.199	44	84	40	5	≤ 0.07
1/32 " -3/8 " -JT33	1/32 " -3/8 "	JT33	15.850	44	84	40	5	≤ 0.07
1/32 " -1/2 " -JT33	1/32 " -1/2 "	JT33	15.850	49	88	40	5	≤ 0.07
1/32 " -1/2 " -JT6	1/32 " -1/2 "	JT6	17.170	49	88	40	5	≤ 0.07
1/8 " -5/8 " -JT6	1/8 " -5/8 "	JT6	17.170	54	98	40	5	≤ 0.07
1/8 " -5/8 " -JT3	1/8 " -5/8 "	JT3	20.599	54	98	40	5	≤ 0.07
3/16 " -3/4 " -JT3	3/16 " -3/4 "	JT3	20.599	60	116	40	5	≤ 0.07

## 螺纹孔自紧式钻夹头

## KEYLESS DRILL CHUCK WITH THREAD MOUNTED

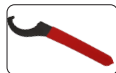
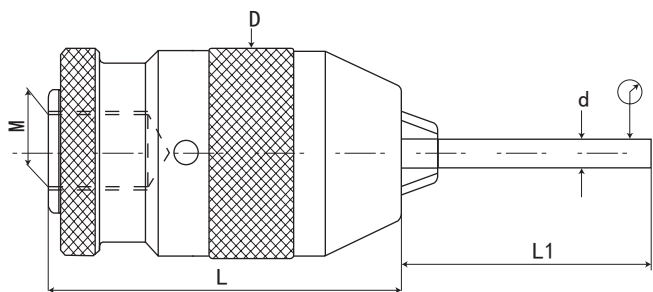

P.I31

规格 / 型号 Model	夹持范围 Range	M	D	L	L1	d	精度 Accuracy
0.5-6mm-M10*1.0P	0.5-8mm	M10*1.0P	34	61	40	5	≤ 0.07
0.5-8mm-M10*1.0P	0.5-8mm	M10*1.0P	40	80	40	5	≤ 0.07
0.5-8mm-M12*1.25P	0.5-8mm	M12*1.25P	40	80	40	5	≤ 0.07
1-10mm-M10*1.0P	1-10mm	M10*1.0P	42	86	40	5	≤ 0.07
1-10mm-M12*1.25P	1-10mm	M12*1.25P	42	86	40	5	≤ 0.07
1-13mm-M10*1.0P	1-13mm	M10*1.0P	44	97	40	5	≤ 0.07
1-13mm-M12*1.25P	1-13mm	M12*1.25P	44	97	40	5	≤ 0.07
1-16mm-M12*1.25P	1-16mm	M12*1.25P	48	107	40	5	≤ 0.07
1-16mm-M16*1.5P	1-16mm	M16*1.5P	48	107	40	5	≤ 0.07
1/64 " -1/4 " -3/8 " -24UNF	1/64 " -1/4 "	3/8 " -24UNF	34	61	40	5	≤ 0.07
1/64 " -5/16 " -3/8 " -24UNF	1/64 " -5/16 "	3/8 " -24UNF	40	80	40	5	≤ 0.07
1/64 " -5/16 " -1/2 " -20UNF	1/64 " -5/16 "	1/2 " -20UNF	40	80	40	5	≤ 0.07
1/32 " -3/8 " -3/8 " -24UNF	1/32 " -3/8 "	3/8 " -24UNF	42	86	40	5	≤ 0.07
1/32 " -3/8 " -1/2 " -20UNF	1/32 " -3/8 "	1/2 " -20UNF	42	86	40	5	≤ 0.07
1/32 " -1/2 " -3/8 " -24UNF	1/32 " -1/2 "	3/8 " -24UNF	44	97	40	5	≤ 0.07
1/32 " -1/2 " -1/2 " -20UNF	1/32 " -1/2 "	1/2 " -20UNF	44	97	40	5	≤ 0.07
1/8 " -5/8 " -1/2 " -20UNF	1/8 " -5/8 "	1/2 " -20UNF	48	107	40	5	≤ 0.07
1/8 " -5/8 " -5/8 " -16UNF	1/8 " -5/8 "	5/8 " -16UNF	48	107	40	5	≤ 0.07

## APU 短锥自紧式钻夹头

## APU SHORT CONE KEYLESS DRILL CHUCK

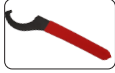

P.131

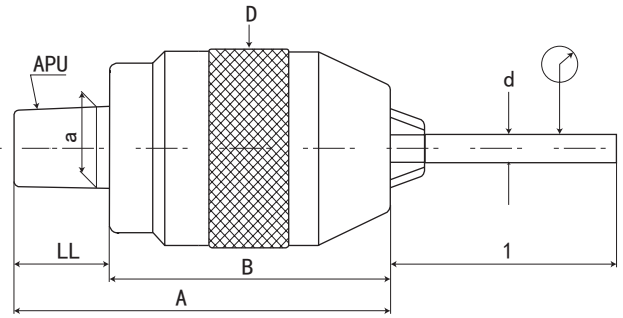

规格 / 型号 Model	夹持范围 Range	短锥型号 (APU)	a	D	A	B	L	L1	d	精度 Accuracy	重量 KGS
APU08	0-8mm	B18	17.780	36	86	62	24	40	5	≤ 0.07	0.45
APU10	1-10mm	B18	17.780	43	102	78	24	40	5	≤ 0.07	0.55
APU13	1-13mm	B24	23.825	50	105	80	25	40	5	≤ 0.07	0.9
APU16	1-16mm	B24	23.825	54	116	91	25	40	5	≤ 0.07	1.25

## C-APU 直柄一体式自紧钻夹头

## C-APU STRAIGHT SHANK KEYLESS DRILL CHUCK



P.131

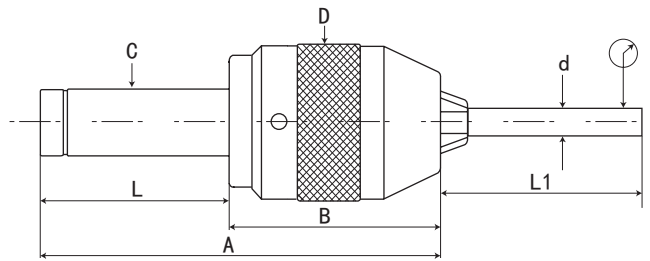

规格 / 型号 Model	夹持范围 Range	直柄型号 (C)	A	B	L	L1	D	d	精度 Accuracy	重量 KGS
C20-APU13	1-13mm	C20	138	78	60	40	49	5	≤ 0.07	0.95
C20-APU16	1-16mm	C20	145	85	60	40	55	5	≤ 0.07	1.2
C25-APU13	1-13mm	C25	158	78	80	40	49	5	≤ 0.07	1.15
C25-APU16	1-16mm	C25	165	85	80	40	55	5	≤ 0.07	1.35
C32-APU13	1-13mm	C32	165	85	80	40	55	5	≤ 0.07	1.55
C32-APU16	1-16mm	C32	165	85	80	40	55	5	≤ 0.07	1.55

## R8-APU 一体式自紧钻夹头

## R8-APU KEYLESS DRILL CHUCK



P.131

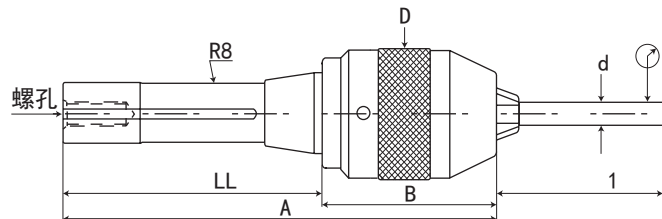

规格 / 型号 Model	夹持范围 Range	锥柄型号 (R8)	A	B	L	L1	D	d	螺孔 Screw	精度 Accuracy	重量 KGS
R8-APU13-M12*1.75P	1-13mm	R8	188	85	103	40	55	5	M12	≤ 0.07	1.45
R8-APU16-M12*1.75P	1-16mm	R8	188	85	103	40	55	5	M12	≤ 0.07	1.45
R8-APU13-7/16-20	1-13mm	R8	188	85	103	40	55	5	7/16	≤ 0.07	1.45
R8-APU16-7/16-20	1-16mm	R8	188	85	103	40	55	5	7/16	≤ 0.07	1.45

# 刀柄配件系列 HOLDER ACCESSORIES

## MTA-APU 莫氏带扁尾一体式自紧钻夹头 MTA-APU MORSE TAPER KEYLESS DRILL CHUCK

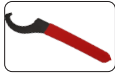
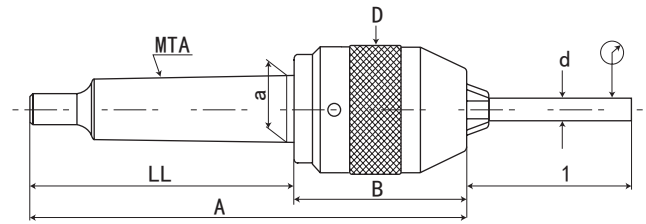

P.131

规格 / 型号 Model	夹持范围 Range	锥柄型号 (MTA)	a	A	B	L	L1	D	d	精度 Accuracy	重量 KGS
MTA2-APU10	1-10mm	MTA2	17.780	159	80	79	40	41	5	≤ 0.07	0.8
MTA2-APU13	1-13mm	MTA2	17.780	158	78	79	40	49	5	≤ 0.07	0.9
MTA2-APU16	1-16mm	MTA2	17.780	164	85	79	40	55	5	≤ 0.07	1.15
MTA3-APU10	1-10mm	MTA3	23.825	178	80	98	40	41	5	≤ 0.07	0.9
MTA3-APU13	1-13mm	MTA3	23.825	183	85	98	40	55	5	≤ 0.07	1.35
MTA3-APU16	1-16mm	MTA3	23.825	183	85	98	40	55	5	≤ 0.07	1.35
MTA4-APU10	1-10mm	MTA4	31.267	204	80	124	40	41	5	≤ 0.07	1.55
MTA4-APU13	1-13mm	MTA4	31.267	209	85	124	40	55	5	≤ 0.07	1.65
MTA4-APU16	1-16mm	MTA4	31.267	209	85	124	40	55	5	≤ 0.07	1.65

## MTB-APU 莫氏后拉式一体式自紧钻夹头 MTB-APU MORSE TAPER KEYLESS DRILL CHUCK

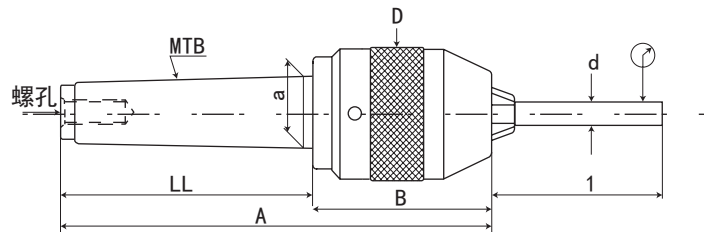

P.131

规格 / 型号 Model	夹持范围 Range	锥柄型号 (MTB)	a	A	B	L	L1	D	d	螺孔 Screw	精度 Accuracy	重量 KGS
MTB2-APU10	1-10mm	MTB2	17.780	149	80	69	40	41	5	M10	≤ 0.07	0.8
MTB2-APU13	1-13mm	MTB2	17.780	147	78	69	40	49	5	M10	≤ 0.07	0.9
MTB2-APU16	1-16mm	MTB2	17.780	154	85	69	40	55	5	M10	≤ 0.07	1.15
MTB3-APU10	1-10mm	MTB3	23.825	166	80	86	40	41	5	M12	≤ 0.07	0.9
MTB3-APU13	1-13mm	MTB3	23.825	171	85	86	40	55	5	M12	≤ 0.07	1.3
MTB3-APU16	1-16mm	MTB3	23.825	171	85	86	40	55	5	M12	≤ 0.07	1.35
MTB4-APU10	1-10mm	MTB4	31.267	188	80	108	40	41	5	M14	≤ 0.07	1.55
MTB4-APU13	1-13mm	MTB4	31.267	193	85	108	40	55	5	M14	≤ 0.07	1.6
MTB4-APU16	1-16mm	MTB4	31.267	193	85	108	40	55	5	M14	≤ 0.07	1.6