

CAT

ANSI B5.50

PRECISION TOOL HOLDERS SYSTEM



CAT数控刀柄系列
CNC TOOL SYSTEMS

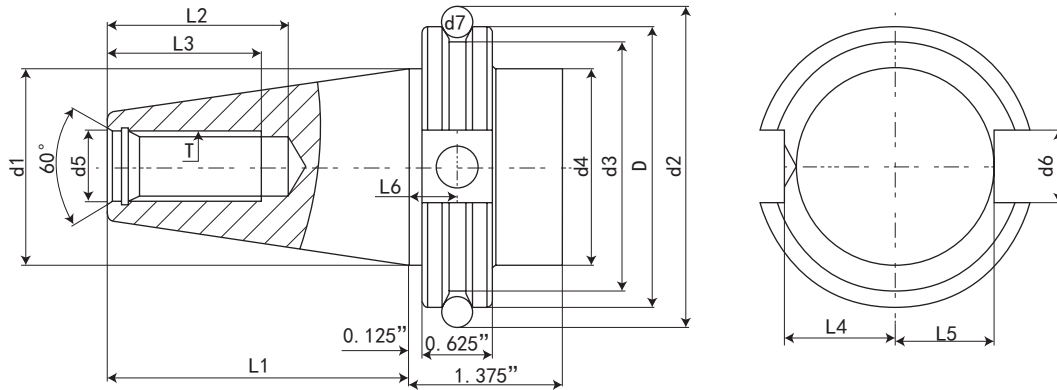

规格 Type	D ±0.002	d1	d2 ±0.002	d3 ±0.01	d4 ±0.005	d5 ±0.0150	d6 ±0.001	d7	L1 ±0.005	L2 Min	L3 ±0.01	L4 +0 -0.015	L5 +0 -0.015	L6 ±0.01	T Unc 2B
CAT30	1.812	1.250	2.176	1.531	1.250	0.516	0.645	0.2813	1.875	1.00	0.188	0.735	0.640	0.440	0.500-13
CAT40	2.500	1.750	2.863	2.219	1.750	0.641	0.645	0.2813	2.687	1.12	0.188	0.985	0.890	0.440	0.625-11
CAT45	3.250	2.250	2.969	2.969	2.250	0.766	0.770	0.2813	3.250	1.50	0.188	1.235	1.140	0.440	0.750-10
CAT50	3.875	2.750	3.594	3.594	2.750	1.031	1.020	0.2813	4.000	1.75	0.250	1.485	1.390	0.440	1.000-8

特点:

注:

- ◎锥度精度 : < AT3
- ◎基本材质 :JIS-SCM415
- ◎硬度 :HRC56°渗碳深度 > 0.8mm
- ◎真圆度 : < 0.8μm
- ◎表面粗糙度 : Ra < 0.5μm
- ◎刀杆本体可另外指定: 通过 V 型法兰端出水规格 (DIN-69871-AD+B)
- ◎ ER、EOC、FMA、FMB、MLC、MLD、SCK、SFC、SKS、SLN (DIN、FID、JIS)、SOM、TG 皆符合: 通过刀柄本体中心出水规格 (DIN-69871-AD)
- ◎刀杆有预设标准动平衡 G6.3, 可另外指定精密动平衡 G2.5
- ◎本体规范: ANSI B5.50

Features:

- ◎ Taper tolerance < AT3.
- ◎ Basic Material:JIS-SCM415
- ◎ Hardness > HRC56° Carbon depth > 0.8mm
- ◎ Roundness < 0.8μm
- ◎ Surface roughness:Ra < 0.5μm
- ◎ If it is suitable for center coolant standard(DIN-69871-AD or B),it can be ordersd.
- ◎ ER、EOC、FMA、FMB、MLC、MLD、SCK、SFC、SKS、SLN (DIN、FID、JIS)、SOM、TG Are in compliance with:Water through the chuck body center type(DIN-69871-AD).
- ◎ The shank has pre-balance at G6.3,and can provide percision balance at G2.5,made by request.
- ◎ Shank body standard:ANSI B5.50



数控刀柄系列 CNC TOOL SYSTEMS

CAT/ER 筒夹刀柄

CAT/ER COLLET CHUCK

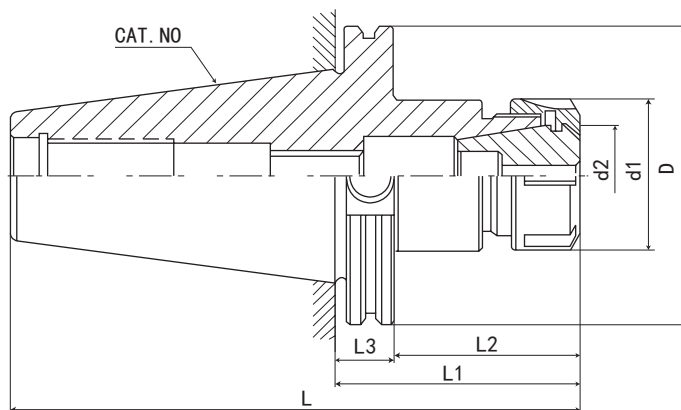

P. 31



P. 106



P. 133

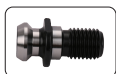

P. 129

数控刀柄
CNC TOOLS

规格 / 型号 Model No.	L	L1	D	d1	d2	d3	T	重量 KGS
CAT40-ER16-2.76"	5.447"	2.76"	2.5"	1.102"	0.63"	1.75	M10*1.5P	1.05
CAT40-ER16-4"	6.687"	4"	2.5"	1.102"	0.63"	1.75	M10*1.5P	1.35
CAT40-ER16-6"	8.687"	6"	2.5"	1.102"	0.63"	1.75	M10*1.5P	1.65
CAT40-ER16-8"	10.687"	8"	2.5"	1.102"	0.63"	1.75	M10*1.5P	1.85
CAT40-ER20-2.76"	5.447"	2.76"	2.5"	1.339"	0.788"	1.75	M12*1.75P	1.25
CAT40-ER20-4"	6.687"	4"	2.5"	1.339"	0.788"	1.75	M12*1.75P	1.65
CAT40-ER25-2.76"	5.447"	1.76"	2.5"	1.654"	0.984"	1.75	M16*2.0P	1.35
CAT40-ER25-4"	6.687"	4"	2.5"	1.654"	0.984"	1.75	M16*2.0P	1.70
CAT40-ER25-6"	8.687"	6"	2.5"	1.654"	0.984"	1.75	M16*2.0P	2.25
CAT40-ER25-8"	10.687"	8"	2.5"	1.654"	0.984"	1.75	M16*2.0P	2.55
CAT40-ER32-2.76"	5.447"	2.76"	2.5"	1.969"	1.26"	1.75	M16*2.0P	1.25
CAT40-ER32-4"	6.687"	4"	2.5"	1.969"	1.26"	1.75	M16*2.0P	1.75
CAT40-ER32-6"	8.687"	6"	2.5"	1.969"	1.26"	1.75	M16*2.0P	2.15
CAT40-ER32-8"	10.687"	8"	2.5"	1.969"	1.26"	1.75	M16*2.0P	2.65
CAT40-ER40-3.15"	5.837"	3.15"	2.5"	2.48"	1.575"	1.75	M20*2.0P	1.80
CAT40-ER40-4"	6.687"	4"	2.5"	2.48"	1.575"	1.75	M20*2.0P	2.05
CAT40-ER40-6"	8.687"	6"	2.5"	2.48"	1.575"	1.75	M20*2.0P	3.30
CAT40-ER50-4"	6.687"	4"	2.5"	3.07"	1.969"	1.75	M24*3.0P	2.65
CAT50-ER16-4"	8"	4"	3.875"	1.102"	0.63"	2.75	M10*1.5P	4.10
CAT50-ER16-6"	10"	6"	3.875"	1.102"	0.63"	2.75	M10*1.5P	4.28
CAT50-ER16-8"	12"	8"	3.875"	1.102"	0.63"	2.75	M10*1.5P	4.40
CAT50-ER20-4"	8"	4"	3.875"	1.339"	0.788"	2.75	M12*1.75P	4.20
CAT50-ER20-6"	10"	6"	3.875"	1.339"	0.788"	2.75	M12*1.75P	4.45
CAT50-ER20-8"	12"	8"	3.875"	1.339"	0.788"	2.75	M12*1.75P	4.60
CAT50-ER25-4"	8"	4"	3.875"	1.654"	0.984"	2.75	M16*2.0P	4.15
CAT50-ER25-6"	10"	6"	3.875"	1.654"	0.984"	2.75	M16*2.0P	4.50
CAT50-ER25-8"	12.3"	8"	3.875"	1.654"	0.984"	2.75	M16*2.0P	4.70
CAT50-ER32-4"	8"	4"	3.875"	1.969"	1.26"	2.75	M16*2.0P	4.35
CAT50-ER32-6"	10"	6"	3.875"	1.969"	1.26"	2.75	M16*2.0P	4.60
CAT50-ER32-8"	12"	8"	3.875"	1.969"	1.26"	2.75	M16*2.0P	4.90
CAT50-ER40-4"	8"	4"	3.875"	2.48"	1.575"	2.75	M20*2.0P	4.25
CAT50-ER40-6"	10"	6"	3.875"	2.48"	1.575"	2.75	M20*2.0P	4.80
CAT50-ER40-8"	12"	8"	3.875"	2.48"	1.575"	2.75	M20*2.0P	5.1
CAT50-ER50-4"	8"	4"	3.875"	3.07"	1.969"	2.75	M24*3.0P	4.85
CAT50-ER50-6"	10"	6"	3.875"	3.07"	1.969"	2.75	M24*3.0P	5.55
CAT50-ER50-8"	12"	8"	3.875"	3.07"	1.969"	2.75	M24*3.0P	5.7

CAT 斜柄钻头套筒

CAT MORSE TAPER ADAPTER

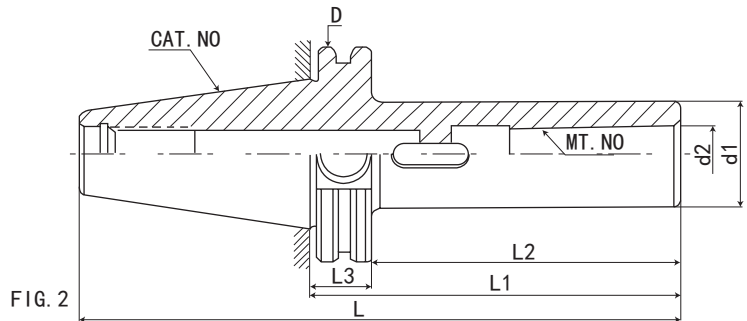
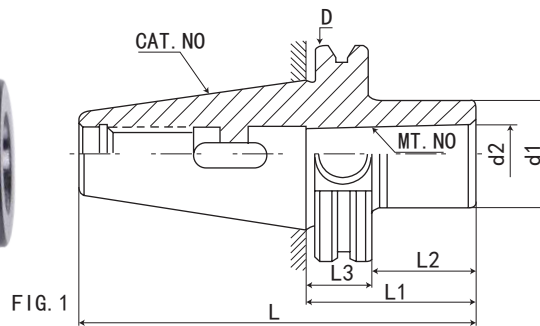

P.129

规格 / 型号 Model No.-11	L	L1	D	d1	d2	重量 KGS
CAT40-MTA1-1.60"	4.287"	2.205"	2.5"	1"	0.475"	1.3
CAT40-MTA2-2.00"	4.687"	2.638"	2.5"	1.25"	0.7"	1.5
CAT40-MTA3-2.75"	5.437"	3.307"	2.5"	1.55"	0.938"	1.8
CAT40-MTA4-3.75"	6.437"	4.213"	2.5"	1.75"	1.23"	2.4
CAT50-MTA1-2.00"	6"	2.205"	3.875"	1"	0.475"	1.05
CAT50-MTA2-2.00"	6"	2.638"	3.875"	1.25"	0.7"	4.4
CAT50-MTA3-2.50"	6.5"	3.307"	3.875"	1.55"	0.938"	4.5
CAT50-MTA4-3.30"	7.3"	4.213"	3.875"	1.75"	1.23"	4.9
CAT50-MTA5-4.10"	8.1"	5.236"	3.875"	2.48"	1.748"	5.15



CNC TOOLS
数控刀柄

CAT 钻接杆刀柄

CAT DRILL CHUCK ARBOR

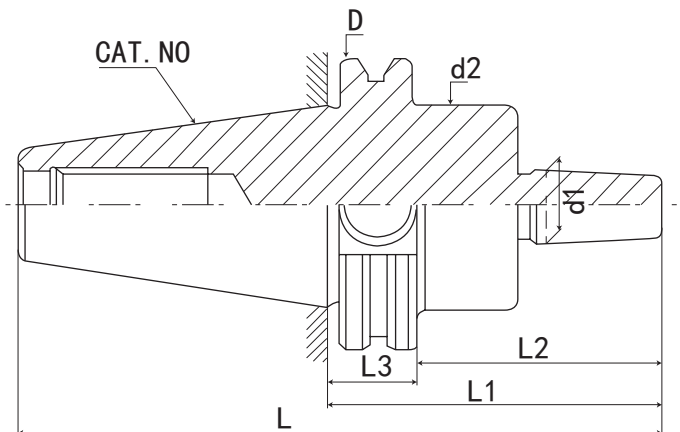

P.31



P.106



P.133

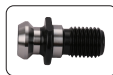

P.129

规格 / 型号 Model No.-11	L	D	d1	d2	T	重量 KGS
CAT40-JTA2-1.57"	5.132"	2.5"	0.559"	1.75"	5/8"-11	1.25
CAT40-XJTA6-1.57"	5.569"	2.5"	0.676"	1.75"	5/8"-11	1.25
CAT40-JTA33-1.57"	5.569"	2.5"	0.624"	1.75"	5/8"-11	1.25
CAT50-JTA2-1.57"	6.445"	3.875"	0.559"	2.75"	1"-8	3.65
CAT50-JTA6-1.57"	6.57"	3.875"	0.676"	2.75"	1"-8	3.65
CAT50-JTA33-1.57"	6.57"	3.875"	0.624"	2.75"	1"-8	3.65

数控刀柄系列 CNC TOOL SYSTEMS

CAT/FMA 平面铣刀柄

CAT FACE MILL ARBORS

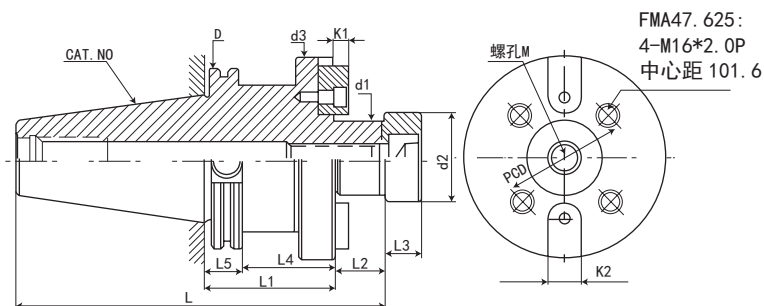

P.I29



P.L02

规格 / 型号 Model No.-11	L	L2	L3	d2	d3	k1	k2	重量 KGS
CAT40-FMA3/4"-1.5"	4.744"	0.687"	0.512"	0.925"	1.69"	0.188"	0.3125"	1.50
CAT40-FMA1"-2.06"	5.434"	0.687"	0.63"	1.240"	2.19"	0.188"	0.375"	2.40
CAT40-FMA1-1/4"-2.21"	5.584"	0.687"	0.63"	1.614"	2.75"	0.25"	0.5"	2.60
CAT40-FMA1-1/2"-2.21"	5.835"	0.938"	0.807"	1.752"	3.81"	0.349"	0.625"	2.70
CAT50-FMA3/4"-1.5"	6.187"	0.687"	0.512"	0.925"	1.69"	0.188"	0.375"	4.20
CAT50-FMA1"-2"	6.687"	0.687"	0.63"	1.240"	2.19"	0.188"	0.375"	4.50
CAT50-FMA1-1/4"-1.5"	6.187"	0.87"	0.63"	1.614"	2.75"	0.25"	0.5"	4.70
CAT50-FMA1-1/2"-2.4"	7.338"	0.938"	0.807"	1.752"	3.81"	0.349"	0.625"	5.00
CAT50-FMA2"-2.4"	7.338"	0.938"	0.807"	2.5"	4.88"	0.384"	0.75"	5.40

CAT-C 型高精度强力刀柄

CAT C FORCE MILLING CHUCK

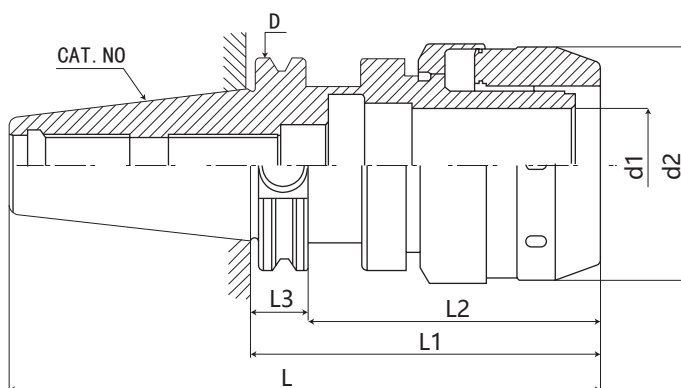

P.I31

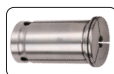

P.I16

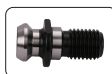

P.I29

规格 / 型号 Model	L	L1	L2	D	d1	d2	N.W.(kg)
CAT40-MLC3/4"-3.385"	6.07	3.385	2.56	2.5	0.75	2.17	1.9
CAT40-MLC3/4"-4.13"	6.82	4.13	2.56	2.5	0.75	2.17	2.1
CAT40-MLC1-1/4"-4.53"	7.22	3.385	2.76	2.5	1.25	2.87	2.4
CAT50-MLC3/4"-4.13"	8.13	4.13	2.56	3.875	0.75	2.17	2.5
CAT50-MLC1-1/4"-4.13"	8.13	4.13	2.76	3.875	1.25	2.87	2.8

CAT-SLN 侧固式刀柄

CAT-SLN SIDE LOCK END MILL HOLDER

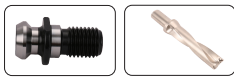
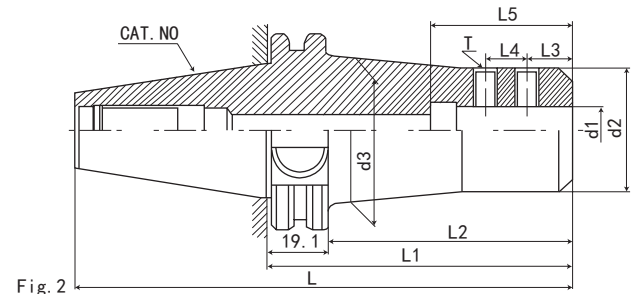
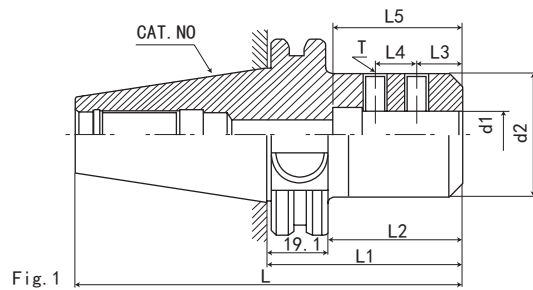

P.129

P.O03

规格 / 型号 Model No.-11	L	L2	L3	d2	d3	k1	k2	重量 KGS
CAT40-SLN1/8"-2.375"	5.062"	0.37"	-	0.787"	4.1"	0.69"	3/16"-24	1.15
CAT40-SLN3/16"-2.5"	5.187"	0.562"	-	0.984"	2.5"	0.69"	1/4"-28	1.20
CAT40-SLN1/4"-3"	5.687"	0.63"	-	1.38"	2.5"	0.78"	1/4"-28	1.15
CAT40-SLN5/16"-3"	5.687"	0.63"	-	1.38"	4.1"	0.88"	5/16"-24	1.20
CAT40-SLN3/8"-3"	5.687"	0.75"	-	1.535"	2.5"	1"	3/8"-24	1.25
CAT40-SLN1/2"-3"	5.687"	0.875"	-	1.732"	2.7"	1.25"	7/16"-20	1.40
CAT40-SLN5/8"-3"	5.687"	0.937"	0.875"	1.85"	3.6"	1.5"	1/2"-20	1.50
CAT40-SLN3/4"-3"	6.187"	1"	1"	1.929"	3.9"	1.75"	5/8"-18	1.65
CAT40-SLN7/8"-3.5"	6.187"	1.063"	1"	2.36"	4.2"	1.88"	5/8"-18	2.55
CAT40-SLN1"-4"	6.687"	1.125"	1"	2.559"	4.4"	2"	3/4"-16	2.80
CAT40-SLN1-1/4"-4.6"	7.287"	1.125"	-	2.559"	4"	2.5"	3/4"-16	2.90
CAT40-SLN1-1/2"-4.5"	7.187"	1.125"	-	2.56"	3"	2.5"	3/4"-16	3.20
CAT50-SLN1/4"-4"	8"	0.63"	-	1.378"	3.4"	0.78"	1/4"-28	3.95
CAT50-SLN5/6"-4"	8"	0.63"	-	1.378"	4.9"	0.88"	5/16"-24	3.95
CAT50-SLN3/8"-4"	8"	0.781"	-	1.535"	3.4"	1"	3/8"-24	4.00
CAT50-SLN1/2"-4"	8"	0.875"	-	1.732"	3.5"	1.25"	7/16"-20	4.15
CAT50-SLN5/8"-4"	8"	0.937"	-	1.85"	4.6"	1.5"	1/2"-20	4.30
CAT50-SLN3/4"-4"	8"	1"	-	1.929"	4.6"	1.75"	5/8"-18	4.35
CAT50-SLN7/8"-4"	8"	1.063"	0.875"	2.362"	4.2"	1.88"	5/8"-18	5.30
CAT50-SLN1"-4"	8"	1.125"	-	2.56"	4.4"	2"	3/4"-16	5.50
CAT50-SLN1-1/4"-4"	8"	1.125"	-	2.756"	4"	2.5"	3/4"-16	5.65
CAT50-SLN1-1/2"-4.6"	8.6"	1.125"	-	2.756"	4"	2.5"	3/4"-16	5.70
CAT50-SLN2"-6"	10"	1.335"	1.41"	3.347"	5"	3.75"	3/4"-16	5.90

CAT-APU 一体式钻夹头刀柄

CAT-APU DRILL CHUCK HOLDER

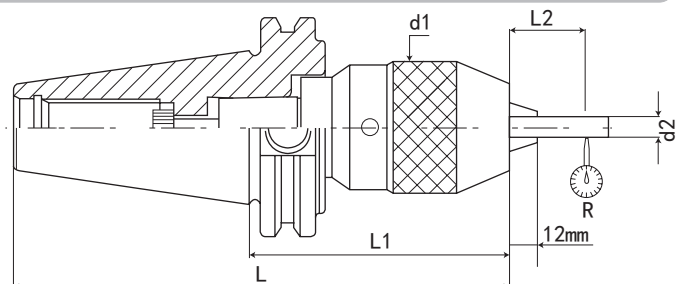

规格 / 型号 Model	L	L2	D	d1	d2	R	N.W.(kg)
CAT40-SPU5/16-3.75"	6.44	2.16	2.500	1.65	0.240	0.040	1.85
CAT40-SPU1/2-4.75"	7.44	2.95	2.500	2.13	0.510	0.040	2.10
CAT40-SPU5/8-6"	8.69	3.15	2.500	2.44	0.510	0.040	2.95
CAT50-SPU5/16-4"	8	2.16	3.875	1.65	0.240	0.040	2.10
CAT50-SPU1/2-4.25"	8.25	2.95	3.875	2.13	0.510	0.040	2.85
CAT50-SPU5/8-4.5"	8.5	3.15	3.875	2.44	0.510	0.040	3.45

CNC TOOLS
数控刀柄

数控刀柄系列 CNC TOOL SYSTEMS

CAT 转换套 (内置夹紧单元)

CAT CONVERSION SLEEVE (CLAMPING CARTRIDGES)

数控刀柄
CNC TOOLS

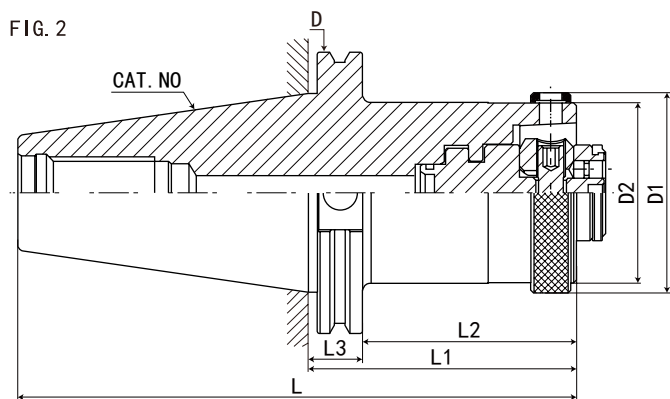
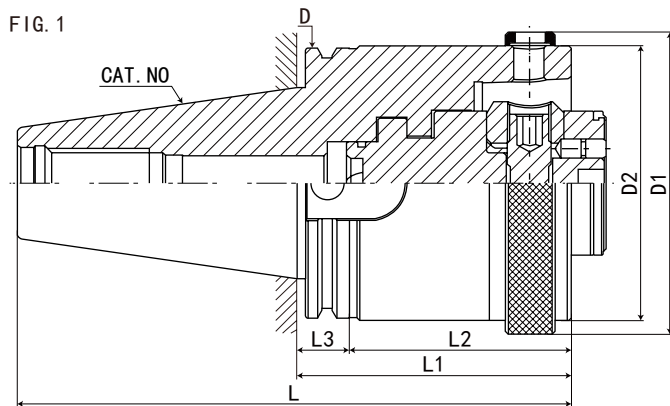

规格	L	L1	L2	L3	D	D1	D2	FIG	重量
CAT30-HSK32C-45C	92.6	45	29	15.9	46	37	32	2	0.7
CAT30-HSK40C-60C	107.6	60	44	15.9	46	45	40	1	0.8
CAT40-HSK32C-50C	118.2	50	34	15.9	63.5	37	32	2	0.9
CAT40-HSK40C-50C	118.2	50	34	15.9	63.5	45	40	2	1
CAT40-HSK50C-60C	128.2	60	44	15.9	63.5	55	50	2	1
CAT40-HSK63C-75C	143.2	75	59	15.9	63.5	70	63	1	1.2
CAT50-HSK32C-50C	151.6	50	34	15.9	98.4	37	32	2	2.7
CAT50-HSK40C-50C	151.6	50	34	15.9	98.4	45	40	2	2.8
CAT50-HSK50C-55C	156.6	55	39	15.9	98.4	55	50	2	2.9
CAT50-HSK63C-55C	156.6	55	39	15.9	98.4	70	63	2	3.1
CAT50-HSK80C-80C	181.6	80	64	15.9	98.4	87	80	2	4
CAT50-HSK100C-95C	196.6	95	79	15.9	98.4	110	100	1	5

CAT40 - HSK - 32C - 45 - C

