

HSK-T

PRECISION TOOL HOLDERS SYSTEM



HSK-T车铣复合刀座
CNC TOOL SYSTEMS

数控刀柄系列 CNC TOOL SYSTEMS

参考资料

REFERENCE DETAILS

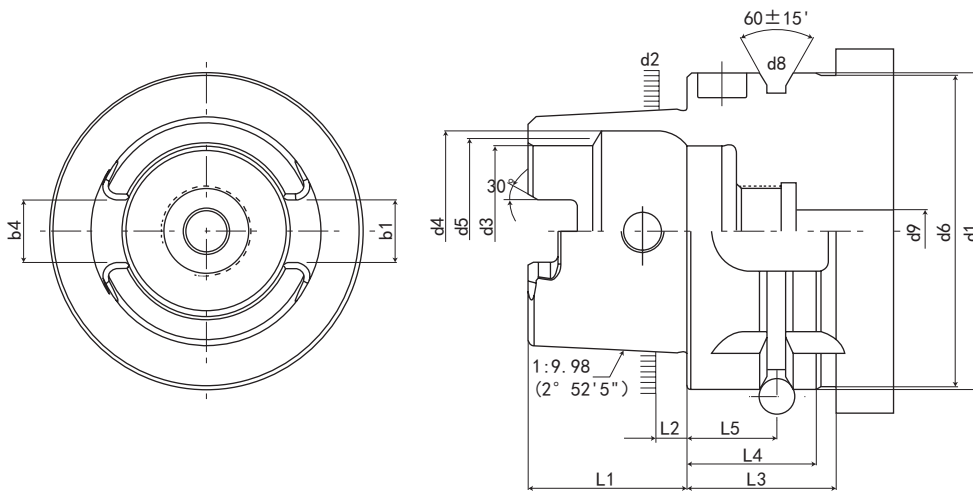

规格 Spec.	d1 h10	d2	d3 H10	d4 H11	d5	d6 Max.	d8	d9 Max.	L1 0 -0.2	L2	L3 Min.	L4 0 -0.1	L5 ±0.1	b1 ±0.04	b4	
HSK-T32	32	24.007	17	20.5	19	31	4	4.2	16	3.2	23	20	16	7.05	6.932	+0.03 0
HSK-T40	40	30.007	21	25.5	23	39	4	5	20	4	23	20	16	8.05	7.932	+0.03 0
HSK-T50	50	38.009	26	32	29	49	7	6.8	25	5	30	26	18	10.54	10.425	+0.035 0
HSK-T63	63	48.010	34	40	37	62	7	8.4	32	6.3	30	26	18	12.54	12.425	+0.035 0
HSK-T80	80	60.012	42	50	46	79	7	10.2	40	8	30	26	18	16.04	15.93	+0.035 0
HSK-T100	100	75.013	53	63	58	99	7	12	50	10	34	26	20	20.02	19.91	+0.035 0

特点:

注:

- ◎ 锥度精度 :<AT3
- ◎ 硬度 :>HRC56°
- ◎ 渗碳深度 :>0.8mm
- ◎ 真圆度 :<0.8μm
- ◎ 表面粗糙度 :Ra<0.25μm
- ◎ 刀杆有预设标准动平衡 G6.3, 可另外指定精密动平衡 G2.5
- ◎ 本体规范 :DIN ISO 12164-3:20008

Features:

- ◎ Taper tolerance <AT3.
- ◎ Hardness>HRC56°
- ◎ Carbon depth>0.8mm.
- ◎ Roundness < 0.8um.
- ◎ Surface roughness: Ra<0.25um.
- ◎ The shank has pre-balance at G6.3,and can provide precision balance at G2.5, made by request.
- ◎ Shank body standard:DIN ISO 12164-3:20008

HSK-T-SBK 外径车铣复合刀座

HSK-T-SBK OUTSIDE DIAMETER TURNING AND MILLING TOOL HOLDER

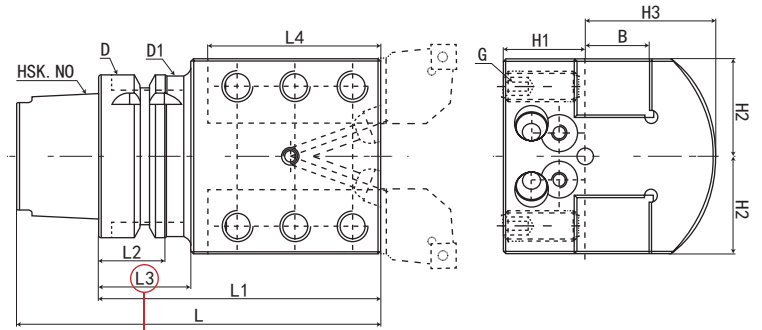
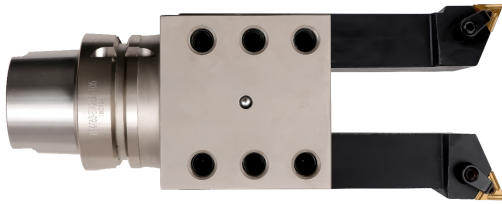

⚠注意 Note

★：请注意防止 ATC 悬臂及机械内的干涉
Please take care to prevent interference within the ATC cantilever and the machine.

不限左右方向
No restriction on left or right hand direction

规格 Model	柄部	L	L1	L2	L3	L4	D	D1	H1	H2	H3	B	G	重量 KGS
HSK-T50-SBK20*20R-95	HSK-T50	120	95	26	31	60	50	48	32	37.75	51	20	M10*1.5P	2
HSK-T63-SBK20*20R-110	HSK-T63	142	110	26	36	60	63	61	32	37.75	51	20	M10*1.5P	2.5
HSK-T63-SBK25*25R-110	HSK-T63	142	110	26	36	67.5	63	61	32	37.75	51	25	M12*1.75P	2.8
HSK-T63-SBK1" *1" R-110	HSK-T63	142	110	26	36	67.5	63	61	32	37.75	51	1"	M12*1.75P	2.8
HSK-T100-SBK25*25R-120	HSK-T100	170	120	29	35	110	100	98	32	37.75	51	25	M12*1.75P	6.5
HSK-T100-SBK1" *1" R-120	HSK-T100	170	120	29	35	110	100	98	32	37.75	51	1"	M12*1.75P	6.5

HSK-T 车铣复合刀座
HSK-T Turning and Milling Tool Holder

数控刀柄系列 CNC TOOL SYSTEMS

HSK-T-SBN 外径车铣复合刀座

HSK-T-SBN OUTSIDE DIAMETER TURNING AND MILLING TOOL HOLDER

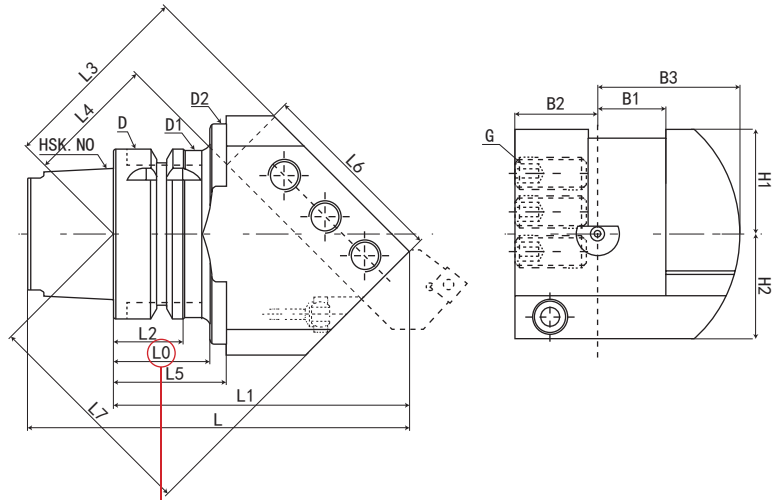

注意 Note
 ★: 请注意防止 ATC 悬臂及机械内的干涉
 Please take care to prevent interference within the ATC cantilever and the machine.

本图表示右手车刀 (R)
 This diagram shows a right hand turning tool (R)

HSK-T 车铣复合刀座
 HSK-T turning and milling tool holder

规格	柄部	L	L0	L1	L2	L3	L4	L5	L6	L7	D	D1	D2	B1	B2	B3	H1	H2	G	重量 KGS
HSK-T50-SBN20*20R-110	HSK-T50	135	31	110	26	72.8	52.8	*	60	83.1	50	48	*	20	25	43.5	35	35	M10*1.5P	2.4
HSK-T50-SBN20*20L-110	HSK-T50	135	31	110	26	72.8	52.8	*	60	83.1	50	48	*	20	25	43.5	35	35	M10*1.5P	2.4
HSK-T63-SBN20*20R-110	HSK-T63	142	32	110	26	72.8	52.8	*	60	83.1	63	61	*	20	32	43.5	35	35	M10*1.5P	2.9
HSK-T63-SBN20*20L-110	HSK-T63	142	32	110	26	72.8	52.8	*	60	83.1	63	61	*	20	32	43.5	35	35	M10*1.5P	2.9
HSK-T63-SBN25*25R-110	HSK-T63	142	32	110	26	70.8	45.8	40	70	85.2	63	61	90	25	32	53	39	39	M12*1.75P	3.2
HSK-T63-SBN25*25L-110	HSK-T63	142	32	110	26	70.8	45.8	40	70	85.2	63	61	90	25	32	53	39	39	M12*1.75P	3.2
HSK-T63-SBN1" *-1" R-110	HSK-T63	142	32	110	26	70.8	45.8	40	70	85.2	63	61	90	1"	32	53	39	39	M12*1.75P	3.2
HSK-T63-SBN1" *-1" L-110	HSK-T63	142	32	110	26	70.8	45.8	40	70	85.2	63	61	90	1"	32	53	39	39	M12*1.75P	3.2
HSK-T100-SBN25*25R-135	HSK-T100	185	35	135	29	88.5	63.5	*	70	102.9	100	98	*	25	32	59	43	43	M12*1.75P	6.4
HSK-T100-SBN25*25L-135	HSK-T100	185	35	135	29	88.5	63.5	*	70	102.9	100	98	*	25	32	59	43	43	M12*1.75P	6.4
HSK-T100-SBN1" *-1" R-135	HSK-T100	185	35	135	29	88.5	63.5	*	70	102.9	100	98	*	1"	32	59	43	43	M12*1.75P	6.4
HSK-T100-SBN1" *-1" L-135	HSK-T100	185	35	135	29	88.5	63.5	*	70	102.9	100	98	*	1"	32	59	43	43	M12*1.75P	6.4
HSK-T100-SBN32*32R-140	HSK-T100	190	35	140	29	89	59	*	85	109.9	100	98	*	32	37	68.5	48	43	M14*2.0P	7.2
HSK-T100-SBN32*32L-140	HSK-T100	190	35	140	29	89	59	*	85	109.9	100	98	*	32	37	68.5	48	43	M14*2.0P	7.2

HSK-T-SBH 外径车铣复合刀座

HSK-T-SBH OUTSIDE DIAMETER TURNING AND MILLING TOOL HOLDER

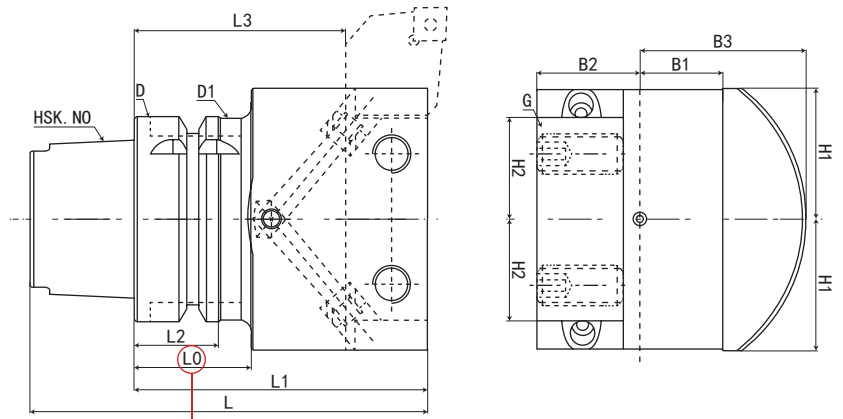

⚠注意 Note
 ★: 请注意防止 ATC 悬臂及机械内的干涉
 Please take care to prevent interference within the ATC cantilever and the machine.

不限左右方向
 No restriction on left or right hand direction

规格	柄部	L	L0	L1	L2	L3	D	D1	B1	B2	B3	H1	H2	G	重量 KGS
HSK-T50-SBH20*20R-90	HSK-T50	115	40	90	26	70	50	48	20	25	43.5	27.5	*	M10*1.5P	1.8
HSK-T50-SBH20*20R-120	HSK-T50	145	70	120	26	100	50	48	20	25	43.5	27.5	*	M10*1.5P	2.3
HSK-T63-SBH20*20R-90	HSK-T63	122	40	90	26	70	63	61	20	32	4.35	30	*	M10*1.5P	2.5
HSK-T63-SBH25*25R-90	HSK-T63	122	40	90	26	65	63	61	25	32	53	40.5	29.5	M12*1.75P	3.1
HSK-T63-SBH1" *-1" R-90	HSK-T63	122	40	90	26	65	63	61	1"	32	53	40.5	29.5	M12*1.75P	3.1
HSK-T63-SBH25*25R-120	HSK-T63	152	70	120	26	95	63	61	25	32	53	40.5	29.5	M12*1.75P	3.7
HSK-T63-SBH1" *-1" R-120	HSK-T63	152	70	120	26	95	63	61	1"	32	53	40.5	29.5	M12*1.75P	3.7
HSK-T100-SBH25*25R-105	HSK-T100	155	35	105	29	80	100	98	25	32	59	48	37	M12*1.75P	6.1
HSK-T100-SBH1" *-1" R-105	HSK-T100	155	35	105	29	80	100	98	1"	32	59	48	37	M12*1.75P	6.1
HSK-T100-SBH25*25R-150	HSK-T100	200	35	150	29	125	100	98	25	32	59	48	37	M12*1.75P	8.9
HSK-T100-SBH32*32R-105	HSK-T100	155	35	105	29	75	100	98	32	40	68.5	57	43	M14*2.0P	7.4



数控刀柄系列 CNC TOOL SYSTEMS

HSK-T-SBV 外径车铣复合刀座

HSK-T-SBV OUTSIDE DIAMETER TURNING AND MILLING TOOL HOLDER

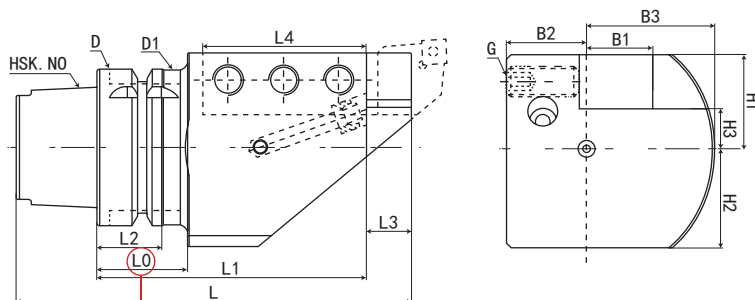

注意 Note

★：请注意防止 ATC 悬臂及机械内的干涉
Please take care to prevent interference within the ATC cantilever and the machine.

本图表示右手车刀 (R)
This diagram shows a right hand turning tool (R)



HSK-T 车铣复合刀座
HSK-T Turning and Milling Tool Holder

规格	柄部	L	L0	L1	L2	L3	L4	D	D1	B1	B2	B3	H1	H2	H3	G	重量 GS
HSK-T50-SBV20*20R-95	HSK-T50	120	31	95	26	15	60	50	48	20	25	43.5	25	25	5	M10*1.5P	2
HSK-T50-SBV20*20L-95	HSK-T50	120	31	95	26	15	60	50	48	20	25	43.5	25	25	5	M10*1.5P	2
HSK-T63-SBV20*20R-95	HSK-T63	127	32	95	26	15	60	63	61	20	32	43.5	33	32	13	M10*1.5P	2.7
HSK-T63-SBV20*20L-95	HSK-T63	127	32	95	26	15	60	63	61	20	32	43.5	33	32	13	M10*1.5P	2.7
HSK-T63-SBV25*25R-105	HSK-T63	137	32	105	26	20	70	63	61	25	32	45	30	30	5	M12*1.75P	2.9
HSK-T63-SBV25*25L-105	HSK-T63	137	32	105	26	20	70	63	61	25	32	45	30	30	5	M12*1.75P	2.9
HSK-T63-SBV1" *-1" R-105	HSK-T63	137	32	105	26	20	70	63	61	25	32	45	30	30	5	M12*1.75P	2.9
HSK-T63-SBV1" *-1" L-105	HSK-T63	137	32	105	26	20	70	63	61	25	32	45	30	30	5	M12*1.75P	2.9
HSK-T100-SBV25*25R-150	HSK-T100	200	35	150	29	20	110	100	98	25	37	59	48	43	23	M12*1.75P	8.5
HSK-T100-SBV25*25L-150	HSK-T100	200	35	150	29	20	110	100	98	25	37	59	48	43	23	M12*1.75P	8.5
HSK-T100-SBV1" *-1" R-150	HSK-T100	200	35	150	29	20	110	100	98	1"	37	59	48	43	23	M12*1.75P	8.5
HSK-T100-SBV1" *-1" L-150	HSK-T100	200	35	150	29	20	110	100	98	1"	37	59	48	43	23	M12*1.75P	8.5
HSK-T100-SBV32*32R-150	HSK-T100	200	35	150	29	20	110	100	98	32	40	68.5	45	43	15	M14*2.0P	9
HSK-T100-SBV32*32L-150	HSK-T100	200	35	150	29	20	110	100	98	32	40	68.5	45	43	15	M14*2.0P	9

HSK-T-SBT 外径车铣复合刀座

HSK-T-SBT OUTSIDE DIAMETER TURNING AND MILLING TOOL HOLDER

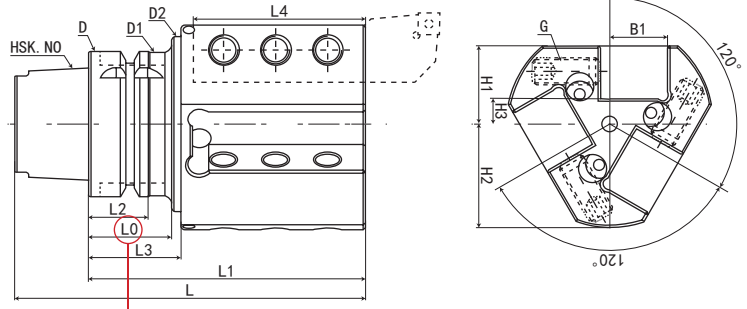

△注意 Note
 ★: 请注意防止 ATC 悬臂及机械内的干涉
 Please take care to prevent interference within the ATC cantilever and the machine.

本图表示右手车刀 (R)
 This diagram shows a right hand turning tool (R)

规格	柄部	L	L0	L1	L2	L3	L4	D	D1	D2	B1	H1	H2	H3	G	重量 KGS
HSK-T50-SBT20*20R-95	HSK-T50	120	31	95	26	*	60	50	48	*	20	35	43.5	15	M10*1.5P	2.3
HSK-T50-SBT20*20L-95	HSK-T50	120	31	95	26	*	60	50	48	*	20	35	43.5	15	M10*1.5P	2.3
HSK-T63-SBT20*20R-95	HSK-T63	127	32	95	26	*	60	63	61	*	20	35	43.5	15	M10*1.5P	2.6
HSK-T63-SBT20*20L-95	HSK-T63	127	32	95	26	*	60	63	61	*	20	35	43.5	15	M10*1.5P	2.6
HSK-T63-SBT25*25R-115	HSK-T63	147	32	115	26	40	70	63	61	90	25	43	53	18	M12*1.75P	4.4
HSK-T63-SBT25*25L-115	HSK-T63	147	32	115	26	40	70	63	61	90	25	43	53	18	M12*1.75P	4.4
HSK-T63-SBT1" *-1" R-115	HSK-T63	147	32	115	26	40	70	63	61	90	25	43	53	18	M12*1.75P	4.4
HSK-T63-SBT1" *-1" L-115	HSK-T63	147	32	115	26	40	70	63	61	90	25	43	53	18	M12*1.75P	4.4
HSK-T100-SBT25*25R-150	HSK-T100	200	35	150	29	*	110	100	98	*	25	48	59	23	M12*1.75P	8.9
HSK-T100-SBT25*25L-150	HSK-T100	200	35	150	29	*	110	100	98	*	25	48	59	23	M12*1.75P	8.9
HSK-T100-SBT1" *-1" R-150	HSK-T100	200	35	150	29	*	110	100	98	*	25	48	59	23	M12*1.75P	8.9
HSK-T100-SBT1" *-1" L-150	HSK-T100	200	35	150	29	*	110	100	98	*	25	48	59	23	M12*1.75P	8.9



数控刀柄系列 CNC TOOL SYSTEMS

HSK-T-TSB 内径车铣复合刀座【镗刀杆用】

HSK-T-TSB INNER DIAMETER TURNING AND MILLING TOOL HOLDER (FOR BORING BAR)



FIG. 1

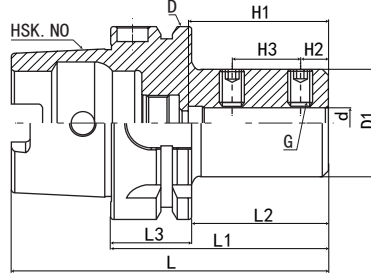

FIG. 2

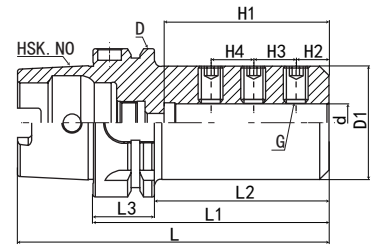

FIG. 3

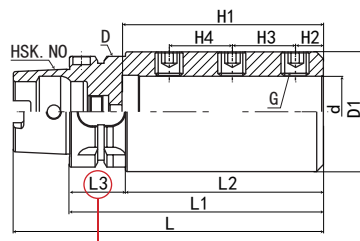
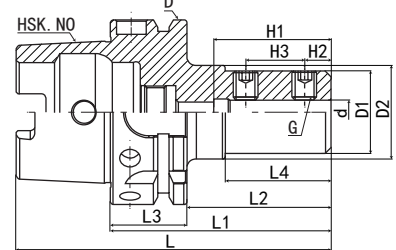

FIG. 4



注意 Note
★：请注意防止 ATC 悬臂及机械内的干涉
Please take care to prevent interference within the ATC cantilever and the machine.

HSK-T 车铣复合刀座
HSK-T turning and milling tool holder

规格	柄部	L	L1	L2	L3	L4	D	D1	D2	d	H1	H2	H3	H4	G	FIG	重量 KGS
HSK-T50-TSB8-65	HSK-T50	90	65	39	26	*	50	28	*	8	40	9	20	*	M8*1.25P	1	0.7
HSK-T50-TSB10-70	HSK-T50	95	70	44	26	*	50	35	*	10	45	9	22	*	M8*1.25P	1	0.8
HSK-T50-TSB12-75	HSK-T50	100	75	49	26	*	50	42	*	12	50	9	22	*	M8*1.25P	1	1
HSK-T50-TSB16-95	HSK-T50	120	95	69	26	*	50	48	*	16	70	14	18	18	M10*1.5P	2	1.3
HSK-T50-TSB20-95	HSK-T50	120	95	69	26	*	50	52	*	20	70	14	18	18	M10*1.5P	3	1.4
HSK-T50-TSB25-110	HSK-T50	135	110	84	26	*	50	62	*	25	85	14	26	26	M12*1.75P	3	2.1
HSK-T50-TSB32-125	HSK-T50	150	125	99	26	*	50	62	*	32	100	14	30	30	M12*1.75P	3	2.1
HSK-T63-TSB8-65	HSK-T63	97	65	39	26	*	63	28	*	8	40	9	20	*	M8*1.25P	1	0.9
HSK-T63-TSB10-70	HSK-T63	102	70	44	26	*	63	35	*	10	45	9	22	*	M8*1.25P	1	1.1
HSK-T63-TSB12-75	HSK-T63	107	75	49	26	*	63	42	*	12	50	9	22	*	M8*1.25P	1	1.2
HSK-T63-TSB16-100	HSK-T63	132	100	74	26	*	63	48	*	16	70	14	18	18	M10*1.5P	2	1.7
HSK-T63-TSB20-100	HSK-T63	132	100	74	26	*	63	52	*	20	70	14	18	18	M10*1.5P	2	1.8
HSK-T63-TSB25-115	HSK-T63	147	115	89	26	*	63	62	*	25	85	14	26	26	M12*1.75P	2	2.5
HSK-T63-TSB32-130	HSK-T63	162	130	104	26	*	63	62	*	32	100	14	30	30	M12*1.75P	2	2.6
HSK-T63-TSB40-145	HSK-T63	177	145	119	26	*	63	68	*	40	115	16	36	36	M16*2.0P	3	2.9
HSK-T100-TSB8-75	HSK-T100	125	75	46	29	36	100	28	32	8	40	9	20	*	M8*1.25P	4	2.4
HSK-T100-TSB10-80	HSK-T100	130	80	51	29	*	100	35	*	10	45	9	22	*	M8*1.25P	1	2.5
HSK-T100-TSB12-85	HSK-T100	135	85	56	29	*	100	42	*	12	50	9	22	*	M8*1.25P	1	2.7
HSK-T100-TSB16-105	HSK-T100	155	105	76	29	*	100	48	*	16	70	14	18	18	M10*1.5P	2	3.1
HSK-T100-TSB20-105	HSK-T100	155	105	76	29	*	100	52	*	20	70	14	18	18	M10*1.5P	2	3.2
HSK-T100-TSB25-120	HSK-T100	170	120	91	29	*	100	62	*	25	85	14	26	26	M12*1.75P	2	4
HSK-T100-TSB32-135	HSK-T100	185	135	106	29	*	100	72	*	32	100	14	30	30	M12*1.75P	2	4.9
HSK-T100-TSB40-150	HSK-T100	200	150	121	29	*	100	82	*	40	115	16	36	36	M16*2.0P	2	6
HSK-T100-TSB50-180	HSK-T100	230	180	151	29	*	100	92	*	50	145	18	38	38	M16*2.0P	2	7.8

TSB40 转换套

TSB40 CONVERSION SLEEVE

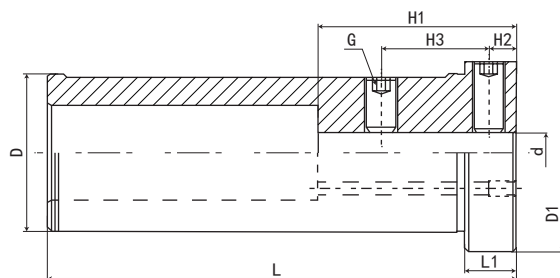
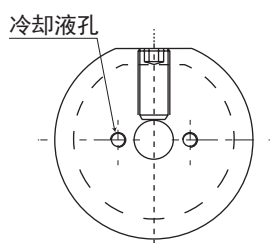

规格	L	L1	D	D1	d	H1	H2	H3	G	重量 KGS
TSB40-8	118	13	40	50	8	50	7	34	M8*1.25P	1
TSB40-10	118	13	40	50	10	50	7	34	M8*1.25P	1
TSB40-12	118	13	40	50	12	60	7	34	M8*1.25P	1
TSB40-16	118	13	40	50	16	70	7	34	M8*1.25P	0.9



HSK 车铣复合刀座
HSK Turning Milling Tool Holder

数控刀柄系列 CNC TOOL SYSTEMS

HSK-T-TSD 内径车铣复合刀座【钻头用】

HSK-T-TSD INNE-R DIAMETER TURNING AND MILLING TOOL HOLDER (FOR DRILL)

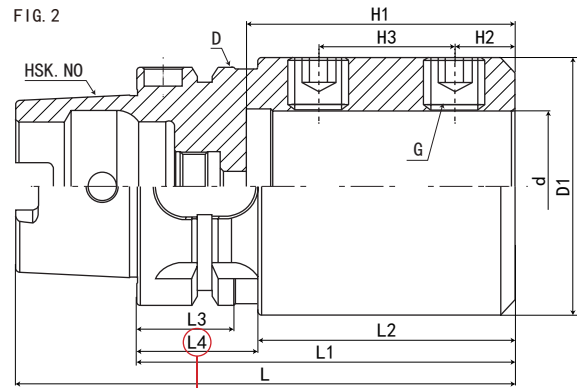
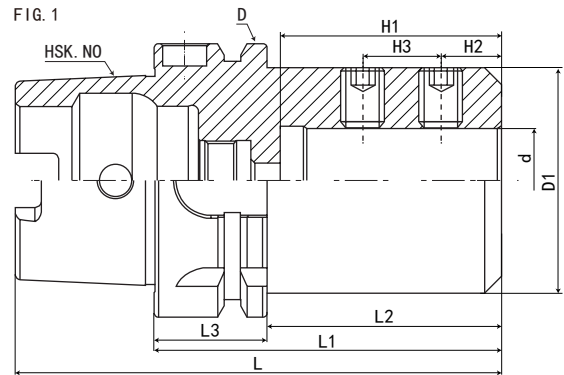

△注意 Note

★：请注意防止 ATC 悬臂及机械内的干涉
Please take care to prevent interference within the ATC cantilever and the machine.

规格	柄部	L	L1	L2	L3	L4	D	D1	d	H1	H2	H3	G	FIG	重量 KGS
HSK-T50-TSD8-65	HSK-T50	90	65	39	26	*	50	28	8	34	10	18	M8*1.25P	1	0.8
HSK-T50-TSD10-65	HSK-T50	90	65	39	26	*	50	35	10	39	12	20	M8*1.25P	1	0.9
HSK-T50-TSD12-70	HSK-T50	95	70	44	26	*	50	42	12	39	12	20	M8*1.25P	1	1
HSK-T50-TSD16-75	HSK-T50	100	75	49	26	*	50	48	16	49	14	18	M10*1.5P	1	1.1
HSK-T50-TSD20-80	HSK-T50	105	80	54	26	31	50	52	20	51	14	18	M10*1.5P	2	1.2
HSK-T50-TSD25-85	HSK-T50	110	85	59	26	31	50	62	25	57	14	26	M12*1.75P	2	1.6
HSK-T50-TSD32-90	HSK-T50	115	90	64	26	31	50	62	32	61	14	30	M12*1.75P	2	1.6
HSK-T63-TSD8-65	HSK-T63	97	65	39	26	*	63	28	8	34	10	18	M8*1.25P	1	0.84
HSK-T63-TSD10-70	HSK-T63	102	70	44	26	*	63	35	10	39	12	20	M8*1.25P	1	0.97
HSK-T63-TSD12-70	HSK-T63	102	70	44	26	*	63	42	12	39	12	20	M8*1.25P	1	1.1
HSK-T63-TSD16-75	HSK-T63	107	75	49	26	*	63	48	16	49	14	18	M10*1.5P	1	1.4
HSK-T63-TSD20-80	HSK-T63	112	80	54	26	*	63	52	20	51	14	18	M10*1.5P	1	1.5
HSK-T63-TSD25-85	HSK-T63	117	85	59	26	*	63	62	25	57	14	26	M12*1.75P	1	1.9
HSK-T63-TSD32-90	HSK-T63	122	90	64	26	*	63	62	32	61	14	30	M12*1.75P	1	1.9
HSK-T63-TSD40-100	HSK-T63	132	100	74	26	32	63	68	40	71	16	36	M16*2.0P	2	2.1
HSK-T100-TSD8-70	HSK-T100	120	70	41	29	*	100	28	8	34	10	18	M8*1.25P	1	2.5
HSK-T100-TSD10-75	HSK-T100	125	75	46	29	*	100	35	10	39	12	20	M8*1.25P	1	2.6
HSK-T100-TSD12-75	HSK-T100	125	75	46	29	*	100	42	12	39	12	20	M8*1.25P	1	2.7
HSK-T100-TSD16-85	HSK-T100	135	85	56	29	*	100	48	16	49	14	18	M10*1.5P	1	2.9
HSK-T100-TSD20-85	HSK-T100	135	85	56	29	*	100	52	20	51	14	18	M10*1.5P	1	2.9
HSK-T100-TSD25-90	HSK-T100	140	90	61	29	*	100	62	25	57	14	26	M12*1.75P	1	3.3
HSK-T100-TSD32-95	HSK-T100	145	95	66	29	*	100	72	32	61	14	30	M12*1.75P	1	3.9
HSK-T100-TSD40-105	HSK-T100	155	105	76	29	*	100	82	40	71	16	36	M16*2.0P	1	4.6
HSK-T100-TSD50-115	HSK-T100	165	115	86	29	*	100	92	50	81	18	38	M16*2.0P	1	5.3

车刀规格介绍

DISPLAY FOR TURNING TOOLS

锁固方式 CLAMP MECHANISM			
A	BACK CLAMP SYSTEM	M	MULTI-CLAMP SYSTEM
C	CLAMP-ON SYSTEM	P	PIN LOCK SYSTEM
D	DOUBLE CLAMP SYSTEM	S	SCREW-ON SYSTEM
E	OFF-SET PIN SYSTEM	T	TAPER LOCK SYSTEM
JS	SCREW-ON SYSTEM	W	WEDGE-ON SYSTEM
JT	BACK CLAMP SYSTEM		

高隙角 INSERT CLEARANCE	
A	3°
B	5°
C	7°
D	15°
E	20°
F	25°
G	30°
N	0°
P	11°

刀具长度 INSERT EDGE LENGTH					
Insert inscribed circle	6.35	7.94	9.525	12.00	12.70
80°	06	08	09	-	12
55°	07	-	11	-	15
35°	11	-	16	-	-
	-	-	-	12	-
	11	13	16	-	22
	-	-	09	-	12

HSK-T63 -- M C L N R 45 065 - 12

刀片形状 INSERT GEOMETRY	
C	80°
D	55°
K	55°
R	
S	
T	
V	35°
W	80°
L	
H	120°
A	85°
B	82°
E	75°
M	86°
O	135°
P	108°

进刀角度 CUTTING EDGE GEMOETRY			
90° 	75° 	90° 	45°
A 60° 	B 90° 	C 90° 	D 107.5°
E 93° 	F 75° 	G 95° 	H 50°
J 63° 	K 117.5° 	L 75° 	M 45°
N 60° 	P 93° 	R 72.5° 	S 60°
T 85° 	U 	V 	W
Y 			

切削方向 HAND
R
L
N

D1 尺寸 D1 DIMENSION

刀具尺寸 TOOL LENGTH METRIC



数控刀柄系列 CNC TOOL SYSTEMS

DCLN 外径车刀

DCLN EXTERNAL TURNING TOOL

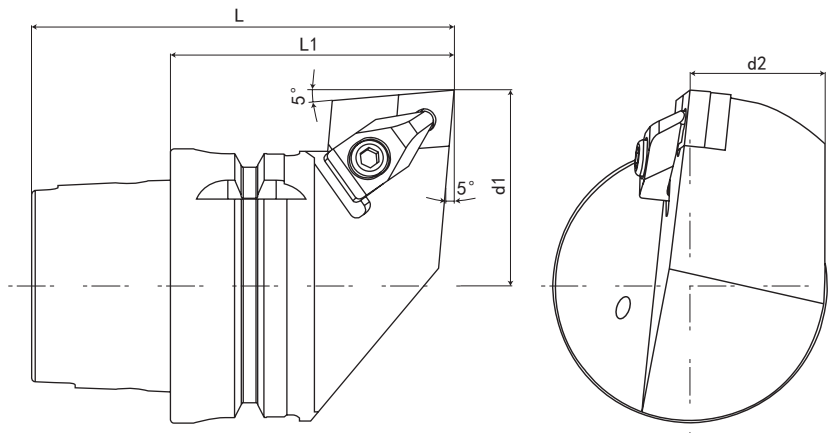

规格 Spec.	L	L1	d1	d2	刀片 Insert	重量 (KGS) Weight
HSK-T63-DCLNR-45065-12	97	65	45	31	CN..1204	1.26
HSK-T63-DCLNL-45065-12	97	65	45	31	CN..1204	1.26

配件表 Accessories

刀片 Insert	垫片 Shim	垫片螺丝 Shim Screw	扳手 Wrench	扭力值 (N.m) Torque	压板 Clamp	压板螺丝 Clamp Screw	压板扳手 Clamp Wrench	扭力值 (N.m) Torque
CN..1204	CMS432	MLP46L-A	PL2.5	5.0	MC620	MS630	PL3	5.0

DDJN 外径车刀

DDJN EXTERNAL TURNING TOOL

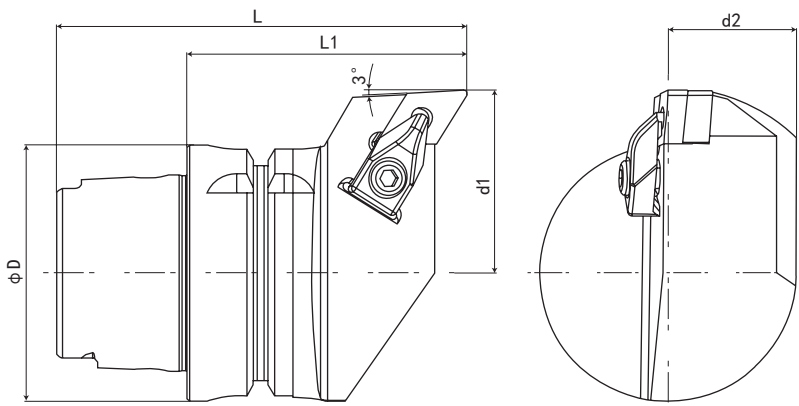

规格 Spec.	L	L1	d1	d2	刀片 Insert	重量 (KGS) Weight
HSK-T63-DDJNR-45075-15	107	75	45	31	DN..1504	1.38
HSK-T63-DDJNL-45075-15	107	75	45	31	DN..1504	1.38

配件表 Accessories

刀片 Insert	垫片 Shim	垫片螺丝 Shim Screw	扳手 Wrench	扭力值 (N.m) Torque	压板 Clamp	压板螺丝 Clamp Screw	压板扳手 Clamp Wrench	扭力值 (N.m) Torque
DN..1504	DMS442	MLP46L-A	PL2.5	5.0	MC622	MS630	PL3	5.0



HSK-T车铣复合刀座
HSK-T turning and milling tool holder

DTJN 外径车刀

DTJN EXTERNAL TURNING TOOL

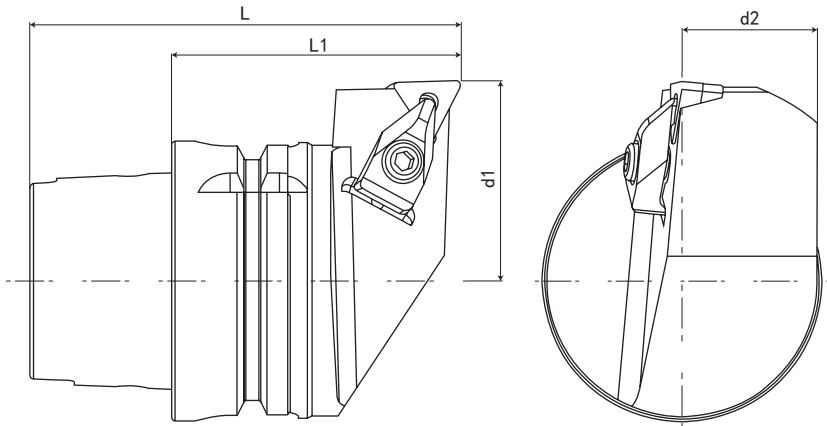

规格 Spec.	L	L1	d1	d2	刀片 Insert	重量 (KGS) Weight
HSK-T63-DTJNR-45065-16	97	65	45	31	TN..1604	1.27
HSK-T63-DTJNL-45065-16	97	65	45	31	TN..1604	1.27

配件表 Accessories

刀片 Insert	垫片 Shim	垫片螺丝 Shim Screw	扳手 Wrench	扭力值 (N.m) Torque	压板 Clamp	压板螺丝 Clamp Screw	压板扳手 Clamp Wrench	扭力值 (N.m) Torque
TN..1604	TMS322	MLP34L-A	PL2	3.0	MC620	MS630	PL3	5.0

HSK T 车铣复合刀座
HSK T Turning Milling Tool Holder

DWLN 外径车刀

MWLN EXTERNAL TURNING TOOL

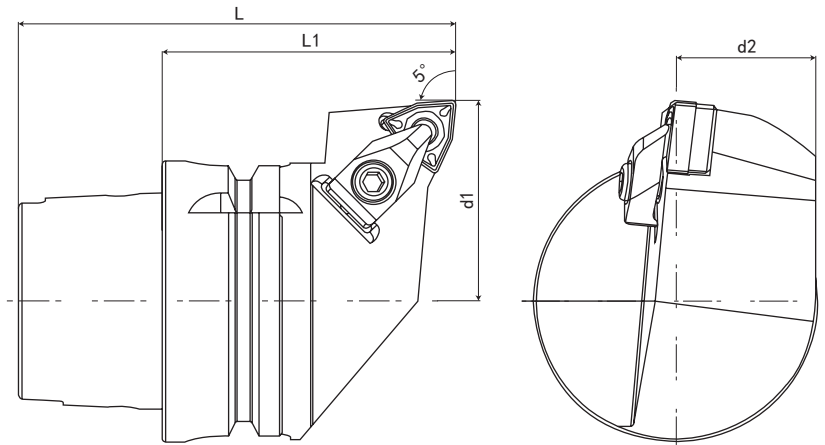

规格 Spec.	L	L1	d1	d2	刀片 Insert	重量 (KGS) Weight
HSK-T63-DWLN-45065-08	97	65	45	31	WN..0804	1.22
HSK-T63-DWLN-45065-08	97	65	45	31	WN..0804	1.22

配件表 Accessories

刀片 Insert	垫片 Shim	垫片螺丝 Shim Screw	扳手 Wrench	扭力值 (N.m) Torque	压板 Clamp	压板螺丝 Clamp Screw	压板扳手 Clamp Wrench	扭力值 (N.m) Torque
WN..0804	WMS432	MLP46L-A	PL2.5	5.0	MC620	MS630	PL3	5.0

数控刀柄系列 CNC TOOL SYSTEMS

DVLN 外径车刀

MVLN EXTERNAL TURNING TOOL

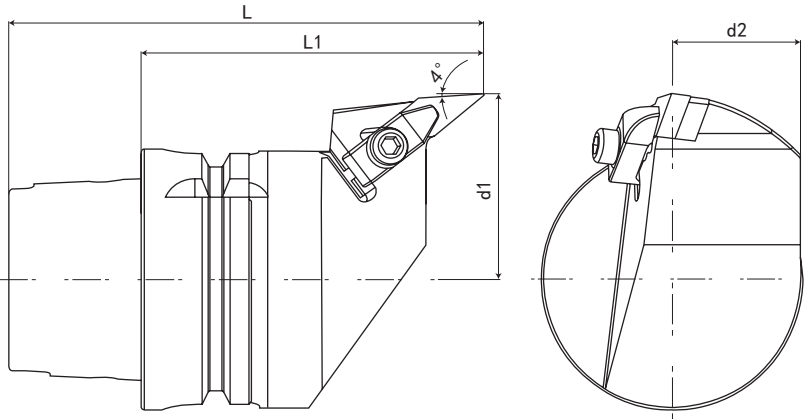

规格 Spec.	L	L1	d1	d2	刀片 Insert	重量 (KGS) Weight
HSK-T63-DVLNR-45075-16	107	75	45	31	VN..1604	1.30
HSK-T63-DVLNL-45075-16	107	75	45	31	VN..1604	1.30

配件表 Accessories

刀片 Insert	垫片 Shim	垫片螺丝 Shim Screw	扳手 Wrench	扭力值 (N.m) Torque	压板 Clamp	压板螺丝 Clamp Screw	压板扳手 Clamp Wrench	扭力值 (N.m) Torque
VN..1604	VMS322	MLP34L-A	PL2	3.0	MC622	MS630	PL3	5.0

DCMN 外径车刀

DCMN EXTERNAL TURNING TOOL

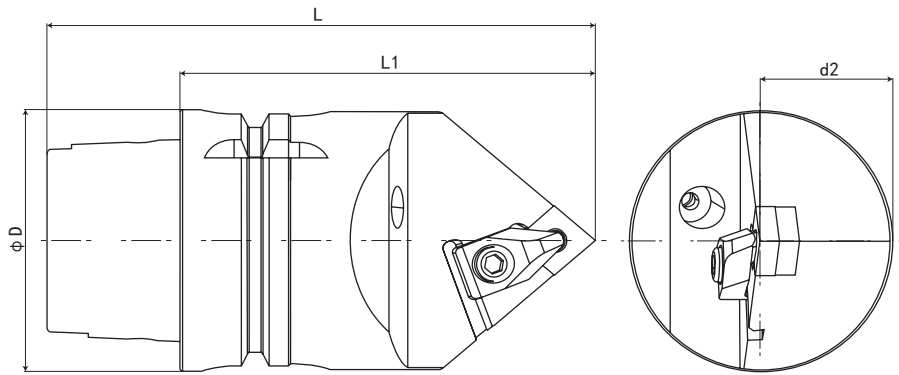

规格 Spec.	L	L1	刀片 Insert	重量 (KGS) Weight
HSK-T63-DCMNN-00100-12	132	100	CN..1204	1.68
HSK-T63-DCMNN-00140-12	172	140	CN..1204	1.68

配件表 Accessories

刀片 Insert	垫片 Shim	垫片螺丝 Shim Screw	扳手 Wrench	扭力值 (N.m) Torque	压板 Clamp	压板螺丝 Clamp Screw	压板扳手 Clamp Wrench	扭力值 (N.m) Torque
CN..1204	CMS432	MLP46L-A	PL2.5	5.0	MC620	MS620	PL3	5.0



HSK 车铣复合刀座
HSK Turning and Milling Tool Holder

DDNN 外径车刀

DDNN EXTERNAL TURNING TOOL

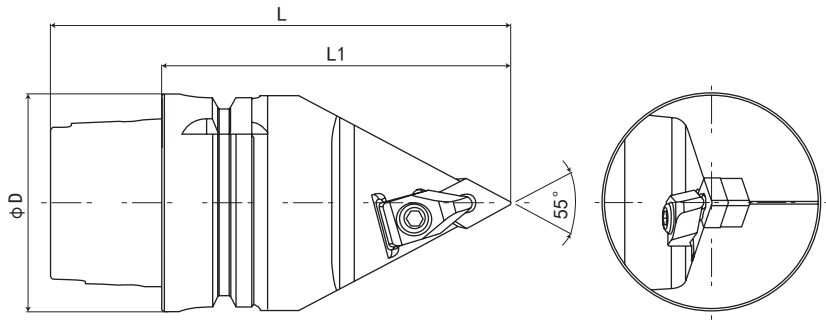

规格 Spec.	L	L1	D	刀片 Insert	重量 (KGS) Weight
HSK-T63-DDNNN-00100-15	132	100	63	DN..1504	1.55
HSK-T63-DDNNN-00140-15	172	140	63	DN..1504	1.55

配件表 Accessories

刀片 Insert	垫片 Shim	垫片螺丝 Shim Screw	扳手 Wrench	扭力值 (N.m) Torque	压板 Clamp	压板螺丝 Clamp Screw	压板扳手 Clamp Wrench	扭力值 (N.m) Torque
DN..1504	DMS442	MLP46L-A	PL2.5	5.0	MC622	MS625	PL3	5.0

DTEN 外径车刀

DTEN EXTERNAL TURNING TOOL

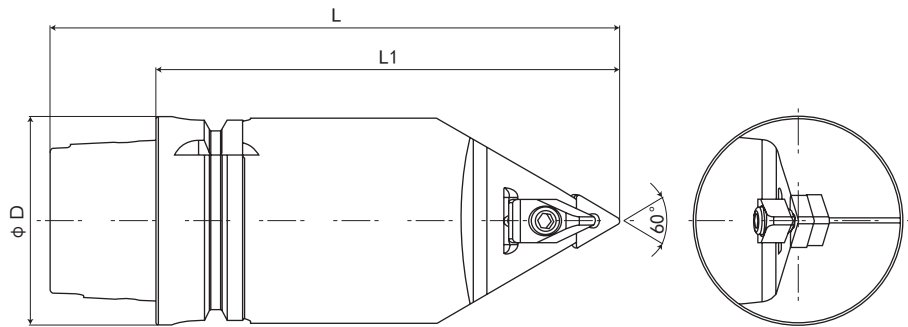

规格 Spec.	L	L1	D	刀片 Insert	重量 (KGS) Weight
HSK-T63-DTENN-00100-16	132	100	63	TN..1604	1.62
HSK-T63-DTENN-00140-16	172	140	63	TN..1604	1.62

配件表 Accessories

刀片 Insert	垫片 Shim	垫片螺丝 Shim Screw	扳手 Wrench	扭力值 (N.m) Torque	压板 Clamp	压板螺丝 Clamp Screw	压板扳手 Clamp Wrench	扭力值 (N.m) Torque
TN..1604	TMS322	MLP34L-A	PL2	3.0	MC620	MS630	PL3	5.0

数控刀柄系列 CNC TOOL SYSTEMS

DWMN 外径车刀

DWMN EXTERNAL TURNING TOOL

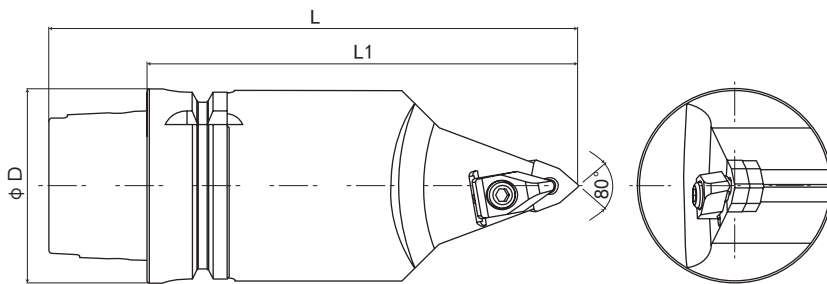

规格 Spec.	L	L1	D	刀片 Insert	重量 (KGS) Weight
HSK-T63-DWMNN-00100-08	132	100	63	WN..0804	1.48
HSK-T63-DWMNN-00140-08	172	140	63	WN..0804	1.48

配件表 Accessories

刀片 Insert	垫片 Shim	垫片螺丝 Shim Screw	扳手 Wrench	扭力值 (N.m) Torque	压板 Clamp	压板螺丝 Clamp Screw	压板扳手 Clamp Wrench	扭力值 (N.m) Torque
WN..0804	WMS432	MLP46L-A	PL2.5	5.0	MC620	MS630	PL3	5.0

DVNN 外径车刀

DVNN EXTERNAL TURNING TOOL

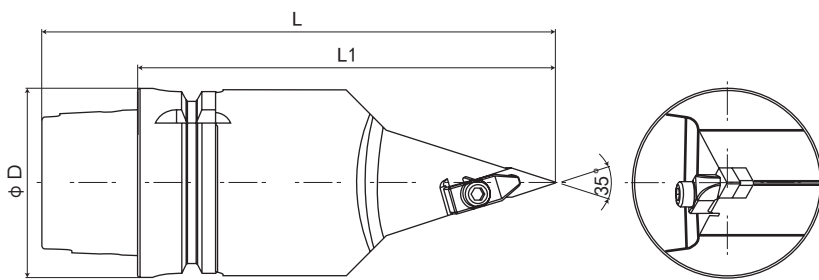

规格 Spec.	L	L1	D	刀片 Insert	重量 (KGS) Weight
HSK-T63-DVNN-00100-16	132	100	63	VN..1604	1.40
HSK-T63-DVNN-00140-16	172	140	63	VN..1604	1.40

配件表 Accessories

刀片 Insert	垫片 Shim	垫片螺丝 Shim Screw	扳手 Wrench	扭力值 (N.m) Torque	压板 Clamp	压板螺丝 Clamp Screw	压板扳手 Clamp Wrench	扭力值 (N.m) Torque
VN..1604	VMS322	MLP34L-A	PL2	3.0	MC622	MS630	PL3	5.0

HSK 车床复合刀座
HSK Turning and Milling Tool Holder