

# 攻丝夹头系列

TAPPING CHUCK SERIES



# 攻丝夹头系列

TAPPING CHUCK SERIES

# 攻丝夹头系列 TAPPING CHUCK SERIES

## 攻牙本体系列 TAPPING CHUCK SYSTEM

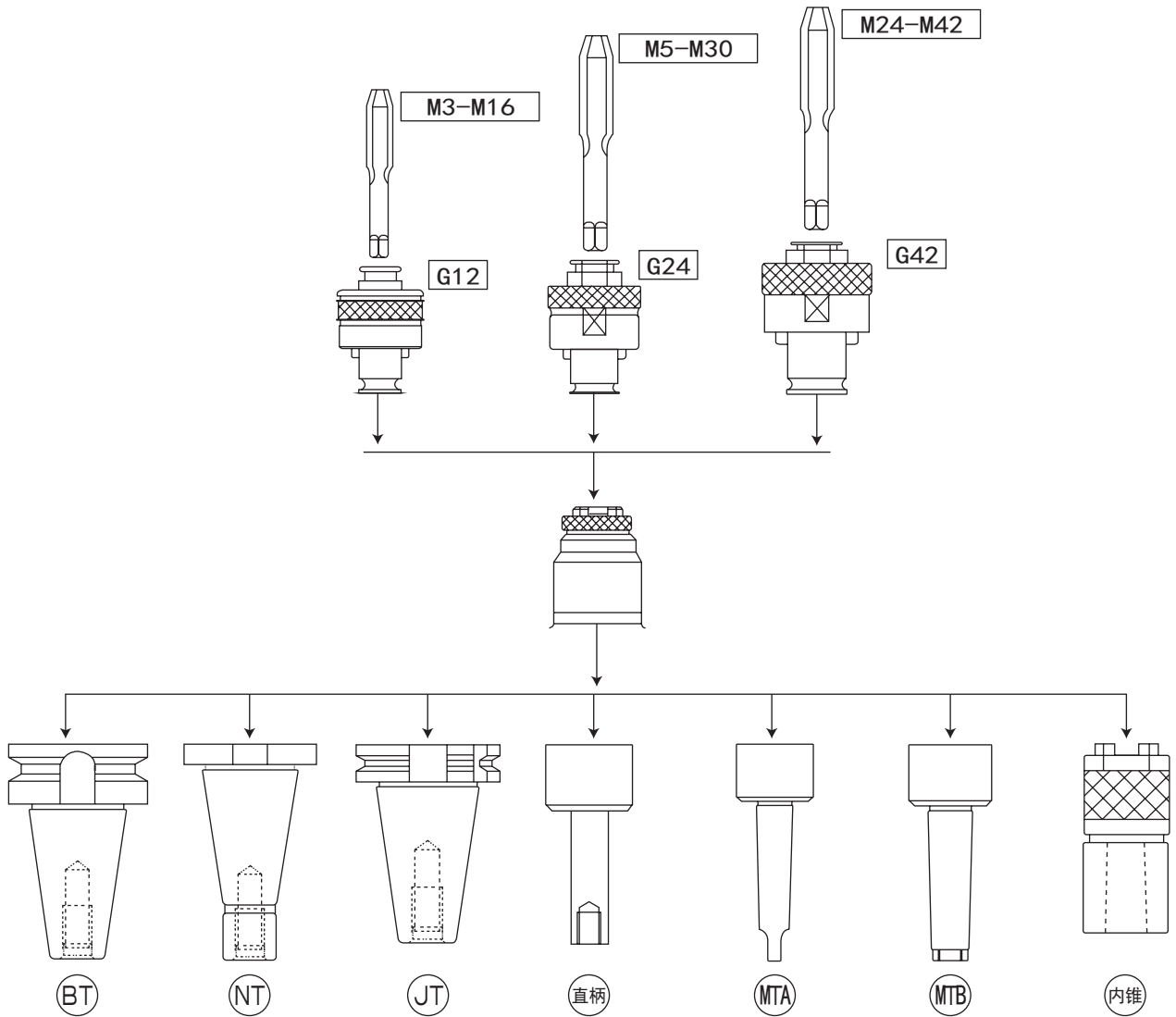

攻丝夹头系列  
TAPPING CHUCK SERIES

## 限制螺孔深度设定方案及操作注意事项 TAP SETTING AND INSTRUCTION MANUAL

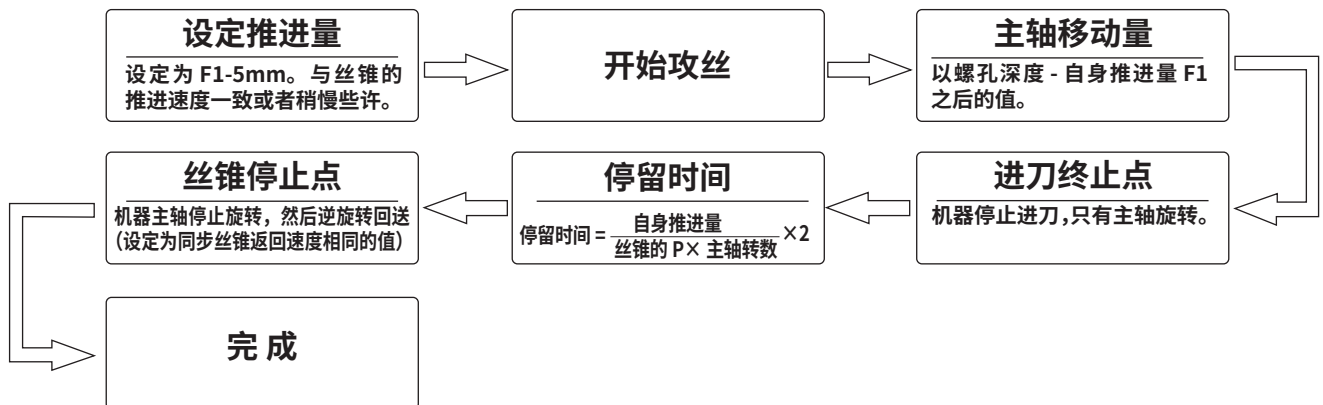

### 注意事项:

#### 1、攻丝刀柄伸缩机构

攻丝刀柄本身自己自带伸缩的伸缩机构。这是防止双螺丝及丝锥的牙距与机械进给能圆滑的同步进行。必须在伸缩量的范围内使用。

##### ①伸长过量

超过伸长界限时，黑色标记会出来，请加快机床进给量。

##### ②压缩过量

机床进给比丝锥进刀快，压缩机构动作，请减少机床进给量。

2、底孔较小时（难切削材质等加工时，底孔径不够的现象较多），扭矩保护机构，使丝锥空转。这种情况下，不要调整扭矩（ZK 攻丝套筒的场合），请扩大底孔。

3、盲孔攻丝时，程序的 Z 轴指令偏深时，主轴回转停止时，孔底在回转力的作用下，因碰到底部，无法伸长。反转时，在出口时无法恢复的原长，丝锥容易碰盲孔口部。这种情况下，请加深下底部或减浅指令值。

4、Z 型攻丝刀柄的场合，机器的固定进给，Z 点反转开始 Z 上升，攻丝刀柄是在缩短的状态 Z 轴上升，孔口容易与丝锥碰到，这种情况下，Z 点进入停顿，攻丝刀柄在伸长的状下，随 Z 轴一起上升。

5、攻丝刀柄和攻丝套筒的修理费，人为损坏及保修期后，修复及检测均需收费（基本费用）。

### Remarks:

#### 1、TENSION AND COMPRESSION TAPER HOLDER

Tension and compression function can prove screw and tap tooth space moving sleekly and synchronously with machine . It should be used in the scope of designed tension and compression.

##### ① Over tension

The black mark can be seen at this time. Please up the working speed of axis.

##### ② Over compression

Reduce the moving speed of axis.

2、In case of small hole in tapping model, torque protection function makes taps idling. Don't adjust the torque instead of large one.

3、When blind hole tapping, Z axis programmed with slant depth and under the gyroscopic force and touch the bottom part, in case of reversal, orifice can be easily touched. Pls deepen the hole or reduce programmed Z axis data instruction.

4、When Z system tapping chuck in use, in other case of orifice touched, please stop the Z point, tapping chuck run up with Z axis in the state of elongation.

5、In case of artificial damage or after warranty period, The cost for evaluating and remanding should be charged.

## 常见直槽高速丝锥的切削扭矩参考值

### HIGH SEED AND STRAIGHT SLOT CUTTING TORQUE REFERENCE

丝锥尺寸	最小攻丝 扭矩 N·m	最大攻丝 扭矩 N·m	丝锥折断扭矩 (低强度) N·m	丝锥折断扭矩 (高强度) N·m	所需功率 KW	攻丝夹头的调整值 (正常) N·m	攻丝夹头的调整值 (最小) N·m	攻丝夹头的调整值 (最大) N·m
M5	2.26	3.39	4.52	4.78	0.247	2.82	2.26	4.52
M6	3.39	4.78	5.65	11.3	0.373	4.52	3.39	6.78
M8	4.52	9.04	8.48	17	0.373	6.78	5.65	11.3
M10	11.3	22.6	20.3	28.3	0.56	14.7	12.4	24.9
M12	11.3	22.6	20.3	33.9	0.746	22.6	20.3	33.9
M14	22.6	67.8	56.5	90.4	0.93	39.5	39.5	73.4
M16	28.3	67.8	72.5	123	0.56	51	51	73.4
M20	56.5	113	113	170	1.3	73.4	73.4	107

# 攻丝夹头系列 TAPPING CHUCK SERIES

丝锥标准形式

TAP SCREW BLANK SYSTEM

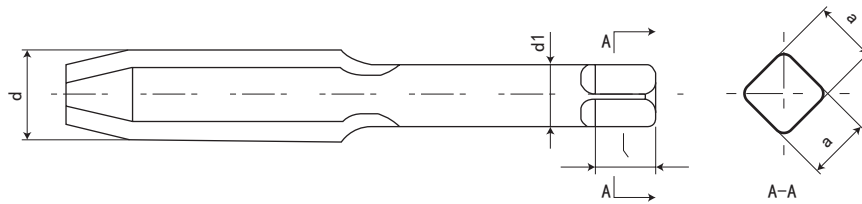

公制	美制	英制	JIS		ISO		DIN371		DIN376		英制工作 直径 d1
			直径 d1	四角 axa	直径 d1	四角 axa	直径 d1	四角 axa	直径 d1	四角 axa	
M3		W1/8	4	3.2	3.15	2.5	3.5	2.7	2.2		3.18
M4/M4.5		W5/32	5	4	4	3.15	4.5	3.4	2.8	2.1	3.97
M5/M5.5		W3/16	5.5	4.5	5	4	6	4.9	3.5	2.7	4.76
M6	U1/4	W1/4	6	4.5	6.3	5	6	4.9	4.5	3.4	6.35
	U5/16	W5/16	6.1	5.5							7.94
M8/M7			6.2	5	6.3	5	8	6.2	6	4.9	
M10/M9	U3/8	W3/8	7	5.5	8	6.3		8	7	5.5	9.52
M11	U7/16	W7/16	8	6							11.11
M12			8.5	6.5	9	7.1			9	7	
	U1/2	W1/2	9	7							12.7
M14/M15	U9/16	W9/16	10.5	8	11.2	9			11	9	14.28
	U5/8	W5/8	12	9							15.88
M16			12.5	10	12.5	10			12	9	
M17			13	10							
M18	U3/4	W3/4	14	11	14	11.2			14	11	19.05
M20			15	12	14	11.2			16	12	
M22	U7/8	W7/8	17	13	16	12.5			18	14.5	22.22
M24/M25			19	15	18	14			18	14.5	
M25/M26	U1	W1	20	15							25.4
M27			20	15	20	16			20	16	
M28			21	17							
	U1 1/8	W1 1/8	22	17							28.58
M30			23	17	20	16			22	18	
M32	U1 1/4	W1 1/4	24	19							31.75
M33			25	19	22.4	18					
M34/M35	U1 3/8	W1 3/8	26	21							34.93
M36			28	21	25	20					
M39/M40	U1 1/2	W1 1/2	30	23							38.1
M42		W1 5/8	32	26	28	22.4					41.28
M45	U1 3/4	W1 3/4	35	26							44.45
M48		W1 7/8	38	29	31.5	25					47.63

攻丝夹头系列  
TAPPING  
CHUCK SERIES



# BT-GT 扭力伸缩攻牙本体

# TENSION AND COMPRESSION TAPER HOLDER/BT-GT

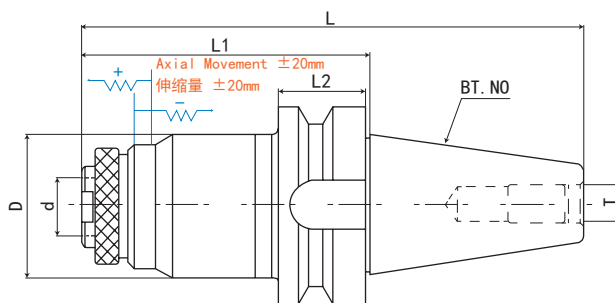

P.P13



P.129

型号 / 规格 Model	攻牙范围 Tapping range	D	d	L	L1	L2	T	夹头名称 Collet name
BT30-GT12-120L	M3-M16	46	19	168	120	20	M12	GT12
BT40-GT12-110L	M3-M16	46	19	175	110	25	M16	GT12
BT50-GT12-120L	M3-M16	46	19	222	120	35	M24	GT12
型号 / 规格 Model	攻牙范围 Tapping range	D	d	L	L1	L2	T	夹头名称 Collet name
BT30-GT24-120L	M5-M30	66	30	168	120	20	M12	GT24
BT40-GT24-130L	M5-M30	66	30	195	130	25	M16	GT24
BT50-GT24-130L	M5-M30	66	30	232	130	35	M24	GT24
型号 / 规格 Model	攻牙范围 Tapping range	D	d	L	L1	L2	T	夹头名称 Collet name
BT50-GT42-190L	M24-M42	95	45	292	190	35	M24	GT42

## 特点:

### 注:

- ◎ 本体规格: JIS MAS 403 BT
- ◎ 具有扭矩过载保护可防止丝锥断裂
- ◎ 具有浮动、伸缩、快换等功能
- ◎ 适合在 CNC 加工中心、数控铣床等机床设备
- ◎ 攻丝范围: M3-M42

## Features:

- ◎ Spindle conicity standard: JIS MAS 403 BT
- ◎ Torque overload protection protects screw blank from fracture.
- ◎ Have floating, quick change and torque protection functions.
- ◎ Used on lathes, borers and private plane machines and so on.
- ◎ Tapping range: M3-M42.

BT30 - GT - 12 - 120L

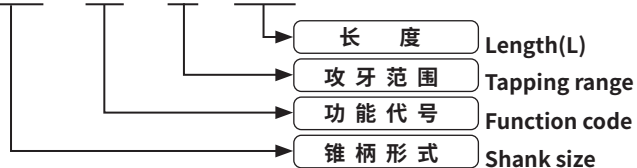

TAPPING  
CHUCK SERIES  
攻丝夹头系列

# 攻丝夹头系列 TAPPING CHUCK SERIES

## SK/DAT-GT 扭力伸缩攻牙本体

TENSION AND COMPRESSION TAPER HOLDER/SK/DAT-GT

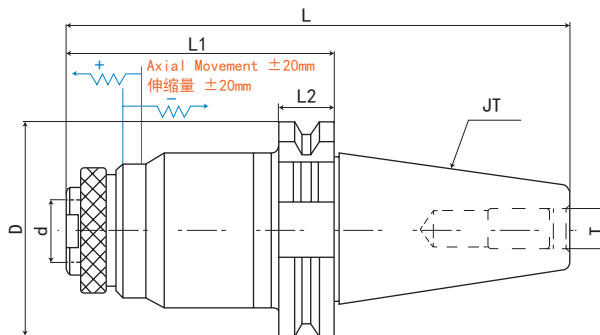

P.P13

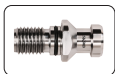

P.I24

型号 / 规格 Model	攻牙范围 Tapping range	D	d	L	L1	L2	T	夹头名称 Collet name
SK30-GT12-120L	M3-M16	46	19	168	120	16	M12	GT12
SK40-GT12-110L	M3-M16	46	19	175	110	16	M16	GT12
SK50-GT12-120L	M3-M16	46	19	222	120	16	M24	GT12
型号 / 规格 Model	攻牙范围 Tapping range	D	d	L	L1	L2	T	夹头名称 Collet name
SK30-GT24-120L	M5-M30	66	30	168	120	16	M12	GT24
SK40-GT24-130L	M5-M30	66	30	195	130	16	M16	GT24
SK50-GT24-130L	M5-M30	66	30	232	130	16	M24	GT24
型号 / 规格 Model	攻牙范围 Tapping range	D	d	L	L1	L2	T	夹头名称 Collet name
SK50-GT42-190L	M24-M42	95	45	292	190	16	M24	GT42

### 特点:

注:

- ◎ 本体规格: DIN69871-A 及 GB10944
- ◎ 具有扭矩过载保护可防止丝锥断裂
- ◎ 具有浮动、伸缩、快换等功能
- ◎ 适合在 CNC 加工中心、数控铣床等机床设备
- ◎ 攻丝范围: M3-M42

### Features:

- ◎ Spindle conicity standard: DIN69871AorGB10944
- ◎ Torque overload protection protects screw blank from fracture.
- ◎ Have floating, quick change and torque protection functions.
- ◎ Used on lathes, borers and private plane machines and so on.
- ◎ Tapping range:M3-M42.

SK30 - GT - 12 - 120L

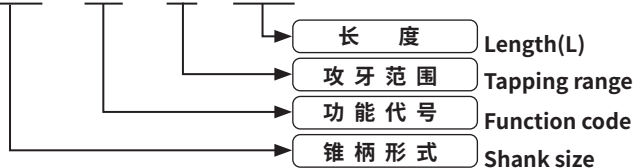

# NT-GT 扭力伸缩攻牙本体

# TENSION AND COMPRESSION TAPER HOLDER/NT-GT

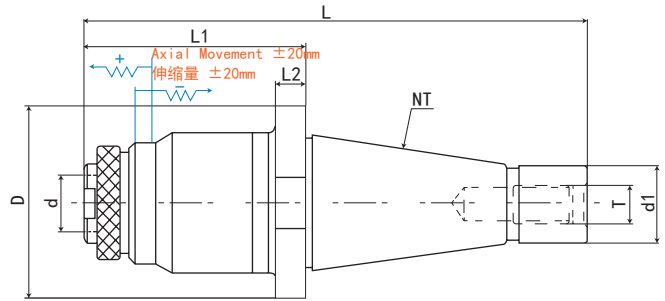

P.P13

型号 / 规格 Model	攻牙范围 Tapping range	D	d	L	L1	L2	T	夹头名称 Collet name
NT30-GT12-120L	M3-M16	46	19	188	120	9	M12	GT12
NT40-GT12-110L	M3-M16	46	19	203	110	9	M16	GT12
NT50-GT12-120L	M3-M16	46	19	247	120	12	M24	GT12
型号 / 规格 Model	攻牙范围 Tapping range	D	d	L	L1	L2	T	夹头名称 Collet name
NT30-GT24-120L	M5-M30	66	30	188	120	9	M12	GT24
NT40-GT24-130L	M5-M30	66	30	223	130	9	M16	
NT50-GT24-130L	M5-M30	66	30	257	130	12	M24	
型号 / 规格 Model	攻牙范围 Tapping range	D	d	L	L1	L2	T	夹头名称 Collet name
NT50-GT42-190L	M24-M42	95	45	317	190	12	M24	GT42

## 特点:

注:

- ◎ 本体规格: DIN2080
- ◎ 具有扭矩过载保护可防止丝锥断裂
- ◎ 具有浮动、伸缩、快换等功能
- ◎ 适合铣床、镗床、专机等机床设备
- ◎ 攻丝范围: M3-M42

## Features:

- ◎ Spindle conicity standard: DIN2080
- ◎ Torque overload protection protects screw blank from fracture.
- ◎ Have floating, quick change and torque protection functions.
- ◎ Used on lathes, borers and private plane machines and so on.
- ◎ Tapping range: M3-M42.

NT30 - GT - 12 - 120L

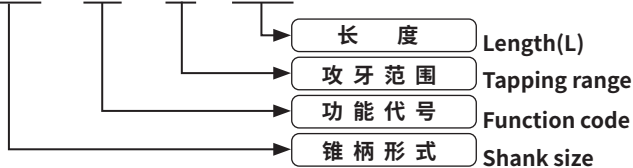

TAPPING  
CHUCK SERIES  
攻丝夹头系列

# 攻丝夹头系列 TAPPING CHUCK SERIES

## C-GT 直柄扭力伸缩攻牙刀柄

TENSION AND COMPRESSION TAPER HOLDER/STRAIGHT SHANK

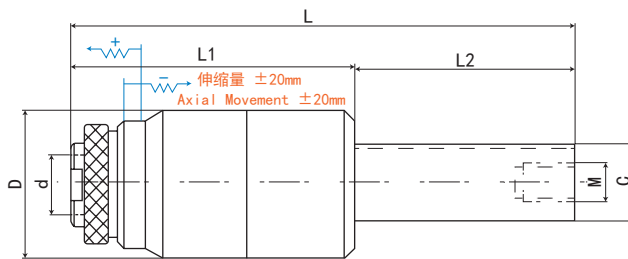

P.P13

型号 / 规格 Model	攻牙范围 Tapping range	D	d	L	L1	L2	M	夹头名称 Collet name
C16-GT12-110L	M3-M16	46	19	160/210	110	50/100	M12*1.75P	GT12
C20-GT12-110L	M3-M16	46	19	160/210	110	50/100	M12*1.75P	GT12
C25-GT12-110L	M3-M16	46	19	160/210	110	50/100	M12*1.75P	GT12
C32-GT12-110L	M3-M16	46	19	210/260	110	100/150	M12*1.75P	GT12
型号 / 规格 Model	攻牙范围 Tapping range	D	d	L	L1	L2	M	夹头名称 Collet name
C20-GT24-120L	M5-M30	66	30	170/220	120	50/100	M12*1.75P	GT24
C25-GT24-120L	M5-M30	66	30	170/220	120	50/100	M12*1.75P	GT24
C32-GT24-120L	M5-M30	66	30	220/270	120	100/150	M12*1.75P	GT24

### 特点:

注:

- ◎具有扭矩过载保护可防止丝锥断裂
- ◎具有浮动、伸缩、快换等功能
- ◎适合各种夹头加长和各种设备攻牙
- ◎攻丝范围: M3-M30

### Features:

- ◎ Torque overload protection protects screw blank from fracture.
- ◎ Have floating, quick change and torque protection functions.
- ◎ Used on drill machines, tapping machines, borers, lathes and so on for tapping.
- ◎ Tapping range: M3-M30.

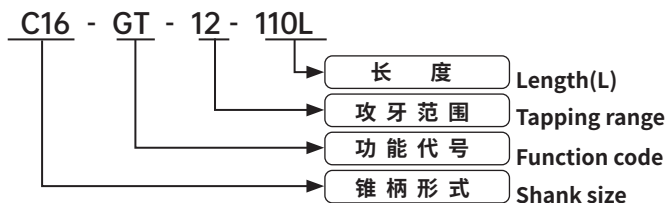

攻丝夹头系列 TAPPING CHUCK SERIES



# MTA-GT 扭力伸缩攻牙本体

# TENSION AND COMPRESSION TAPER HOLDER/MTA-GT

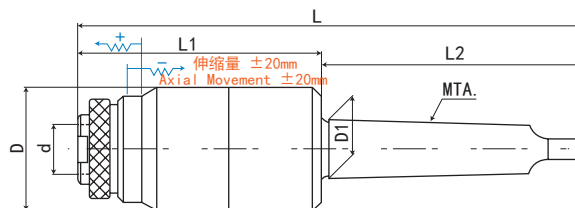

P.P13

型号 / 规格 Model	攻牙范围 Tapping range	D	D1	d	L	L1	L2	夹头名称 Collet name
MTA2-GT12-110L	M3-M16	46	17.780	19	194	110	84	GT12
MTA3-GT12-110L	M3-M16	46	23.825	19	209	110	99	GT12
MTA4-GT12-110L	M3-M16	46	31.267	19	234	110	124	GT12
MTA5-GT12-110L	M3-M16	46	44.399	19	266	110	156	GT12
型号 / 规格 Model	攻牙范围 Tapping range	D	D1	d	L	L1	L2	夹头名称 Collet name
MTA2-GT24-120L	M5-M30	66	17.780	30	204	120	84	GT24
MTA3-GT24-120L	M5-M30	66	23.825	30	219	120	99	GT24
MTA4-GT24-120L	M5-M30	66	31.267	30	244	120	124	GT24
MTA5-GT24-120L	M5-M30	66	44.399	30	276	120	156	GT24
型号 / 规格 Model	攻牙范围 Tapping range	D	D1	d	L	L1	L2	夹头名称 Collet name
MTA5-GT42-190L	M24-M42	95	44.399	45	346	190	156	GT42
MTA6-GT42-190L	M24-M42	95	63.348	45	408	190	218	GT42
公制 80-GT42-190L	M24-M42	95	80.00	45	418	190	228	GT42

## 特点:

注:

- ◎ 本体规格: 莫氏带扁尾锥柄
- ◎ 具有扭矩过载保护可防止丝锥断裂
- ◎ 具有浮动、伸缩、快换等功能
- ◎ 适合钻床、攻牙机、车床、铣床等机床设备
- ◎ 攻丝范围: M3-M42

## Features:

- ◎ Spindle conicity standard: MORSE TAPER(Tongue Type)
- ◎ Torque overload protection protects screw blank from fracture.
- ◎ Have floating, quick change and torque protection functions.
- ◎ Used on drill machines, tapping machines, borers, lathes and so on for tapping.
- ◎ Tapping range: M3-M42.

MTA2 - GT - 12 - 110L

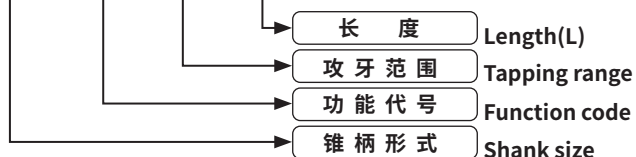

TAPPING  
CHUCK SERIES  
攻丝夹头系列



# 攻丝夹头系列 TAPPING CHUCK SERIES

## MTB-GT 扭力伸缩攻牙本体

## TENSION AND COMPRESSION TAPER HOLDER/MTB-GT

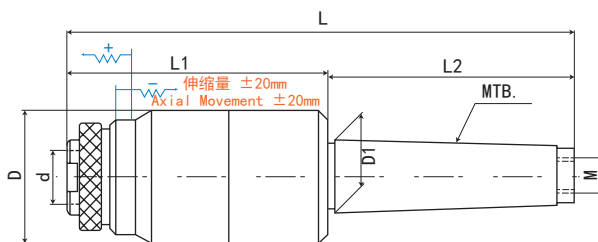

P.P13

型号 / 规格 Model	攻牙范围 Tapping range	D	D1	d	L	L1	L2	M	夹头名称 Collet name
MTB2-GT12-110L	M3-M16	46	17.780	19	178	110	68	M10*1.5P	GT12
MTB3-GT12-110L	M3-M16	46	23.825	19	195	110	85	M12/1.75P	GT12
MTB4-GT12-110L	M3-M16	46	31.267	19	218	110	108	M16*2.0P	GT12
MTB5-GT12-110L	M3-M16	46	44.399	19	246	110	136	M20*2.5P	GT12
型号 / 规格 Model	攻牙范围 Tapping range	D	D1	d	L	L1	L2	M	夹头名称 Collet name
MTB2-GT24-120L	M5-M30	66	17.780	30	188	120	68	M10*1.5P	GT24
MTB3-GT24-120L	M5-M30	66	23.825	30	205	120	85	M12/1.75P	GT24
MTB4-GT24-120L	M5-M30	66	31.267	30	228	120	108	M16*2.0P	GT24
MTB5-GT24-120L	M5-M30	66	44.399	30	256	120	136	M20*2.5P	GT24

### 特点:

#### 注:

- ◎ 本体规格: 莫氏后拉式锥柄
- ◎ 具有扭矩过载保护可防止丝锥断裂
- ◎ 具有浮动、伸缩、快换等功能
- ◎ 适合钻床、攻牙机、车床、铣床等机床设备
- ◎ 攻丝范围: M3-M42

### Features:

- ◎ Spindle conicity standard: MORSE TAPER(Drawing Thread Type)
- ◎ Torque overload protection protects screw blank from fracture.
- ◎ Have floating, quick change and torque protection functions.
- ◎ Used on drill machines, tapping machines, borers, lathes and so on for tapping.
- ◎ Tapping range: M3-M42.

MTB2 - GT - 12 - 110L

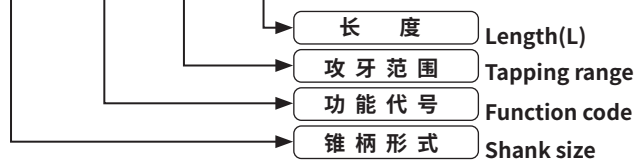

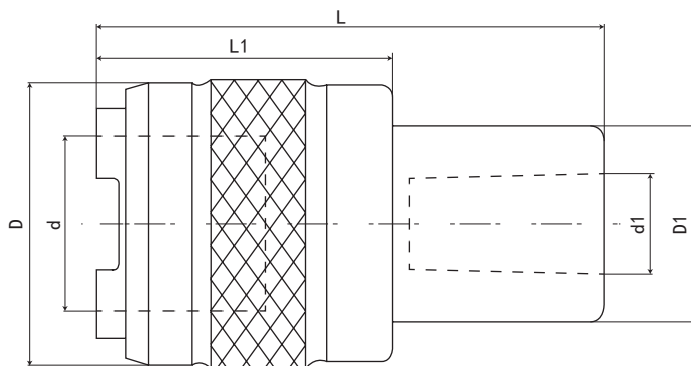

P. P13

型号 / 规格 Model	攻牙范围 Tapping range	D	D1	d	d1	L	L1	夹头名称 Collet name
B12-GT12	M3-M16	35	29	19	12.065	60	33	GT12
B16-GT12	M3-M16	35	29	19	15.733	64	33	GT12
B18-GT12	M3-M16	35	29	19	17.780	73	33	GT12
型号 / 规格 Model	攻牙范围 Tapping range	D	D1	d	d1	L	L1	夹头名称 Collet name
B16-GT24	M5-M30	51	34	30	15.733	78	57	GT24
B18-GT24	M5-M30	51	34	30	17.780	84	53	GT24
B22-GT24	M5-M30	51	38	30	21.793	93	53	GT24
型号 / 规格 Model	攻牙范围 Tapping range	D	D1	d	d1	L	L1	夹头名称 Collet name
B18-GT42	M24-M42	78	50	45	17.780	110	70	GT42
B22-GT42	M24-M42	78	50	45	21.793	110	70	GT42
B28-GT42	M24-M42	78	50	45	28.00	110	70	GT42

攻丝夹头系列  
TAPPING CHUCK SERIES

## 特点:

注:

- ◎具有扭矩过载保护可防止丝锥断裂
- ◎具有浮动、伸缩、快换等功能
- ◎适合台钻、攻丝机、车床、专机等机床设备
- ◎攻丝范围: M3-M42

## Features:

- ◎ Torque overload protection protects screw blank from fracture.
- ◎ Have floating, quick change and torque protection functions.
- ◎ Used on drill machines, tapping machines, borers, lathes and so on for tapping.
- ◎ Tapping range: M3-M42.

B12 - GT - 12

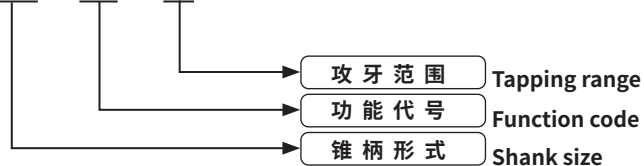

# 攻丝夹头系列 TAPPING CHUCK SERIES

## GT- 直孔键槽伸缩扭力攻丝刀柄

## TENSION AND COMPRESSION TAPER HOLDER GT

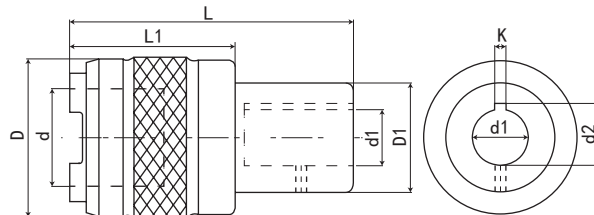

P.P13

型号 / 规格 Model	攻牙范围 Tapping range	D	D1	d	d1	d2	K	L	L1	夹头名称 Collet name
φ14-GT12	M3-M16	34	29	19	14	16.5	5	60	33	GT12
φ16-GT12	M3-M16	34	29	19	16	18	5	70	33	GT12
φ18-GT12	M3-M16	34	29	19	18	20	5	70	33	GT12
型号 / 规格 Model	攻牙范围 Tapping range	D	D1	d	L	d2	K	L	L1	夹头名称 Collet name
φ20-GT24	M5-M30	51	34	30	20	23.5	6	90	57	GT24
φ22-GT24	M5-M30	51	34	30	22	25.5	6	90	57	GT24
型号 / 规格 Model	攻牙范围 Tapping range	D	D1	d	d1	d2	K	L	L1	夹头名称 Collet name
φ20-GT42	M24-M42	78	50	45	20	23.5	6	113	70	GT42
φ22-GT42	M24-M42	78	50	45	22	25.5	6	113	70	GT42
φ25-GT42	M24-M42	78	50	45	25	28	6	113	70	GT42

### 特点:

注:

- ◎具有扭矩过载保护可防止丝锥断裂
- ◎具有浮动、伸缩、快换等功能
- ◎适合台钻、攻丝机、车床、专机等机床设备
- ◎攻丝范围: M3-M42

### Features:

- ◎ Torque overload protection protects screw blank from fracture.
- ◎ Have floating, quick change and torque protection functions.
- ◎ Used on drill machines, tapping machines, borers, lathes and so on for tapping.
- ◎ Tapping range: M3-M42.

## GT 转换套

## GT TAP CHUCK REDUCER

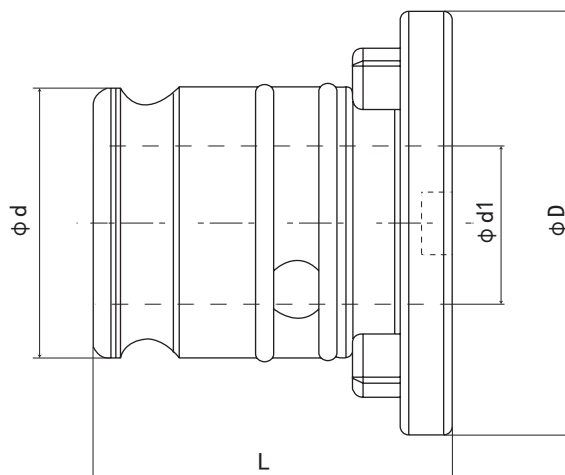

型号 / 规格 Model	D	d	d1	L	夹头名称 Collet name
GT42-GT24	64	45	30	55	GT24
GT24-GT12	44	30	19	36	GT12
TC820-GT12	48	31	19	41	GT12



GT12

GT24



GT42

攻牙本体与攻丝筒夹连接操作方法 QUICK CHANGE PROTECT TAP COLLET-G SYSTEM

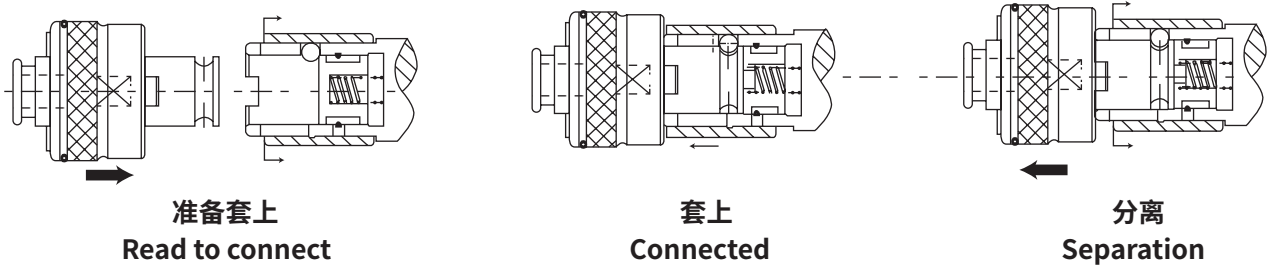

攻牙筒夹与刀具连接操作方法 SCREW TAP AND COLLET CONNECTING

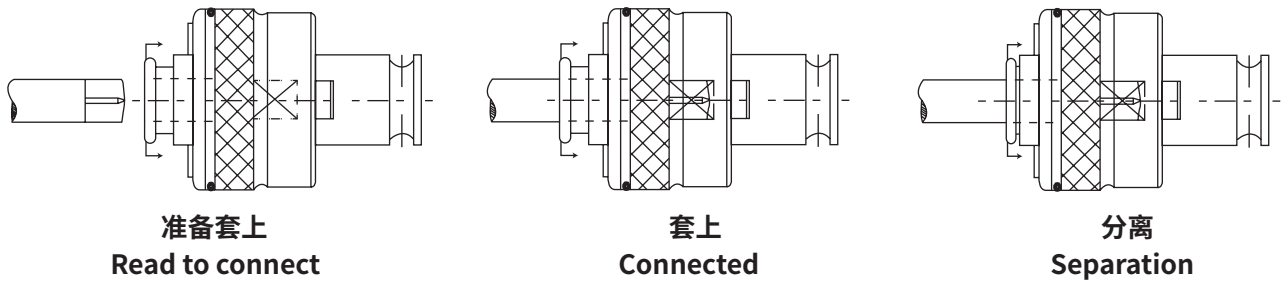

TAPPING CHUCK SERIES 攻丝夹头系列

可调整安全固定钮操作方法 SAFETY FIXED BOTTOM ADJUSTING

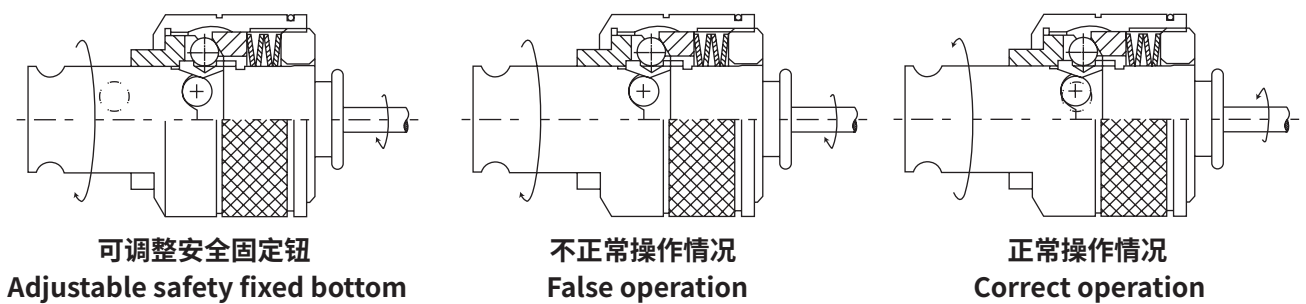

先取下卡环，扭力调整把手顺时针旋转调整所需扭力，再上卡环即可。



图 1

先取下卡环，扭力调整把手逆时针旋转调整所需扭力，再上卡环即可。



图 2

# 攻丝夹头系列 TAPPING CHUCK SERIES

## GT12 过载保护攻丝夹头 (国标) OVERLOAD PROTECTION TAP COLLET-GT12 SYSTEM (ISO)

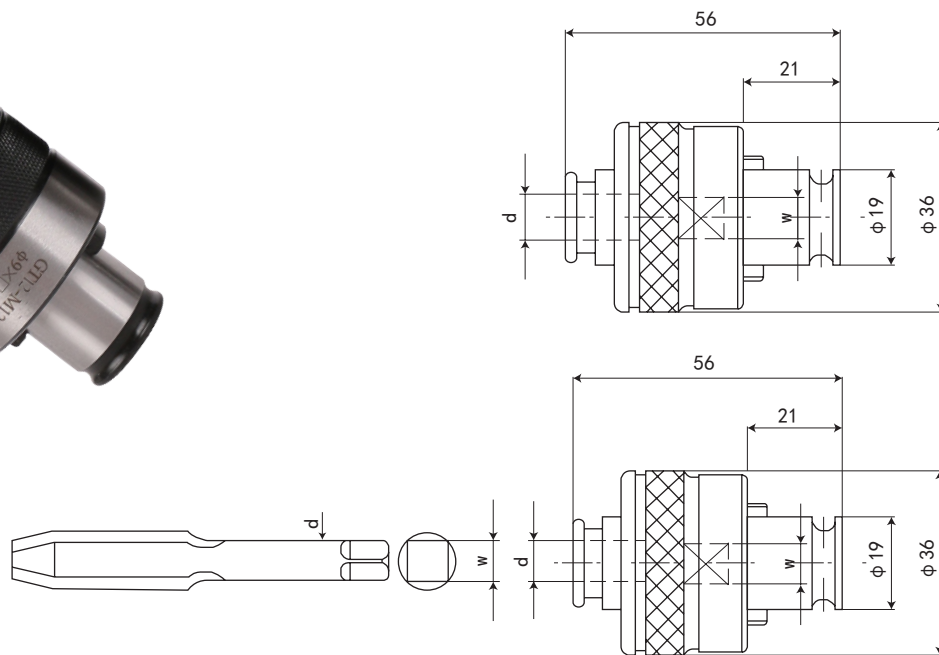

规格 (国标) Model(ISO)	夹持丝锥 (ISO 国标)	丝锥柄径 d	丝锥方 W
ISO-GT12-M3	M3	3.15	2.5X2.5
ISO-GT12-M4	M4	4	3.15X3.15
ISO-GT12-M5	M5	5	4X4
ISO-GT12-M6	M6	6.3	5X5
ISO-GT12-M8	M8	6.3	5X5
ISO-GT12-M10	M10	8	6.3X6.3
ISO-GT12-M12	M12	9	7.1X7.1
ISO-GT12-M14	M14	11.2	9X9
ISO-GT12-M16	M16	12.5	10X10

## GT12 过载保护攻丝夹头 (英制 / 日标) OVERLOAD PROTECTION TAP COLLET-GT12 SYSTEM (INCH/JIS)

规格 (英制 / 日标) Model(INCH/JIS)	夹持丝锥 (JIS 日标)	夹持丝锥 (INCH 英制)	丝锥柄径 d	丝锥方 W
JIS-GT12-M3	M3	1/8	4	3.2X3.2
JIS-GT12-M4	M4	5/32	5	4X4
JIS-GT12-M5	M5	3/16	5.5	4.5X4.5
JIS-GT12-M6	M6	1/4	6	4.5X4.5
JIS-GT12-M8	M8	-	6.2	5X5
JIS-GT12-M10	M10	3/8	7	5.5X5.5
JIS-GT12-M12	M12	-	8.5	6.5X6.5
JIS-GT12-M14	M14	9/16	10.5	8X8
JIS-GT12-M16	M16	-	12.5	10X10

### 特点:

#### 注:

- ◎本品具有扭矩过载保护功能、高精度、高感度和使用寿命长。
- ◎扭矩的变动反应灵敏，可根据各种不同材质而设定相应的扭矩。
- ◎适用于各种攻牙机和电动攻牙机、气动攻牙机。
- ◎目前已与众多攻牙机厂配套使用。

### Features:

- ◎ High precision, long tool-life with torque protection function.
- ◎ Torsion reflect sensitive and changes according to various material to set up corresponding torque.
- ◎ Used for kinds of tapping machine including electric tapping machine and pneumatic tapping machine.
- ◎ At present, many tapping machine factories have been used with this type.



## GT24 过载保护攻丝夹头 (国标)

OVERLOAD PROTECTION TAP COLLET-GT24 SYSTEM (ISO)

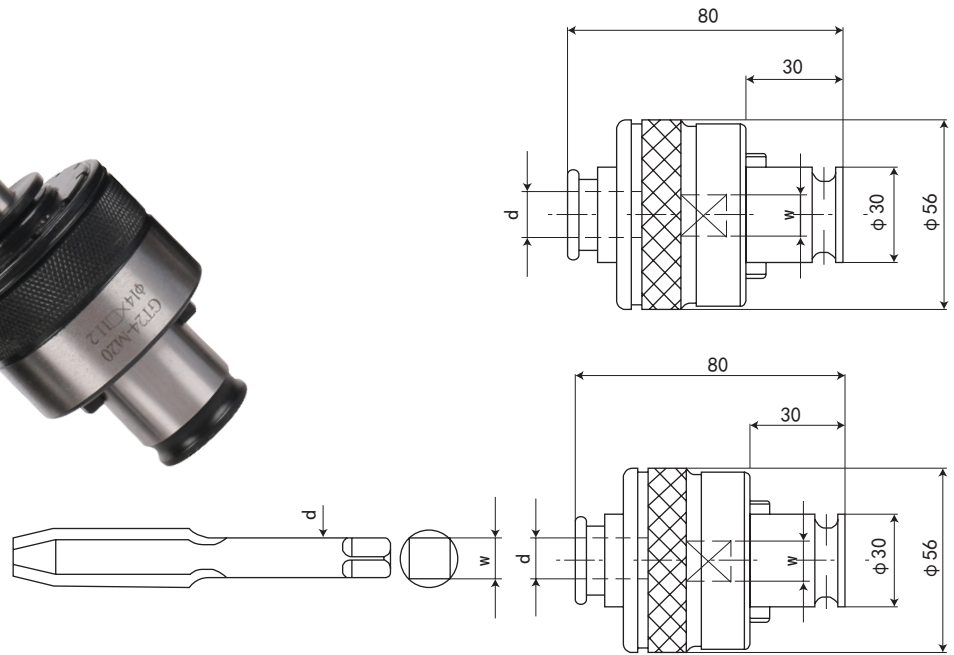

规格 (国标) Model(ISO)	夹持丝锥 (ISO 国标)	丝锥柄径 d	丝锥方 W
ISO-GT24-M5	M5	5	4X4
ISO-GT24-M6	M6	6.3	5X5
ISO-GT24-M8	M8	6.3	5X5
ISO-GT24-M10	M10	8	6.3X6.3
ISO-GT24-M12	M12	9	7.1X7.1
ISO-GT24-M14	M14	11.2	9X9
ISO-GT24-M16	M16	12.5	10X10
ISO-GT24-M18	M18	14	11.2X11.2
ISO-GT24-M20	M20	14	11.2X11.2
ISO-GT24-M22	M22	16	12.5X12.5
ISO-GT24-M24	M24	18	14X14
ISO-GT24-M27	M27	20	16X16
ISO-GT24-M30	M30	20	16X16

TAPPING  
CHUCK SERIES  
攻丝夹头系列

## GT24 过载保护攻丝夹头 (英制 / 日标)

OVERLOAD PROTECTION TAP COLLET-GT24 SYSTEM (INCH/JIS)

规格 (英制 / 日标) Model(INCH/JIS)	夹持丝锥 (JIS 日标)	夹持丝锥 (INCH 英制)	丝锥柄径 d	丝锥方 W
JIS-GT24-M5	M5	3/16	5.5	4.5X4.5
JIS-GT24-M6	M6	1/4	6	4.5X4.5
JIS-GT24-M8	M8	-	6.2	5X5
JIS-GT24-M10	M10	3/8	7	5.5X5.5
JIS-GT24-M12	M12	-	8.5	6.5X6.5
JIS-GT24-M14	M14	9/16	10.5	8X8
JIS-GT24-M16	M16	-	12.5	10X10
JIS-GT24-M18	M18	3/4	14	11X11
JIS-GT24-M20	M20	-	15	12X12
JIS-GT24-M22	M22	7/8	17	13X13
JIS-GT24-M24	M24	-	19	15X15
JIS-GT24-M27	M27	-	20	15X15
JIS-GT24-M30	M30	-	23	17X17

### 特点:

注:

- ◎本品具有扭矩过载保护功能、高精度、高感度和使用寿命长。
- ◎扭矩的变动反应灵敏, 可根据各种不同材质而设定相应的扭矩。
- ◎适用于各种攻牙机器和电动攻牙机、气动攻牙机。
- ◎目前已与众多攻牙机厂配套使用。

### Features:

- ◎ High precision, long tool-life with torque protection function.
- ◎ Torsion reflect sensitive and changes according to various material to set up corresponding torque.
- ◎ Used for kinds of tapping machine including electric tapping machine and pneumatic tapping machine.
- ◎ At present, many tapping machine factories have been used with this type.

# 攻丝夹头系列 TAPPING CHUCK SERIES

## GT42 过载保护攻丝夹头 (国标) OVERLOAD PROTECTION TAP COLLET-GT42 SYSTEM (ISO)

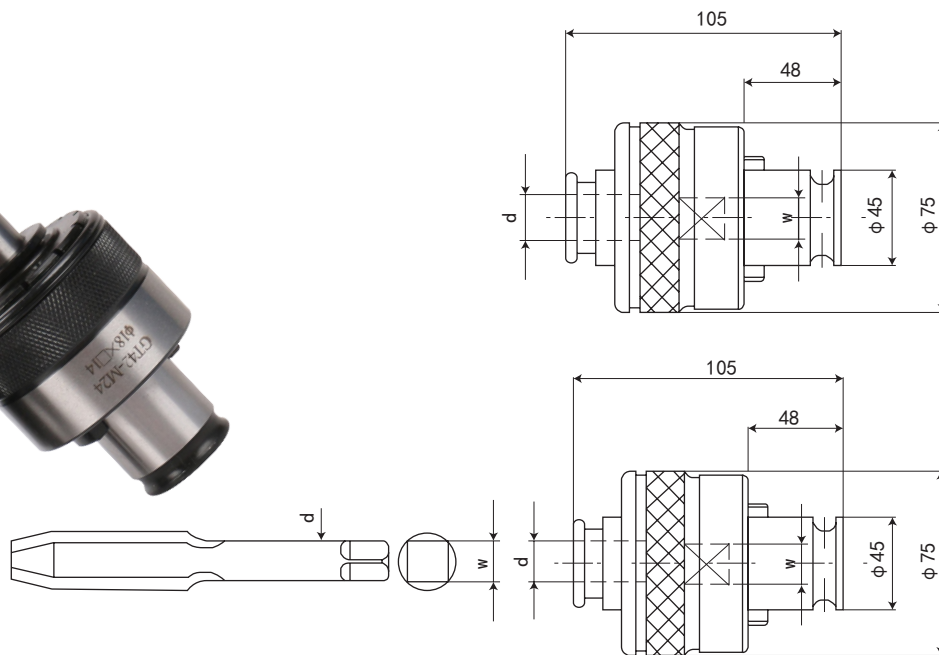

规格 (国标) Model(ISO)	夹持丝锥 (ISO 国标)	丝锥柄径 d	丝锥方 W
ISO-GT42-M24	M24	18	14X14
ISO-GT42-M27	M27	20	16X16
ISO-GT42-M30	M30	20	16X16
ISO-GT42-M33	M33	22.4	18X18
ISO-GT42-M36	M36	25	20X20
ISO-GT42-M39	M39	28	22.4X22.4
ISO-GT42-M42	M42	28	22.4X22.4
ISO-GT42-M45	M45	31.5	25X25
ISO-GT42-M48	M48	31.5	25X25

## GT42 过载保护攻丝夹头 (日标) OVERLOAD PROTECTION TAP COLLET-GT42 SYSTEM (JIS)

规格 (英制 / 日标) Model(INCH/JIS)	夹持丝锥 (JIS 日标)	丝锥柄径 d	丝锥方 W
JIS-GT42-M24	M24	19	15X15
JIS-GT42-M27	M27	20	15X15
JIS-GT42-M30	M30	23	17X17
JIS-GT42-M33	M33	25	19X19
JIS-GT42-M36	M36	28	21X21
JIS-GT42-M39	M39	30	23X23
JIS-GT42-M42	M42	32	26X26
JIS-GT42-M45	M45	35	26X26
JIS-GT42-M48	M48	38	29X29

### 特点:

注:

- ◎本品具有扭矩过载保护功能、高精度、高感度和使用寿命长。
- ◎扭矩的变动反应灵敏,可根据各种不同材质而设定相应的扭矩。
- ◎适用于各种攻牙机器和电动攻牙机、气动攻牙机。
- ◎目前已与众多攻牙机厂配套使用。

### Features:

- ◎ High precision, long tool-life with torque protection function.
- ◎ Torsion reflect sensitive and changes according to various material to set up corresponding torque.
- ◎ Used for kinds of tapping machine including electric tapping machine and pneumatic tapping machine.
- ◎ At present, many tapping machine factories have been using with this type.

# BT-TER-A 刚性伸缩加长攻牙刀柄

RIGID TENSION AND COMPRESSION TAPER HOLDER/BT-TER-A

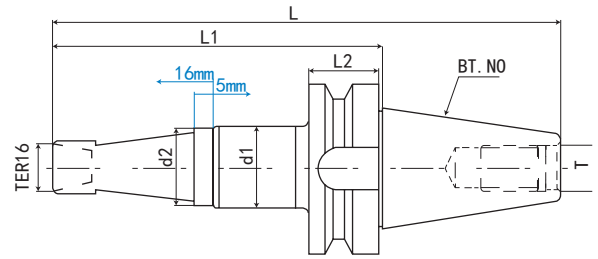

P.131



P.106



P.133



P.129



P.P34

规格 / 型号 Model	攻牙范围 Tapping range	L	L1	L2	d1	d2	T	筒夹名称 Collet name
BT40-TER16-A-180L	M2-M12	247.4	180	25	29.5	21.5	M16	TER16
BT30-TER16-A-170L	M2-M12	218.4	170	20	29.5	21.5	M12	TER16
C20-TER16-A-180L	M2-M12	280	180	34	29.5	21.5	M12	TER16
C25-TER16-A-180L	M2-M12	280	180	34	29.5	21.5	M12	TER16

## 特点:

注:

- ◎ 本体规格: JIS MAS 403 BT
- ◎ 刚性功能确保加工中心主轴转动同进给精确同步, 使用专用基础刀柄。
- ◎ 刚性攻牙刀柄可使用 ER 筒夹代替, 作为夹持钻头、铰刀和铣刀工具刀柄。
- ◎ 采用刚性攻牙本体, 使用时, 螺帽请勿过度锁紧, 以免造成损坏, ER 扳手为另购品。
- ◎ 具有深孔攻牙和深层台阶面攻牙功能。

## Features:

- ◎ Spindle Conicity Standard: JIS MAS 403 BT
- ◎ Rigid function ensures machining center spindle rotate in synchronized precise, While MTB holder in use.
- ◎ Can be replaced by ER collet for gripping cutting tool, Drill bit, and draw bolt and so on.
- ◎ Don't lock excessively of the clamping nut in case of damage. Wrench not included.
- ◎ Don't lock excessively of the clamping nut in case of damage. Wrench not included.

BT40 - TER - 16 - 180L

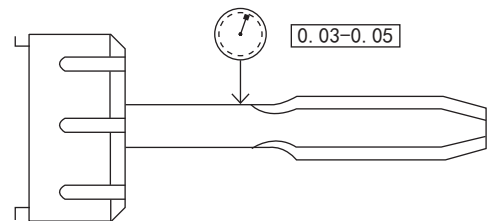
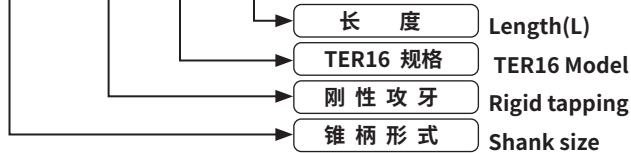

TAPPING  
CHUCK SERIES  
攻丝夹头系列

# 攻丝夹头系列 TAPPING CHUCK SERIES

## BT-TER-A 刚性伸缩攻牙刀柄

RIGID TENSION AND COMPRESSION TAPER HOLDER/BT-TER-A

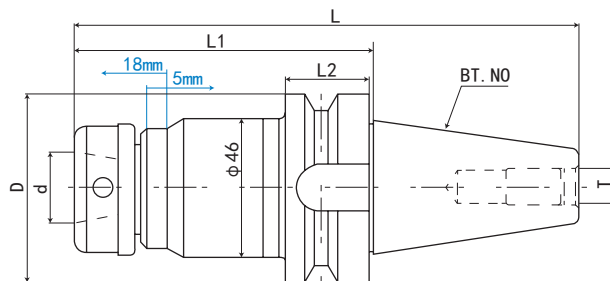

P.131



P.106



P.133



P.129



P. P34

规格 / 型号 Model	攻牙范围 Tapping range	D	d	L	L1	L2	T	筒夹名称 Collet name
BT30-TER16-A-105L	M2-M12	46	16	153.4	105	20	M12	TER16
BT30-TER20-A-105L	M2-M16	46	20	153.4	105	20	M12	TER20
BT30-TER25-A-105L	M2-M22	46	25	153.4	105	20	M12	TER25
BT30-TER32-A-110L	M2-M30	46	32	158.4	110	20	M12	TER32
规格 / 型号 Model	攻牙范围 Tapping range	D	d	L	L1	L2	T	筒夹名称 Collet name
BT40-TER16-A-105L	M2-M12	63	16	170.4	105	25	M16	TER16
BT40-TER20-A-105L	M2-M16	63	20	170.4	105	25	M16	TER20
BT40-TER25-A-105L	M2-M22	63	25	170.4	105	25	M16	TER25
BT40-TER32-A-110L	M2-M30	63	32	175.4	110	25	M16	TER32
BT40-TER40-A-110L	M2-M36	63	40	175.4	110	25	M16	TER40
规格 / 型号 Model	攻牙范围 Tapping range	D	d	L	L1	L2	T	筒夹名称 Collet name
BT50-TER16-A-110L	M2-M12	100	16	211.8	110	35	M24	TER16
BT50-TER20-A-110L	M2-M16	100	20	211.8	110	35	M24	TER20
BT50-TER25-A-120L	M2-M22	100	25	221.8	120	35	M24	TER25
BT50-TER32-A-120L	M2-M30	100	32	221.8	120	35	M24	TER32
BT50-TER40-A-130L	M2-M36	100	40	231.8	130	35	M24	TER40

攻丝夹头系列  
TAPPING  
CHUCK SERIES

### 特点:

注:

- ◎ 本体规格: JIS MAS 403 BT
- ◎ 刚性功能确保加工中心主轴转动同进给精确同步, 使用专用基础刀柄。
- ◎ 刚性攻牙刀柄可使用 ER 筒夹代替, 作为夹持钻头、铰刀和铣刀工具刀柄。
- ◎ 采用刚性攻牙本体, 使用时, 螺帽请勿过度锁紧, 以免造成损坏, ER 扳手为另购品。

### Features:

- ◎ Spindle Conicity Standard: JIS MAS 403 BT
- ◎ Rigid function ensures machining center spindle rotate in synchronized precise, While MTB holder in use.
- ◎ Can be replaced by ER collet for gripping cutting tool, Drill bit, and draw bolt and so on.
- ◎ Don't lock excessively of the clamping nut in case of damage. Wrench not included.

BT30 - TER - 16 - 105L

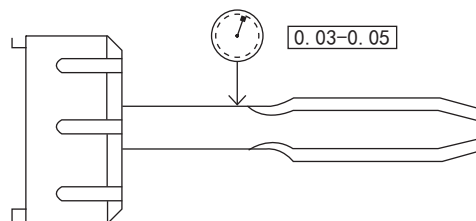

# SK/DAT-TER-A 刚性伸缩攻牙刀柄

RIGID TENSION AND COMPRESSION TAPER HOLDER-SK/DAT

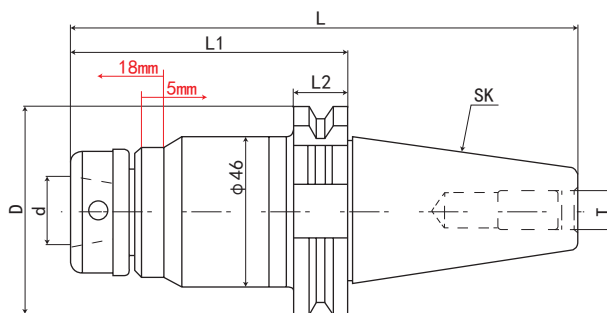

P. I31



P. I06



P. I33



P. I24



P. P34

规格 / 型号 Model	攻牙范围 Tapping range	D	d	L	L1	L2	T	筒夹名称 Collet name
SK40-TER16-A-100L	M2-M12	63.55	16	168.4	100	15.9	M16	TER16
SK40-TER20-A-100L	M2-M16	63.55	20	168.4	100	15.9	M16	TER20
SK40-TER25-A-100L	M2-M22	63.55	25	168.4	100	15.9	M16	TER25
SK40-TER32-A-100L	M2-M30	63.55	32	168.4	100	15.9	M16	TER32
SK40-TER40-A-110L	M2-M36	63.55	40	178.4	110	15.9	M16	TER40
规格 / 型号 Model	攻牙范围 Tapping range	D	d	L	L1	L2	T	筒夹名称 Collet name
SK50-TER16-A-100L	M2-M12	97.5	16	201.75	100	15.9	M24	TER16
SK50-TER20-A-100L	M2-M16	97.5	20	201.75	100	15.9	M24	TER20
SK50-TER25-A-100L	M2-M22	97.5	25	201.75	100	15.9	M24	TER25
SK50-TER32-A-100L	M2-M30	97.5	32	201.75	100	15.9	M24	TER32
SK50-TER40-A-110L	M2-M36	97.5	40	211.75	110	15.9	M24	TER40

## 特点:

注:

- ◎ 本体规格: DIN69871-A 及 GB10944
- ◎ 刚性功能确保加工中心主轴转动同进给精确同步, 使用专用基础刀柄。
- ◎ 刚性攻牙刀柄可使用 ER 筒夹代替, 作为夹持钻头、铰刀和铣刀工具刀柄。
- ◎ 采用刚性攻牙本体, 使用时, 螺帽请勿过度锁紧, 以免造成损坏, ER 扳手为另购品。

## Features:

- ◎ Spindle Conicity Standard: DIN69871A or GB10944
- ◎ Rigid function ensures machining center spindle rotate in synchronized precise, While MTB holder in use.
- ◎ Can be replaced by ER collet for gripping cutting tool, Drill bit, and draw bolt and so on.
- ◎ Don't lock excessively of the clamping nut in case of damage. Wrench not included.

TAPPING CHUCK SERIES 攻丝夹头系列

JT40 - TER - 16 - 100L

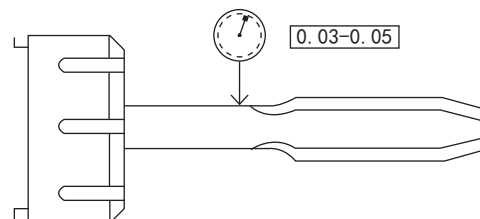
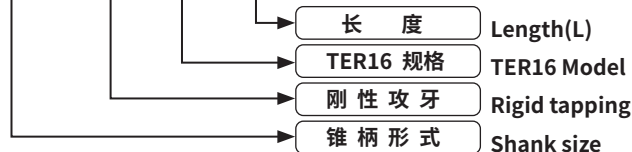



# 攻丝夹头系列 TAPPING CHUCK SERIES

## NT-TER-A 刚性伸缩攻牙刀柄

RIGID TENSION AND COMPRESSION TAPER HOLDER/NT-TER-A

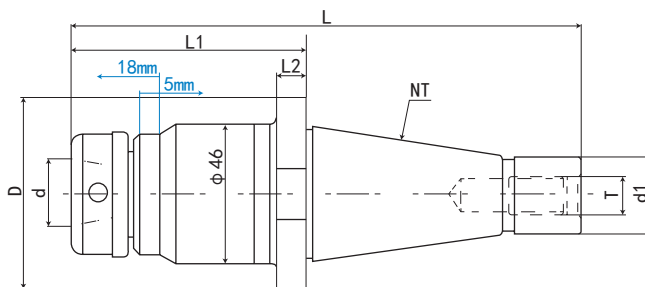

P.131



P.106



P.133



P.P34

规格 / 型号 Model	攻牙范围 Tapping range	D	d	d1	L	L1	L2	T	筒夹名称 Collet name
NT40-TER16-A-100L	M2-M12	63	16	25.3	193.4	100	10	M16	TER16
NT40-TER20-A-100L	M2-M16	63	20	25.3	193.4	100	10	M16	TER20
NT40-TER25-A-100L	M2-M22	63	25	25.3	193.4	100	10	M16	TER25
NT40-TER32-A-100L	M2-M30	63	32	25.3	193.4	100	10	M16	TER32
NT40-TER40-A-110L	M2-M36	63	40	25.3	203.4	110	10	M16	TER40
规格 / 型号 Model	攻牙范围 Tapping range	D	d	d1	L	L1	L2	T	筒夹名称 Collet name
NT50-TER16-A-100L	M2-M12	100	16	39.6	226.8	100	12	M24	TER16
NT50-TER20-A-100L	M2-M16	100	20	39.6	226.8	100	12	M24	TER20
NT50-TER25-A-100L	M2-M22	100	25	39.6	226.8	100	12	M24	TER25
NT50-TER32-A-100L	M2-M30	100	32	39.6	226.8	100	12	M24	TER32
NT50-TER40-A-110L	M2-M36	100	40	39.6	236.8	110	12	M24	TER40

### 特点:

注:

- ◎ 本体规格: DIN2080/GB3837
- ◎ 刚性功能确保加工中心主轴转动同进给精确同步, 使用专用基础刀柄。
- ◎ 刚性攻牙刀柄可使用 ER 筒夹代替, 作为夹持钻头、铰刀和铣刀工具刀柄。
- ◎ 采用刚性攻牙本体, 使用时, 螺帽请勿过度锁紧, 以免造成损坏, ER 扳手为另购品。

### Features:

- ◎ Spindle Conicity Standard: DIN2080 or GB3837
- ◎ Rigid function ensures machining center spindle rotate in synchronized precise, While MTB holder in use.
- ◎ Can be replaced by ER collet for gripping cutting tool, Drill bit, and draw bolt and so on.
- ◎ Don't lock excessively of the clamping nut in case of damage. Wrench not included.

NT40 - TER - 16 - 100L

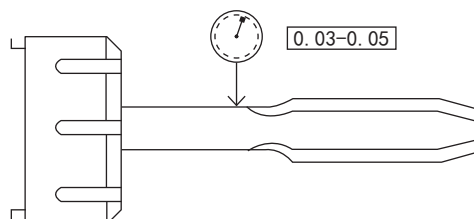
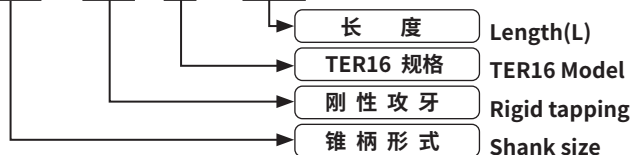

# C-TER-A 直柄刚性伸缩攻牙刀柄

## STRAIGHT SHANK RIGID TAPER HOLDER C-TER-A

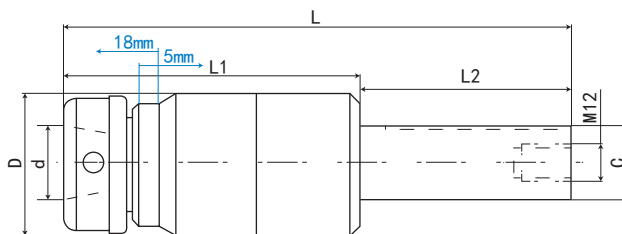

P.131



P.106



P.133



P.P34

规格 / 型号 Model	攻牙范围 Tapping range	D	d	L	L1	L2	C	筒夹名称 Collet name
C20-60/100-TER16-A-100L	M2-M12	46	16	160/200	100	60/100	20	TER16
C20-60/100-TER20-A-100L	M2-M16	46	20	160/200	100	60/100	20	TER20
C20-60/100-TER25-A-100L	M2-M22	46	25	160/200	100	60/100	20	TER25
C20-60/100-TER32-A-110L	M2-M30	46	32	170/210	110	60/100	20	TER32
规格 / 型号 Model	攻牙范围 Tapping range	D	d	L	L1	L2	D1	筒夹名称 Collet name
C25-60/100-TER16-A-100L	M2-M12	46	16	160/200	100	60/100	25	TER16
C25-60/100-TER20-A-100L	M2-M16	46	20	160/200	100	60/100	25	TER20
C25-60/100-TER25-A-100L	M2-M22	46	25	160/200	100	60/100	25	TER25
C25-60/100-TER32-A-110L	M2-M30	46	32	170/210	110	60/100	25	TER32
规格 / 型号 Model	攻牙范围 Tapping range	D	d	L	L1	L2	D1	筒夹名称 Collet name
C32-60/100-TER16-A-100L	M2-M12	46	16	160/200	100	60/100	32	TER16
C32-60/100-TER20-A-100L	M2-M16	46	20	160/200	100	60/100	32	TER20
C32-60/100-TER25-A-100L	M2-M22	46	25	160/200	100	60/100	32	TER25
C32-60/100-TER32-A-110	M2-M30	46	32	170/210	110	60/100	32	TER32

### 特点:

注:

- ◎ 刚性功能确保加工中心主轴转动同进给精确同步，使用专用基础刀柄。
- ◎ 刚性攻牙刀柄可使用 ER 筒夹代替，作为夹持钻头、铰刀和铣刀工具刀柄。
- ◎ 采用刚性攻牙本体，使用时，螺帽请勿过度锁紧，以免造成损坏，ER 扳手为另购品。

### Features:

- ◎ Rigid function ensures machining center spindle rotate in synchronized precise, While MTB holder in use.
- ◎ Can be replaced by ER collet for gripping cutting tool, Drill bit, and draw bolt and so on.
- ◎ Don't lock excessively of the clamping nut in case of damage. Wrench not included.

C20 - 50/100 - TER - 16 - 100L

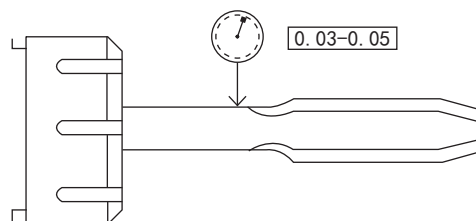
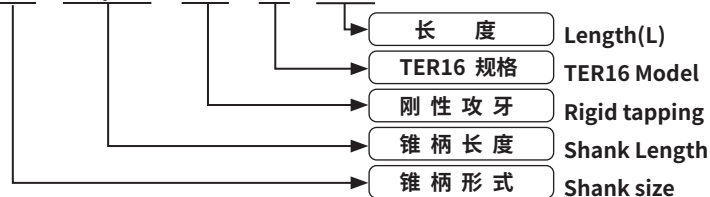

TAPPING  
CHUCK SERIES  
攻丝夹头系列

# 攻丝夹头系列 TAPPING CHUCK SERIES

## MTA-TER-A 莫氏扁尾刚性伸缩攻牙刀柄

MORSE RIGID TENSION AND COMPRESSION TAPER HOLDER (MTA)

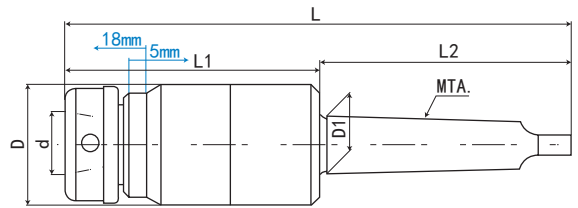

P.131

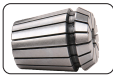

P.106



P.133



P.P34

规格 / 型号 Model	攻牙范围 Tapping range	D	d	L	L1	L2	D1	筒夹名称 Collet name
MTA2-TER16-A-100L	M2-M12	46	16	184	100	84	17.780	TER16
MTA2-TER20-A-100L	M2-M16	46	20	184	100	84	17.780	TER20
MTA2-TER25-A-100L	M2-M22	46	25	184	100	84	17.780	TER25
规格 / 型号 Model	攻牙范围 Tapping range	D	d	L	L1	L2	D1	筒夹名称 Collet name
MTA3-TER16-A-100L	M2-M12	46	16	199	100	99	23.825	TER16
MTA3-TER20-A-100L	M2-M16	46	20	199	100	99	23.825	TER20
MTA3-TER25-A-100L	M2-M22	46	25	199	100	99	23.825	TER25
MTA3-TER32-A-100L	M2-M30	46	32	199	100	99	23.825	TER32
规格 / 型号 Model	攻牙范围 Tapping range	D	d	L	L1	L2	D1	筒夹名称 Collet name
MTA4-TER16-A-100L	M2-M12	46	16	224	100	124	31.267	TER16
MTA4-TER20-A-100L	M2-M16	46	20	224	100	124	31.267	TER20
MTA4-TER25-A-100L	M2-M22	46	25	224	100	124	31.267	TER25
MTA4-TER32-A-100L	M2-M30	46	32	224	100	124	31.267	TER32
规格 / 型号 Model	攻牙范围 Tapping range	D	d	L	L1	L2	D1	筒夹名称 Collet name
MTA5-TER32-A-100L	M2-M30	46	32	256	100	156	44.399	TER32

### 特点:

注:

- ◎ 刚性功能确保加工中心主轴转动同进给精确同步, 使用专用基础刀柄。
- ◎ 刚性攻牙刀柄可使用 ER 筒夹代替, 作为夹持钻头、铰刀和铣刀工具刀柄。
- ◎ 采用刚性攻牙本体, 使用时, 螺帽请勿过度锁紧, 以免造成损坏, ER 扳手为另购品。

### Features:

- ◎ Rigid function ensures machining center spindle rotate in synchronized precise, While MTB holder in use.
- ◎ Can be replaced by ER collet for gripping cutting tool, Drill bit, and draw bolt and so on.
- ◎ Don't lock excessively of the clamping nut in case of damage. Wrench not included.

MTA3 - TER - 16 - 100L

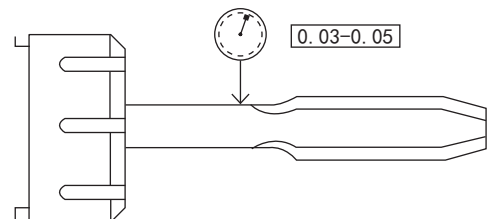
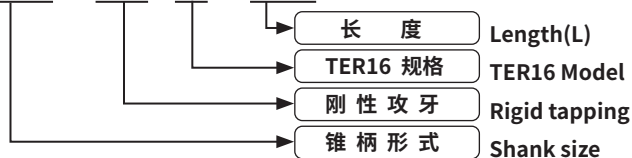

# MTB-TER-A 莫氏后拉式刚性伸缩攻牙刀柄

## MORSE RIGID TAPER HOLDER-(MTB)

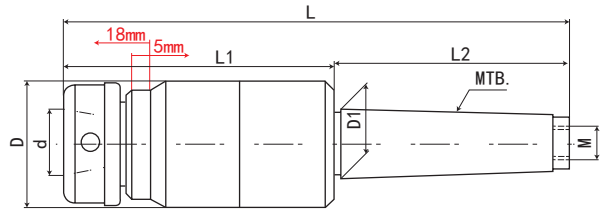

P.131



P.106



P.133

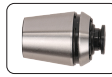

P.P34

规格 / 型号 Model	攻牙范围 Tapping range	D	d	M	D1	L	L1	L2	筒夹名称 Collet name
MTB2-TER16-A-100L	M2-M12	46	16	M10*1.5P	17.780	168	100	68	TER16
MTB2-TER20-A-100L	M2-M16	46	20	M10*1.5P	17.780	168	100	68	TER20
规格 / 型号 Model	攻牙范围 Tapping range	D	d	M	D1	L	L1	L2	筒夹名称 Collet name
MTB3-TER16-A-100L	M2-M12	46	16	M12*1.75P	23.825	185	100	85	TER16
MTB3-TER20-A-100L	M2-M16	46	20	M12*1.75P	23.825	185	100	85	TER20
MTB3-TER25-A-100L	M2-M22	46	25	M12*1.75P	23.825	185	100	85	TER25
MTB3-TER32-A-100L	M2-M30	46	32	M12*1.75P	23.825	185	100	85	TER32
规格 / 型号 Model	攻牙范围 Tapping range	D	d	M	D1	L	L1	L2	筒夹名称 Collet name
MTB4-TER16-A-100L	M2-M12	46	16	M16*2.0P	31.267	208	100	108	TER16
MTB4-TER20-A-100L	M2-M16	46	20	M16*2.0P	31.267	208	100	108	TER20
MTB4-TER25-A-100L	M2-M22	46	25	M16*2.0P	31.267	208	100	108	TER25
MTB4-TER32-A-100L	M2-M30	46	32	M16*2.0P	31.267	208	100	108	TER32

### 特点:

注:

- ◎ 刚性功能确保加工中心主轴转动同进给精确同步，使用专用基础刀柄。
- ◎ 刚性攻牙刀柄可使用 ER 筒夹代替，作为夹持钻头、铰刀和铣刀工具刀柄。
- ◎ 采用刚性攻牙本体，使用时，螺帽请勿过度锁紧，以免造成损坏，ER 扳手为另购品。

### Features:

- ◎ Rigid function ensures machining center spindle rotate in synchronized precise, While MTB holder in use.
- ◎ Can be replaced by ER collet for gripping cutting tool, Drill bit, and draw bolt and so on.
- ◎ Don't lock excessively of the clamping nut in case of damage. Wrench not included.

MTB2 - TER - 16 - 100L

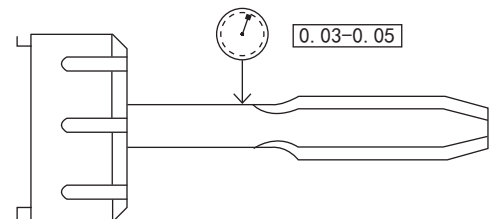
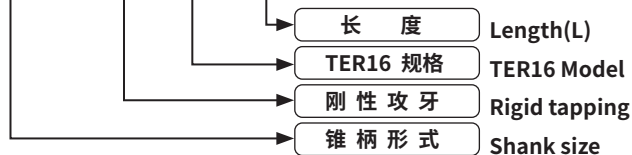

TAPPING CHUCK SERIES 攻丝夹头系列

# 攻丝夹头系列 TAPPING CHUCK SERIES

## BT-TER-B 刚性伸缩攻牙刀柄

## RIGID TENSION AND COMPRESSION TAPER HOLDER/TER-B

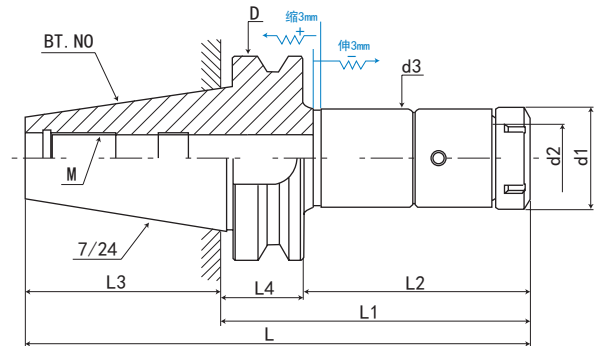

P.131



P.106



P.133



P.129



P.P34

规格 / 型号 Model	BT.NO	L	L1	L2	L3	L4	d1	d2	使用筒夹	攻丝范围	D	M
BT30-TER16-B-100L	BT30	148.4	100	73	48.4	27	28	16	TER16	M2-M12	46	M12*1.75P
BT30-TER20-B-100L		148.4	100	73			34	20	TER20	M2-M16		
BT30-TER25-B-100L		148.4	100	73			42	25	TER25	M2-M22		
BT30-TER32-B-100L		148.4	100	73			50	32	TER32	M2-M30		
BT30-TER40-B-100L		148.4	100	73			63	40	TER40	M2-M36		
规格 / 型号 Model	BT.NO	L	L1	L2	L3	L4	d1	d2	使用筒夹	攻丝范围	D	M
BT40-TER16-B-100L	BT40	165.4	100	73	65.4	27	28	16	TER16	M2-M12	63	M16*2.0P
BT40-TER20-B-100L		165.4	100	73			34	20	TER20	M2-M16		
BT40-TER25-B-100L		165.4	100	73			42	25	TER25	M2-M22		
BT40-TER32-B-100L		165.4	100	73			50	32	TER32	M2-M30		
BT40-TER40-B-120L		185.4	120	93			63	40	TER40	M2-M36		
规格 / 型号 Model	BT.NO	L	L1	L2	L3	L4	d1	d2	使用筒夹	攻丝范围	D	M
BT50-TER16-B-110L	BT50	211.8	110	72	101.8	38	28	16	TER16	M2-M12	100	M24*3.0P
BT50-TER20-B-110L		211.8	110	72			34	20	TER20	M2-M16		
BT50-TER25-B-110L		211.8	110	72			42	25	TER25	M2-M22		
BT50-TER32-B-130L		222.8	130	92			50	32	TER32	M2-M30		
BT50-TER40-B-140L		232.8	140	102			63	40	TER40	M2-M36		

### 特点:

注:

- ◎ 本体规格: JIS MAS 403 BT
- ◎ 刚性功能确保加工中心主轴转动同进给精确同步, 使用专用基础刀柄。
- ◎ 刚性攻牙刀柄可使用 ER 筒夹代替, 作为夹持钻头、铰刀和铣刀工具刀柄。
- ◎ 采用刚性攻牙本体, 使用时, 螺帽请勿过度锁紧, 以免造成损坏, ER 扳手为另购品。
- ◎ 具有深孔攻牙和深层台阶面攻牙功能。

### Features:

- ◎ Spindle Conicity Standard: JIS MAS 403 BT
- ◎ Rigid function ensures machining center spindle rotate in synchronized precise, While MTB holder in use.
- ◎ Can be replaced by ER collet for gripping cutting tool, Drill bit, and draw bolt and so on.
- ◎ Don't lock excessively of the clamping nut in case of damage, Wrench not included.

BT30 - TER 16 - 100L

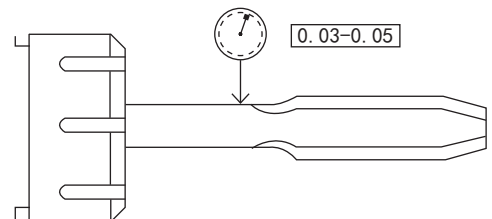



# SK/DAT-TER-B 刚性伸缩攻牙刀柄

# RIGID TENSION AND COMPRESSION TAPER HOLDER/TER-B

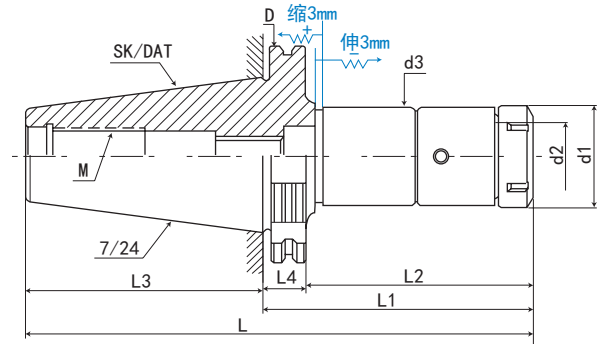
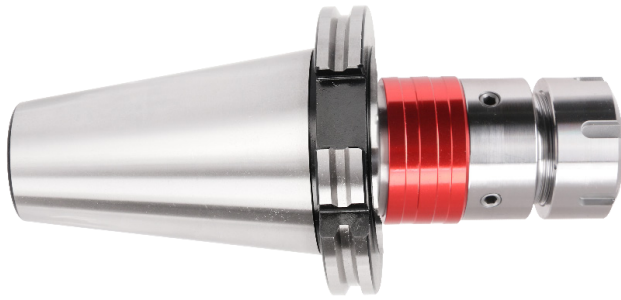

P. I31



P. I06



P. I33



P. I24



P. P34

规格 / 型号 Model	SK.NO	L	L1	L2	L3	L4	d1	d2	使用筒夹	攻丝范围	D	M
SK40-TER16-B-100L	SK40	168.4	100	82	68.4	16	28	16	TER16	M2-M12	63.55	M16*2.0P
SK40-TER20-B-100L		168.4	100	82			34	20	TER20	M2-M16		
SK40-TER25-B-100L		168.4	100	82			42	25	TER25	M2-M22		
SK40-TER32-B-100L		168.4	100	82			50	32	TER32	M2-M30		
SK40-TER40-B-120L		188.4	120	102			63	40	TER40	M2-M36		
规格 / 型号 Model	SK.NO	L	L1	L2	L3	L4	d1	d2	使用筒夹	攻丝范围	D	M
SK50-TER16-B-110L	SK50	211.7	110	91	101.75	16	28	16	TER16	M2-M12	97.5	M24*3.0P
SK50-TER20-B-110L		211.7	110	91			34	20	TER20	M2-M16		
SK50-TER25-B-110L		211.7	110	91			42	25	TER25	M2-M22		
SK50-TER32-B-130L		231.7	130	101			50	32	TER32	M2-M30		
SK50-TER40-B-140L		241.7	140	111			63	40	TER40	M2-M36		

## 特点:

注:

- ◎ 本体规格: DIN69871-A 或 GB10944
- ◎ 刚性功能确保加工中心主轴转动同进给精确同步, 使用专用基础刀柄。
- ◎ 刚性攻牙刀柄可使用 ER 筒夹代替, 作为夹持钻头、铰刀和铣刀工具刀柄。
- ◎ 采用刚性攻牙本体, 使用时, 螺帽请勿过度锁紧, 以免造成损坏, ER 扳手为另购品。
- ◎ 具有深孔攻牙和深层台阶面攻牙功能。

## Features:

- ◎ Spindle Conicity Standard: JDIN69871A or GB10944
- ◎ Rigid function ensures machining center spindle rotate in synchronized precise, While MTB holder in use.
- ◎ Can be replaced by ER collet for gripping cutting tool, Drill bit, and draw bolt and so on.
- ◎ Don't lock excessively of the clamping nut in case of damage, Wrench not included.

SK40 - TER 16 - 100L

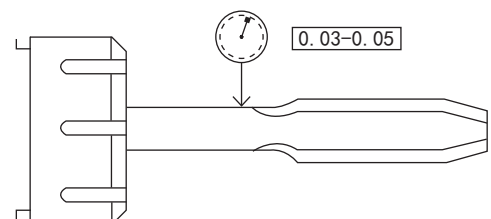

TAPPING CHUCK SERIES 攻丝夹头系列

# 攻丝夹头系列 TAPPING CHUCK SERIES

## NT-TER-B 刚性伸缩攻牙刀柄

## RIGID TENSION AND COMPRESSION TAPER HOLDER/TER-B

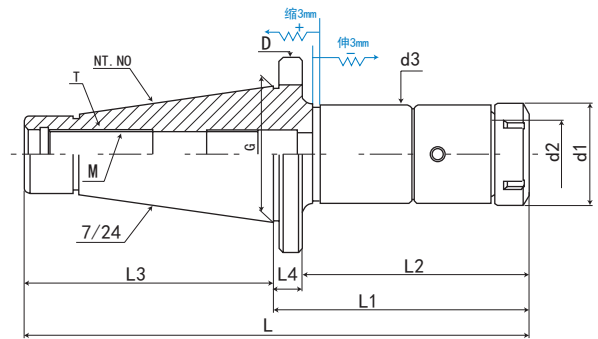

P.131



P.106



P.133



P.P34

规格 / 型号 Model	NT.NO	L	L1	L2	L3	L4	d1	d2	使用筒夹	攻丝范围	D	M
NT40-TER16-B-100L	NT40	193.4	100	73	93.4	12	28	16	TER16	M2-M12	63	M16*2.0P
NT40-TER20-B-100L		193.4	100	73			34	20	TER20	M2-M16		
NT40-TER25-B-100L		193.4	100	73			42	25	TER25	M2-M22		
NT40-TER32-B-100L		193.4	100	73			50	32	TER32	M2-M30		
NT40-TER40-B-120L		213.4	120	93			63	40	TER40	M2-M36		
规格 / 型号 Model	NT.NO	L	L1	L2	L3	L4	d1	d2	使用筒夹	攻丝范围	D	M
NT50-TER16-B-110L	NT50	236.8	110	72	126.8	15	28	16	TER16	M2-M12	100	M24*3.0P
NT50-TER20-B-110L		236.8	110	72			34	20	TER20	M2-M16		
NT50-TER25-B-110L		236.8	110	72			42	25	TER25	M2-M22		
NT50-TER32-B-130L		256.8	130	92			50	32	TER32	M2-M30		
NT50-TER40-B-140L		266.8	140	102			63	40	TER40	M2-M36		

### 特点:

注:

- ◎ 本体规格: GB3837/DIN2080
- ◎ 刚性功能确保加工中心主轴转动同进给精确同步, 使用专用基础刀柄。
- ◎ 刚性攻牙刀柄可使用 ER 筒夹代替, 作为夹持钻头、铰刀和铣刀工具刀柄。
- ◎ 采用刚性攻牙本体, 使用时, 螺帽请勿过度锁紧, 以免造成损坏, ER 扳手为另购品。
- ◎ 具有深孔攻牙和深层台阶面攻牙功能。

### Features:

- ◎ Spindle Conicity Standard: GB3837/DIN2080
- ◎ Rigid function ensures machining center spindle rotate in synchronized precise, While MTB holder in use.
- ◎ Can be replaced by ER collet for gripping cutting tool, Drill bit, and draw bolt and so on.
- ◎ Don't lock excessively of the clamping nut in case of damage, Wrench not included.

NT40 - TER-16 - 100L

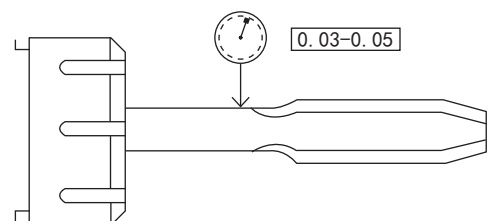
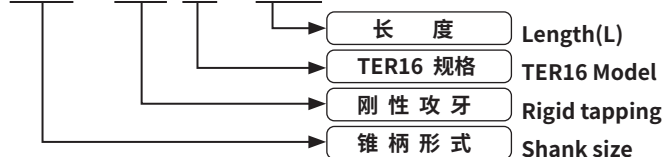

# C-TER-B 直柄刚性伸缩攻牙刀柄

# STRAIGHT SHANK RIGID TAPER HOLDER C-TER-B

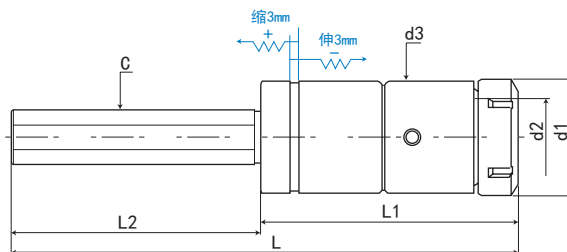
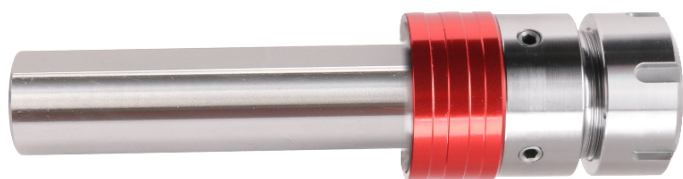

P.131



P.106



P.133



P.P34

规格 / 型号 Model	C	L	L1	L2	d1	d2	d3	使用筒夹	攻丝范围
C20-TER16-B-80L	20	160	80	80	28	16	28	TER16	M2-M12
C20-TER20-B-80L	20	160	80	80	34	20	34	TER20	M2-M16
C20-TER25-B-80L	20	160	80	80	42	25	42	TER25	M2-M22
C20-TER32-B-100L	20	180	100	80	50	32	50	TER32	M2-M30
规格 / 型号 Model	C	L	L1	L2	d1	d2	d3	使用筒夹	攻丝范围
C25-TER16-B-80L	25	160	80	80	28	16	28	TER16	M2-M12
C25-TER20-B-80L	25	160	80	80	34	20	34	TER20	M2-M16
C25-TER25-B-80L	25	160	80	80	42	25	42	TER25	M2-M22
C25-TER32-B-100L	25	180	100	80	50	32	50	TER32	M2-M30
规格 / 型号 Model	C	L	L1	L2	d1	d2	d3	使用筒夹	攻丝范围
C32-TER16-B-80L	32	160	80	80	28	16	28	TER16	M2-M12
C32-TER20-B-80L	32	160	80	80	34	20	34	TER20	M2-M16
C32-TER25-B-80L	32	160	80	80	42	25	42	TER25	M2-M22
C32-TER32-B-100L	32	180	100	80	50	32	50	TER32	M2-M30

## 特点:

注:

- ◎ 刚性功能确保加工中心主轴转动同进给精确同步，使用专用基础刀柄。
- ◎ 刚性攻牙刀柄可使用 ER 筒夹代替，作为夹持钻头、铰刀和铣刀工具刀柄。
- ◎ 采用刚性攻牙本体，使用时，螺帽请勿过度锁紧，以免造成损坏，ER 扳手为另购品。

## Features:

- ◎ Rigid function ensures machining center spindle rotate in synchronized precise, While MTB holder in use.
- ◎ Can be replaced by ER collet for gripping cutting tool, Drill bit, and draw bolt and so on.
- ◎ Don't lock excessively of the clamping nut in case of damage, Wrench not included.

C20 - TER 16 - 80L

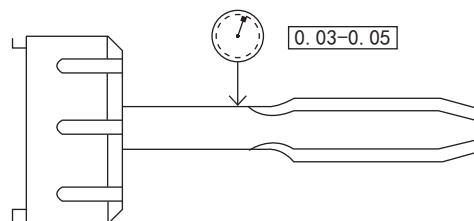
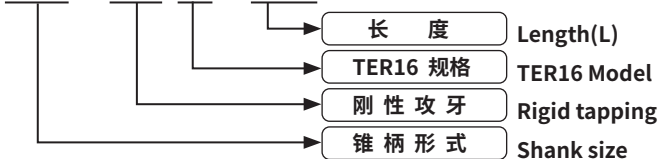

TAPPING  
CHUCK SERIES  
攻丝夹头系列

# 攻丝夹头系列 TAPPING CHUCK SERIES

## MTA-TER-B 莫氏扁尾刚性伸缩攻牙刀柄

MORSE RIGID TENSION AND COMPRESSION TAPER HOLDER (MTA)

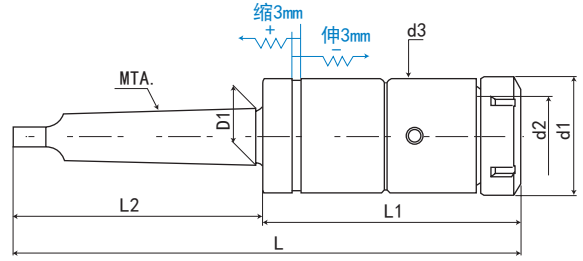
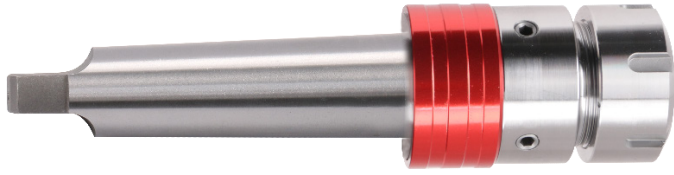

P.131



P.106



P.133



P.P34

规格 / 型号 Model	攻牙范围 Tapping range	d1	d2	d3	L	L1	L2	D1	筒夹名称 Collet name
MTA2-TER16-B-100L	M2-M12	28	16	28	184	100	84	17.780	TER16
MTA2-TER20-B-100L	M2-M16	34	20	34	184	100	84	17.780	TER20
MTA2-TER25-B-100L	M2-M22	42	25	42	184	100	84	17.780	TER25
规格 / 型号 Model	攻牙范围 Tapping range	d1	d2	d3	L	L1	L2	D1	筒夹名称 Collet name
MTA3-TER16-B-100L	M2-M12	28	16	28	199	100	99	23.825	TER16
MTA3-TER20-B-100L	M2-M16	34	20	34	199	100	99	23.825	TER20
MTA3-TER25-B-100L	M2-M22	42	25	42	199	100	99	23.825	TER25
MTA3-TER32-B-100L	M2-M30	50	32	50	199	100	99	23.825	TER32
规格 / 型号 Model	攻牙范围 Tapping range	d1	d2	d3	L	L1	L2	D1	筒夹名称 Collet name
MTA4-TER16-B-100L	M2-M12	28	16	28	224	100	124	31.267	TER16
MTA4-TER20-B-100L	M2-M16	34	20	34	224	100	124	31.267	TER20
MTA4-TER25-B-100L	M2-M22	42	25	42	224	100	124	31.267	TER25
MTA4-TER32-B-100L	M2-M30	50	32	50	224	100	124	31.267	TER32
规格 / 型号 Model	攻牙范围 Tapping range	D	d	d3	L	L1	L2	D1	筒夹名称 Collet name
MTA5-TER32-B-100L	M2-M30	50	32	50	256	100	156	44.399	TER32

攻丝夹头系列  
TAPPING  
CHUCK SERIES

### 特点:

注:

- ◎ 刚性功能确保加工中心主轴转动同进给精确同步, 使用专用基础刀柄。
- ◎ 刚性攻牙刀柄可使用 ER 筒夹代替, 作为夹持钻头、铰刀和铣刀工具刀柄。
- ◎ 采用刚性攻牙本体, 使用时, 螺帽请勿过度锁紧, 以免造成损坏, ER 扳手为另购品。

### Features:

- ◎ Rigid function ensures machining center spindle rotate in synchronized precise, While MTB holder in use.
- ◎ Can be replaced by ER collet for gripping cutting tool, Drill bit, and draw bolt and so on.
- ◎ Don't lock excessively of the clamping nut in case of damage. Wrench not included.

MTA3 - TER - 16 - 100L

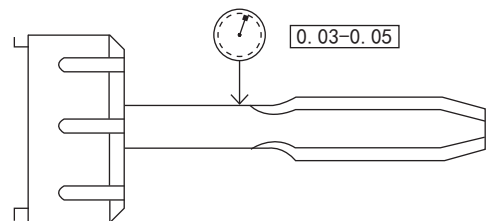

# MTB-TER-B 莫氏后拉式刚性伸缩攻牙刀柄

MORSE RIGID TENSION AND COMPRESSION TAPER HOLDER (MTB)

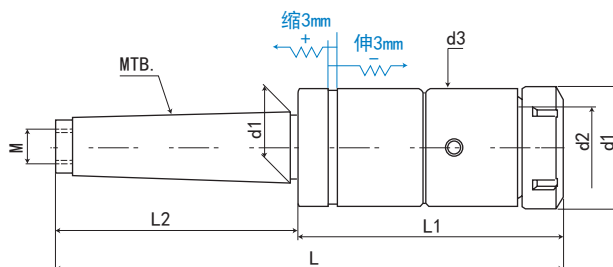
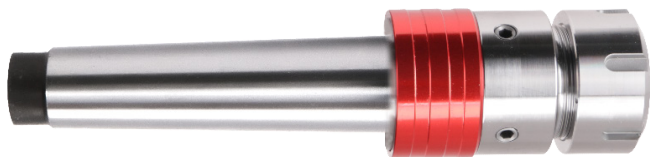

P.131



P.106



P.133



P.P34

规格 / 型号 Model	攻牙范围 Tapping range	d1	d2	d3	L	L1	L2	D1	M	筒夹名称 Collet name
MTB2-TER16-B-100L	M2-M12	28	16	28	168	100	68	17.780	M10*1.5P	TER16
MTB2-TER20-B-100L	M2-M16	34	20	34	168	100	68	17.780	M10*1.5P	TER20
MTB2-TER25-B-100L	M2-M22	42	25	42	168	100	68	17.780	M10*1.5P	TER25
规格 / 型号 Model	攻牙范围 Tapping range	d1	d2	d3	L	L1	L2	D1	M	筒夹名称 Collet name
MTB3-TER16-B-100L	M2-M12	28	16	28	185	100	85	23.825	M12*1.75P	TER16
MTB3-TER20-B-100L	M2-M16	34	20	34	185	100	85	23.825	M12*1.75P	TER20
MTB3-TER25-B-100L	M2-M22	42	25	42	185	100	85	23.825	M12*1.75P	TER25
MTB3-TER32-B-100L	M2-M30	50	32	50	185	100	85	23.825	M12*1.75P	TER32
规格 / 型号 Model	攻牙范围 Tapping range	d1	d2	d3	L	L1	L2	D1	M	筒夹名称 Collet name
MTB4-TER16-B-100L	M2-M12	28	16	28	208	100	108	31.267	M16*2.0P	TER16
MTB4-TER20-B-100L	M2-M16	34	20	34	208	100	108	31.267	M16*2.0P	TER20
MTB4-TER25-B-100L	M2-M22	42	25	42	208	100	108	31.267	M16*2.0P	TER25
MTB4-TER32-B-100L	M2-M30	50	32	50	208	100	108	31.267	M16*2.0P	TER32
规格 / 型号 Model	攻牙范围 Tapping range	D	d	d3	L	L1	L2	D1	M	筒夹名称 Collet name
MTB5-TER32-100L	M2-M30	50	32	50	236	100	136	44.399	M20*2.5P	TER32

## 特点:

注:

- ◎ 刚性功能确保加工中心主轴转动同进给精确同步，使用专用基础刀柄。
- ◎ 刚性攻牙刀柄可使用 ER 筒夹代替，作为夹持钻头、铰刀和铣刀工具刀柄。
- ◎ 采用刚性攻牙本体，使用时，螺帽请勿过度锁紧，以免造成损坏，ER 扳手为另购品。

## Features:

- ◎ Rigid function ensures machining center spindle rotate in synchronized precise, While MTB holder in use.
- ◎ Can be replaced by ER collet for gripping cutting tool, Drill bit, and draw bolt and so on.
- ◎ Don't lock excessively of the clamping nut in case of damage. Wrench not included.

MTB3 - TER - 16 - 100L

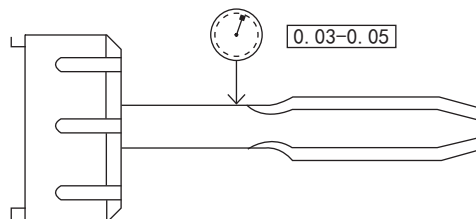

TAPPING  
CHUCK SERIES  
攻丝夹头系列

# 攻丝夹头系列 TAPPING CHUCK SERIES

## SL-TER 实用型直柄伸缩攻牙器

## SL-TER PRACTICAL STRAIGHT SHANK TAPPER

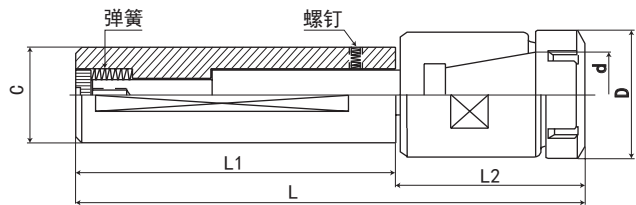

P.131

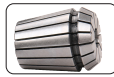

P.106



P.133



P.P34

规格 / 型号 Model	L	L1	L2	C	D	d	筒夹 Collet	攻牙能力 Capacity	伸缩量	
									伸 (+)	缩 (-)
SL16-TER11-(M/A)-80L	112	80	32	16	16/19	11	TER11	M2-M10	8mm	0mm
SL16-TER16-(M/A)-80L	120	80	40	16	22/28	16	TER16	M2-M12	8mm	0mm
SL20-TER11-(M/A)-80L	112	80	32	20	16/19	11	TER11	M2-M10	8mm	0mm
SL20-TER16-(M/A)-80L	120	80	40	20	22/28	16	TER16	M2-M12	8mm	0mm
SL20-TER20-(M/A)-80L	125	80	45	20	28/34	20	TER20	M2-M16	8mm	0mm
SL20-TER25-(UM)-80L	130	80	50	20	42	25	TER25	M2-M22	8mm	0mm
SL25-TER11-(M/A)-80L	112	80	32	25	16/19	11	TER11	M2-M10	8mm	0mm
SL25-TER16-(M/A)-80L	120	80	40	25	22/28	16	TER16	M2-M12	8mm	0mm
SL25-TER20-(M/A)-80L	125	80	45	25	28/34	20	TER20	M2-M16	8mm	0mm
SL25-TER25-(UM)-80L	130	80	50	25	42	25	TER25	M2-M22	8mm	0mm
SL25-TER32-(UM)-80L	135	80	55	25	50	32	TER32	M2-M30	10mm	0mm
SL32-TER25-(UM)-80L	130	80	50	32	42	25	TER25	M2-M22	8mm	0mm
SL32-TER32-(UM)-80L	135	80	55	32	50	32	TER32	M2-M30	10mm	0mm

### 特点:

注:

- ◎ 可使用 ER 筒夹夹持丝攻，配合刚性攻牙筒夹则效果倍增。
- ◎ 可建议使用 A 型螺帽，以增加夹持力。
- ◎ TP 型内建浮动装置使工作重复定位可自动修正偏差。
- ◎ 用於刀具不旋转の場合（如：车床、专用机械等）。

### 注释:

注:

- ◎ 在加工材料较硬，则 M/MIN 应同时变得较慢。
- ◎ 在使用直柄伸缩 TER 攻牙器，请先决定车床主轴运转速度，否则将会因速度太快或太慢而造成柄及攻牙器损坏或破碎。
- ◎  $S=V/P$  S= 中文主轴转速 V=M/min P=PICH.

### 例:

注:

- ◎ 工件材质: S45 以, V=400-440
- ◎ 牙距 = 1.5P
- ◎  $S=V/P=440/1.5=293=R.P.M$

### Features:

- ◎ Using ER collet holder tap, rigid tapping collets with the effect of doubling.
- ◎ May suggest that uses the A nut, increases the chucking power.
- ◎ In TP constructs the fluctuation installment to cause the duplication of work localization to be possible to revise the deviation automatically.
- ◎ Uses in situation which the cutting tool does not revolve (for example: Lathe, special-purpose machinery and so on).

### Note:

- ◎ If the processing material is harder, the M/min should become slower relatively.
- ◎ Before using the Straight TER Tapper, please decide spindle running speed of Lathe Machine, otherwise it will make the Shank and Tapping break or split because of too fast or too slow speed.
- ◎  $S=V/P$  S=Spindle running speed V=M/min P=PICH

### For Example:

- ◎ Processing material: S45C, V=400-440
- ◎ Pitch=1.5P
- ◎  $S=V/P=440/1.5=293=R.P.M$



# ERG 刚性攻牙筒夹 (公制)

# ERG RIGID TAP COLLET (ISO)

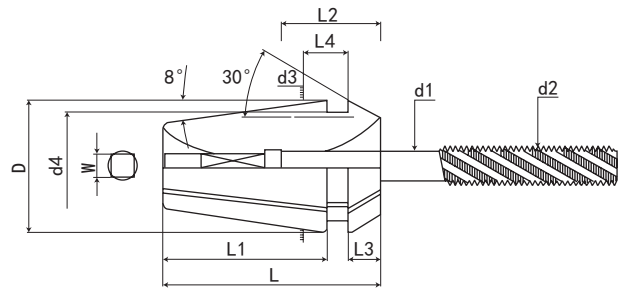

Outer diameter size according to DIN6499-B

规格 / 型号 Model	D	d3	d4	L	L1	L3	L4	Capacity	重量 KGS
ER16G	17	16	13.8	27.5	20.8	4.0	6.26	M3-M10	0.003
ER20G	21	20	17.4	31.5	23.9	4.8	6.36	M3-M17	0.04
ER25G	26	25	22	34	25.9	5.0	6.66	M3-M22	0.06
ER32G	33	32	29.2	40	31.8	5.5	7.16	M3-M27	0.10
ER40G	42	40	36.2	46	35.5	7	7.66	M3-M27	0.25
ER50G	52	50	46	60	46	8.5	12.6	M6-M36	0.4

- ◎材料: SUJ2
- ◎Material: SUJ2
- ◎硬度: 44-48HRC
- ◎Hardness: 44-48HRC

## ER16G

规格 / 型号 Model	d1	W □	通用标准 Standard d2				L2
			ISO	JIS	DIN371	DIN376	
ER16G-2.24	2.24	1.8	M3				15
ER16G-2.5	2.5	2.1				M3.5	
		2	M3.5				
ER16G-2.8	2.8	2.1				M4	18
ER16G-3	3	2.5		M2			
ER16G-3.15	3.15	2.5	M3/M4				
ER16G-3.5	3.5	2.7			M3	M5	
ER16G-3.55	3.55	2.8	M3.5/M4.5				
		3			M3.5		
ER16G-4	4	3.1		M3			
		3.15	M4/M5				
		3.4			M4	M6	
ER16G-4.5	4.5	3.55	M6				
		4	M5	M4/M4.5			
ER16G-5.5	5.5	4.3				M7	
		4.5		M5/M5.5			
ER16G-6	6	4.5		M6			
		4.9			M5/M6	M8	
ER16G-6.2	6.2	5		M7/M8			
ER16G-6.3	6.3	5	M6/M8				
ER16G-7	7	5.5		M9/M10	M7	M10	
ER16G-8	8	6		M11			
		6.2			M8	M11	
		6.3	M8/M10				
ER16G-8.5	8.5	6.5		M12			
ER16G-9	9	7				M12	
		7.1	M12				
ER16G-10	10	8	M10		M10		

## ER20G

规格 / 型号 Model	d1	W □	通用标准 Standard d2				L2
			ISO	JIS	DIN371	DIN376	
ER20G-2.24	2.24	1.8	M3				15
ER20G-2.5	2.5	2.1				M3.5	
		2	M3.5				
ER20G-2.8	2.8	2.1				M4	18
ER20G-3	3	2.5		M2			
ER20G-3.15	3.15	2.5	M3/M4				
ER20G-3.5	3.5	2.7			M3	M5	
ER20G-3.55	3.55	2.8	M3.5/M4.5				
		3			M3.5		
ER20G-4	4	3.1		M3			
		3.15	M4/M5				
		3.4			M4	M6	
ER20G-4.5	4.5	3.55	M6				
		4	M5	M4/M4.5			
ER20G-5.5	5.5	4.3				M7	
		4.5		M5/M5.5			
ER20G-6	6	4.5		M6			
		4.9			M5/M6	M8	
ER20G-6.2	6.2	5		M7/M8			
ER20G-6.3	6.3	5	M6/M8				
ER20G-7	7	5.5		M9/M10	M7	M10	
ER20G-8	8	6		M11			
		6.2			M8	M11	
		6.3	M8/M10				
ER20G-8.5	8.5	6.5		M12			
ER20G-9	9	7				M12	
		7.1	M12				
ER20G-10	10	8	M10		M10		
ER20G-10.5	10.5	8		M14/M15			
ER20G-11	11	9				M14	
ER20G-11.2	11.2	9	M14				
ER20G-12	12	9				M16	
ER20G-12.5	12.5	10	M16	M16			
ER20G-13	13	10		M17			

◎订购时, 请注明标准和 d2、d1、W 尺寸

◎ When ordering please specify the collet type, and the size of d2、d1、W.

TAPPING CHUCK SERIES 攻丝夹头系列

# 攻丝夹头系列 TAPPING CHUCK SERIES

## ERG 刚性攻牙筒夹 (公制)

## ERG RIGID TAP COLLET (ISO)

### ER25G

规格 / 型号 Model	d1	W □	通用标准 Standard d2				L2
			ISO	JIS	DIN371	DIN376	
ER25G-2.24	2.24	1.8	M3				15
ER25G-2.5	2.5	2.1				M3.5	
		2	M3.5				
ER25G-2.8	2.8	2.1				M4	18
ER25G-3	3	2.5		M2			
ER25G-3.15	3.15	2.5	M3/M4				
ER25G-3.5	3.5	2.7			M3	M5	
ER25G-3.55	3.55	2.8	M3.5/M4.5				
ER25G-4	4	3			M3.5		
		3.1		M3			
		3.15	M4/M5				
ER25G-4.5	4.5	3.4			M4	M6	
		3.55	M6				
ER25G-5	5	4	M5	M4/M4.5			
ER25G-5.5	5.5	4.3				M7	
		4.5		M5/M5.5			
ER25G-6	6	4.5			M6		
		4.9			M5/M6	M8	
ER25G-6.2	6.2	5		M7/M8			
ER25G-6.3	6.3	5	M6/M8				
ER25G-7	7	5.5		M9/M10	M7	M10	
ER25G-8	8	6			M11		
		6.2			M8	M11	
		6.3	M8/M10				
ER25G-8.5	8.5	6.5		M12			
ER25G-9	9	7				M12	
		7.1	M12				
ER25G-10	10	8	M10		M10		
ER25G-10.5	10.5	8		M14/M15			
ER25G-11	11	9				M14	
ER25G-11.2	11.2	9	M14				
ER25G-12	12	9				M16	
ER25G-12.5	12.5	10	M16	M16			
ER25G-13	13	10		M17			
ER25G-14	14	11			M18	M18	
		11.2	M18/M20				
ER25G-15	15	12		M20			
ER25G-16	16	12				M20	
		12.5	M22				

### ER32G

规格 / 型号 Model	d1	W □	通用标准 Standard d2				L2
			ISO	JIS	DIN371	DIN376	
ER32G-2.24	2.24	1.8	M3				15
ER32G-2.5	2.5	2.1				M3.5	
		2	M3.5				
ER32G-2.8	2.8	2.1				M4	18
ER32G-3	3	2.5		M2			
ER32G-3.15	3.15	2.5	M3/M4				
ER32G-3.5	3.5	2.7			M3	M5	
ER32G-3.55	3.55	2.8	M3.5/M4.5				
ER32G-4	4	3			M3.5		
		3.1		M3			
		3.15	M4/M5				
ER32G-4.5	4.5	3.4			M4	M6	
		3.55	M6				
ER32G-5	5	4	M5	M4/M4.5			
ER32G-5.5	5.5	4.3				M7	
		4.5		M5/M5.5			
ER32G-6	6	4.5			M6		
		4.9			M5/M6	M8	
ER32G-6.2	6.2	5		M7/M8			
ER32G-6.3	6.3	5	M6/M8				
ER32G-7	7	5.5		M9/M10	M7	M10	
ER32G-8	8	6			M11		
		6.2			M8	M11	
		6.3	M8/M10				
ER32G-8.5	8.5	6.5		M12			
ER32G-9	9	7				M12	
		7.1	M12				
ER32G-10	10	8	M10		M10		
ER32G-10.5	10.5	8		M14/M15			
ER32G-11	11	9				M14	
ER32G-11.2	11.2	9	M14				
ER32G-12	12	9				M16	
ER32G-12.5	12.5	10	M16	M16			
ER32G-13	13	10		M17			
ER32G-14	14	11			M18	M18	
		11.2	M18/M20				
ER32G-15	15	12		M20			
ER32G-16	16	12				M20	
		12.5	M22				
ER32G-17	17	13		M22			
ER32G-18	18	14.5				M22/M24	
		14	M24				
ER32G-19	19	15		M24/M25			
ER32G-20	20	15		M26/M27			



攻丝夹头系列  
TAPPING  
CHUCK SERIES

# ERG 刚性攻牙筒夹 (公制)

# ERG RIGID TAP COLLET (ISO)

## ER40G

规格 / 型号 Model	d1	W □	通用标准 Standard d2				L2
			ISO	JIS	DIN371	DIN376	
ER40G-2.24	2.24	1.8	M3				15
ER40G-2.5	2.5	2.1				M3.5	
		2	M3.5				
ER40G-2.8	2.8	2.1				M4	18
ER40G-3	3	2.5		M2			
ER40G-3.15	3.15	2.5	M3/M4				
ER40G-3.5	3.5	2.7			M3	M5	
ER40G-3.55	3.55	2.8	M3.5/M4.5				
ER40G-4	4	3			M3.5		
		3.1		M3			
		3.15	M4/M5				
ER40G-4.5	4.5	3.4			M4	M6	
		3.55	M6				
ER40G-5	5	4	M5	M4/M4.5			
ER40G-5.5	5.5	4.3				M7	
		4.5		M5/M5.5			
ER40G-6	6	4.5		M6			
		4.9			M5/M6	M8	
ER40G-6.2	6.2	5		M7/M8			
ER40G-6.3	6.3	5	M6/M8				
ER40G-7	7	5.5		M9/M10	M7	M10	
ER40G-8	8	6		M11			
		6.2			M8	M11	
		6.3	M8/M10				
ER40G-8.5	8.5	6.5		M12			
ER40G-9	9	7				M12	
		7.1	M12				
ER40G-10	10	8	M10		M10		
ER40G-10.5	10.5	8		M14/ M15			
ER40G-11	11	9				M14	
ER40G-11.2	11.2	9	M14				
ER40G-12	12	9				M16	
ER40G-12.5	12.5	10	M16	M16			
ER40G-13	13	10		M17			
ER40G-14	14	11		M18		M18	
		11.2	M18/M20				
ER40G-15	15	12		M20			
ER40G-16	16	12				M20	
		12.5	M22				
ER40G-17	17	13		M22			
ER40G-18	18	14.5				M22/M24	
		14	M24				
ER40G-19	19	15		M24/ M25			
ER40G-20	20	15		M26/ M27			

## ER50G

规格 / 型号 Model	d1	W □	通用标准 Standard d2				L2
			ISO	JIS	DIN371	DIN376	
ER50G-6	6	4.5		M6			18
		4.9			M5/M6	M8	
ER50G-6.2	6.2	5		M7/M8			
ER50G-6.3	6.3	5	M6/M8				
ER50G-7	7	5.5		M9/M10	M7	M10	
ER50G-8	8	6		M11			
		6.2			M8	M11	
		6.3	M8/M10				
ER50G-8.5	8.5	6.5		M12			
ER50G-9	9	7				M12	
		7.1	M12				
ER50G-10	10	8	M10		M10		
ER50G-10.5	10.5	8		M14/ M15			
ER50G-11	11	9				M14	
ER50G-11.2	11.2	9	M14				
ER50G-12	12	9				M16	
ER50G-12.5	12.5	10	M16	M16			
ER50G-13	13	10		M17			
ER50G-14	14	11		M18		M18	
		11.2	M18/M20				
ER50G-15	15	12		M20			
ER50G-16	16	12				M20	
		12.5	M22				
ER50G-17	17	13		M22			
ER50G-18	18	14.5				M22/ M24	
		14	M24				
ER50G-19	19	15		M24/ M25			
ER50G-20	20	15		M26/ M27			
		17		M28			
ER50G-21	21	17					
ER50G-22	22	18				M30	
ER50G-22.4	22.4	18	M33				
ER50G-23	23	17		M30			
ER50G-25	25	19		M33			
		20	M36				
ER50G-28	28	21		M36			



# 攻丝夹头系列 TAPPING CHUCK SERIES

## ERG 刚性攻牙筒夹 (英制)

## ERG RIGID TAP COLLET (INCH)

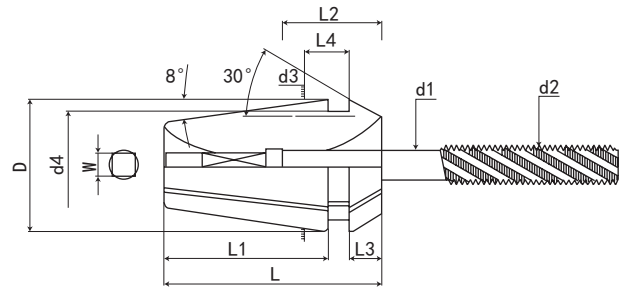

ER16G RIGID TAP COLLET				ER25G RIGID TAP COLLET			
d2	d1	SW	W □	d2	d1	SW	W □
5/32	0.168"	0.151"	0.131"	5/32	0.168"	0.151"	0.131"
3/16	0.194"	0.180"	0.152"	3/16	0.194"	0.180"	0.152"
7/32	0.220"	0.198"	0.165"	7/32	0.220"	0.198"	0.165"
1/4	0.255"	0.198"	0.191"	1/4	0.255"	0.198"	0.191"
ER20G RIGID TAP COLLET				5/16	0.318"	0.258"	0.238"
d2	d1	SW	W □	7/16	0.323"	0.263"	0.242"
5/32	0.168"	0.151"	0.131"	1/2	0.367"	0.307"	0.275"
3/16	0.194"	0.180"	0.152"	3/8	0.381"	0.321"	0.286"
7/32	0.220"	0.198"	0.165"	9/16	0.429"	0.370"	0.322"
1/4	0.255"	0.198"	0.191"	1/8PT	0.437"	0.378"	0.328"
5/16	0.318"	0.258"	0.238"	5/8	0.480"	0.422"	0.360"
7/16	0.323"	0.263"	0.242"	ER40G RIGID TAP COLLET			
d2	d1	SW	W □	d2	d1	SW	W □
1/2	0.367"	0.307"	0.275"	1/4	0.255"	0.198"	0.191"
3/8	0.381"	0.321"	0.286"	5/16	0.318"	0.258"	0.238"
9/16	0.429"	0.370"	0.322"	7/16	0.323"	0.263"	0.242"
ER32G RIGID TAP COLLET				1/2	0.367"	0.307"	0.275"
d2	d1	SW	W □	3/8	0.381"	0.321"	0.286"
5/32	0.168"	0.151"	0.131"	9/16	0.429"	0.370"	0.322"
3/16	0.194"	0.180"	0.152"	1/8PT	0.437"	0.378"	0.328"
7/32	0.220"	0.198"	0.165"	5/8	0.480"	0.422"	0.360"
1/4	0.255"	0.198"	0.191"	11/16	0.542"	0.486"	0.406"
5/16	0.318"	0.258"	0.238"	1/4PT	0.562"	0.483"	0.421"
7/16	0.323"	0.263"	0.242"	3/4	0.590"	0.512"	0.442"
1/2	0.367"	0.307"	0.275"	13/16	0.649"	0.576"	0.489"
3/8	0.381"	0.321"	0.286"	1/2PT	0.687"	0.612"	0.515"
9/16	0.429"	0.370"	0.322"	7/8	0.697"	0.623"	0.523"
1/8PT	0.437"	0.378"	0.328"	3/8PT	0.700"	0.634"	0.531"
5/8	0.480"	0.422"	0.360"	15/16	0.760"	0.689"	0.570"
11/16	0.542"	0.486"	0.406"	1	0.800"	0.730"	0.600"
1/4PT	0.562"	0.483"	0.421"				
3/4	0.590"	0.512"	0.442"				
13/16	0.649"	0.576"	0.489"				

攻丝夹头系列 TAPPING CHUCK SERIES

## TER32 扭力攻牙筒夹

TER32 FOR COMPRESSION TAPER HOLDER

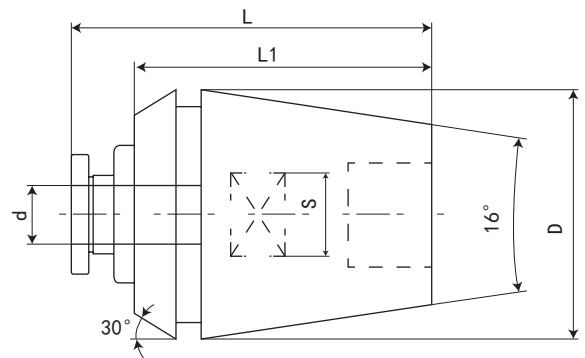

型号 / 规格 Model	夹持丝锥 (ISO 国标)	D	d	S	L	L1
TER32-M3	M3	33	3.15	2.5	48	40
TER32-M4	M4	33	4	3.15	48	40
TER32-M5	M5	33	5	4	48	40
TER32-M6	M6	33	6.3	5	48	40
TER32-M8	M8	33	6.3	5	48	40
TER32-M10	M10	33	8	6.3	48	40
TER32-M12	M12	33	9	7.1	48	40

### 特点:

注:

- ◎ 可用在 ER 刀柄上, 又可夹持丝锥实现扭力保护攻牙
- ◎ 扭力的变动灵敏、可根据不同的情况设定相应扭力
- ◎ 也可以用于不同的攻牙机和攻牙机体

### Features:

- ◎ Used for gripping cutting tool and tapping.
- ◎ Torsion reflect sensitive and changes according to various material to set up corresponding torque.
- ◎ Used for all kinds of tapping machine and electric tapping machine.

## TC32 扭力攻牙筒夹

TC32 FOR COMPRESSION TAPER HOLDER

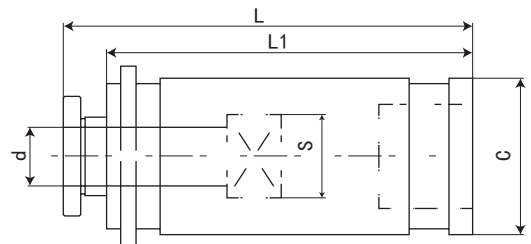

型号 / 规格 Model	夹持丝锥 (ISO 国标)	C	d	S	L	L1
TC32-M3	M3	32	3.15	2.5	63	55
TC32-M4	M4	32	4	3.15	63	55
TC32-M5	M5	32	5	4	63	55
TC32-M6	M6	32	6.3	5	63	55
TC32-M8	M8	32	6.3	5	63	55
TC32-M10	M10	32	8	6.3	63	55
TC32-M12	M12	32	9	7.1	63	55

### 特点:

注:

- ◎ 可用在 C32 强力刀柄上, 又可夹持丝锥实现扭力保护攻牙
- ◎ 扭力的变动灵敏、可根据不同的情况设定相应扭力
- ◎ 也可以用于不同的攻牙机和攻牙机体

### Features:

- ◎ Used for gripping cutting tool and tapping.
- ◎ Torsion reflect sensitive and changes according to various material to set up corresponding torque.
- ◎ Used for all kinds of tapping machine and electric tapping machine.

TAPPING  
CHUCK SERIES  
攻丝夹头系列

# 攻丝夹头系列 TAPPING CHUCK SERIES

## MTA 莫氏单支刚性攻丝夹头

## MTA MORSE RIGID TAPPING CHUCK

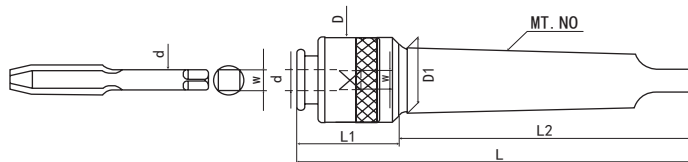

规格 / 型号 Model	MT.NO	攻牙范围 Tapping range	D	D1	d	W	L	L1	L2
MT2-M5	MT2	M5	21	17.780	5	4*4	104	20	84
MT2-M6-8	MT2	M6-M8	21	17.780	6.3	5*5	104	20	84
MT2-M10	MT2	M10	21	17.780	8	6.3*6.3	104	20	84
MT2-M12	MT2	M12	21	17.780	9	7.1*7.1	104	20	84
MT2-M14	MT2	M14	24	17.780	11.2	9*9	111	27	84
MT2-M16	MT2	M16	27	17.780	12.5	10*10	111	27	84
MT3-M6-8	MT3	M6-M8	27	23.825	6.3	5*5	120	21	99
MT3-M10	MT3	M10	27	23.825	8	6.3*6.3	120	21	99
MT3-M12	MT3	M12	27	23.825	9	7.1*7.1	120	21	99
MT3-M14	MT3	M14	27	23.825	11.2	9*9	120	21	99
MT3-M16	MT3	M16	27	23.825	12.5	10*10	120	21	99
MT3-M18-20	MT3	M18-20	29	23.825	14	11.2*11.2	126	27	99
MT3-M22	MT3	M22	33	23.825	16	12.5*12.5	130	31	99
MT3-M24	MT3	M24	33	23.825	18	14*14	130	31	99
MT3-M27-30	MT3	M27-30	37	23.825	20	16*16	150	51	99
MT4-M6-8	MT4	M6-M8	33	31.267	6.3	5*5	148	24	124
MT4-M10	MT4	M10	33	31.267	8	6.3*6.3	148	24	124
MT4-M12	MT4	M12	33	31.267	9	7.1*7.1	148	24	124
MT4-M14	MT4	M14	33	31.267	11.2	9*9	148	24	124
MT4-M16	MT4	M16	33	31.267	12.5	10*10	148	24	124
MT4-M18-20	MT4	M18-20	33	31.267	14	11.2*11.2	148	24	124
MT4-M22	MT4	M22	33	31.267	16	12.5*12.5	148	24	124
MT4-M24	MT4	M24	37	31.267	18	14*14	150	26	124
MT4-M27-30	MT4	M27-30	37	31.267	20	16*16	156	32	124
MT4-M33	MT4	M33	39	31.267	22.4	18*18	158	34	124
MT4-M36	MT4	M36	44	31.267	25	20*20	176	52	124
MT4-M39-42	MT4	M39-42	44	31.267	28	22.4*22.4	176	52	124
MT4-M45-48	MT4	M45-48	49	31.267	31.5	25*25	176	52	124
MT4-M52-56	MT4	M52-56	54	31.267	35.5	28*28	176	52	124
MT5-M33	MT5	M33	47	44.399	22.4	18*18	170	34	136
MT5-M36	MT5	M36	47	44.399	25	20*20	170	34	136
MT5-M39-42	MT5	M39-42	47	44.399	28	22.4*22.4	170	34	136
MT5-M45-48	MT5	M45-48	49	44.399	31.5	25*25	170	34	136
MT5-M52-56	MT5	M52-56	54	44.399	35.5	28*28	170	34	136

攻丝夹头系列  
TAPPING  
CHUCK SERIES

### 特点:

注:

- ◎ 本产品具有浮动、快换、便捷功能
- ◎ 适用于攻丝机、钻攻机、钻床等机床设备攻牙
- ◎ 最大攻丝范围 M5-M24

### Features:

- ◎ Floating, quick change, automatic regulatory function.
- ◎ Suitable for tapping machines, drilling attach machines, lathes and so on for tapping.
- ◎ Tapping range: M5-M24.



# J5230 钻孔攻丝快换夹头

## DRILL AND TAP QUICK CHANGE PROTECTION COLLET

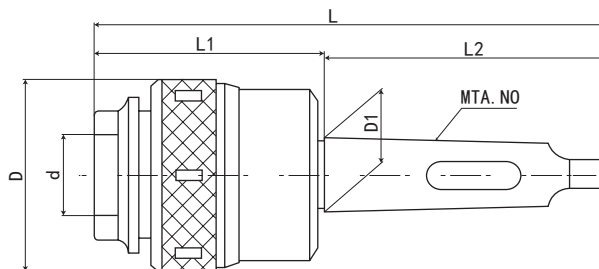

P. P38

规格 / 型号 Model	莫氏锥柄 Morse taper shank	钻孔范围 Drilling range	攻牙范围 Tapping range	快换变径套 Morse taper sleeve	快换攻丝夹头 Tapping collet chuck	D	d	L	L1	L2	D1	夹套 外径 d	组合内容 Tool Connection
MTA3-J5230	MTA3	1-31mm	M6-M30	MTA1/MTA2/ MTA3/B16	M6-8/M10/M12/M16/ M18-20/M24/M27-30	82	35	198	99	99	23.825	Φ35	1. 攻丝夹头 7 支 2. 变径套 3 支 3. B16 钻接杆 1 支 4. 主体 1 支
MTA4-J5230	MTA4	1-31mm	M6-M30	MTA1/MTA2/ MTA3/B16	M6-8/M10/M12/M16/ M18-20/M24/M27-30	82	35	223	99	124	31.267		
MTA5-J5230	MTA5	1-31mm	M6-M30	MTA1/MTA2/ MTA3/B16	M6-8/M10/M12/M16/ M18-20/M24/M27-30	82	35	255	99	156	44.399		
MTA4-J5242	MTA4	6-50.8mm	M16-M42	MTA1/MTA2/ MTA3/MTA4	M16/M18-20/M24/M27- 30/M36/M39-42	84	35	242	118	124	31.267	Φ35	1. 攻丝夹头 6 支 2. 变径套 4 支 3. 主体 1 支
MTA5-J5242	MTA5	6-50.8mm	M16-M42	MTA1/MTA2/ MTA3/MTA4	M16/M18-20/M24/M27- 30/M36/M39-42	84	35	274	118	156	44.399		



### 特点:

#### 注:

- ◎ 本产品具有钻孔、攻丝、扭力过载、保护丝锥等功能。
- ◎ 适合在钻床、攻丝机、镗床、车床等设备攻丝。
- ◎ 采用主体件内的磨擦片紧松，自如调节攻丝扭力大小。
- ◎ 本体规范：GB1443-1985

### Features:

- ◎ Spindle conicity standard: GB1443-1985
- ◎ With functions of drilling, tapping, torque protection.
- ◎ Used on radial drills, drilling attack machines, borers, lathes and so on for tapping.
- ◎ Adopt the friction disk in main body to adjust tap power of the torque to steady skid and protection tap.

TAPPING  
CHUCK SERIES  
攻丝夹头系列

# 攻丝夹头系列 TAPPING CHUCK SERIES

## J5130 钻孔快换夹头

## J5130 DRILL AND TAP QUICK CHANGE COLLET

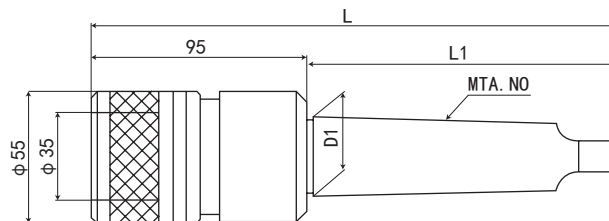

P.P38

规格 / 型号 Model	莫氏锥柄 Morse taper shank	钻孔范围 Drilling range	快换变径套 Morse taper sleeve	L	L1	D1	组合内容 Tool Connection
MTA3-J5130	MTA3	1-31mm	MTA1/MTA2/B16	194	99	23.825	1. 变径套 2支 2. B16 钻接杆 1支 3. 主体 1支
MTA4-J5130	MTA4	1-31mm	MTA1/MTA2/MTA3/B16	223	124	31.267	1. 变径套 3支 2. B16 钻接杆 1支 3. 主体 1支
MTA5-J5130	MTA5	6-50.8mm	MTA1/MTA2/MTA3/MTA4/ B16	251	156	44.399	1. 变径套 4支 2. B16 钻接杆 1支 3. 主体 1支

快换变径套及快换钻接杆与 J5230 通用

攻丝夹头系列  
TAPPING  
CHUCK SERIES



### 特点:

注:

- ◎ 本体规范: GB1443-1985
- ◎ 适合在钻床、攻丝机、镗床、车床等设备攻丝。
- ◎ 能解决大小孔径快速钻孔。
- ◎ 本产品具有经济实惠, 快速便捷功能。

### Features:

- ◎ Spindle conicity standard: GB1443-1985
- ◎ Used on radial drills, drilling attack machines, borers, lathes and so on for tapping.
- ◎ Can solve the problem for big or small aperture drilling.
- ◎ With function of quick change and convenience.

## J5230 快换攻丝夹头

## J5230 TAPPING COLLET CHUCK

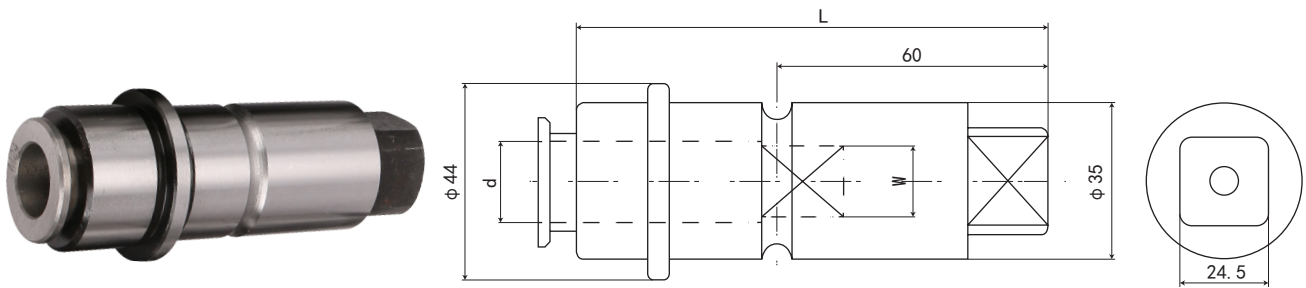

名称 Name	型号 Model	d	W	L	名称 Name	型号 Model	d	W	L
快换攻丝夹头 Tapping collet chuck	M6-8	6.3	5X5	111	快换攻丝夹头 Tapping collet chuck	M22	16	12.5X12.5	120
	M10	8	6.3X6.3	111		M24	18	14X14	120
	M12	9	7.1X7.1	111		M27-30	20	16X16	120
	M14	11.2	9X9	111		M33	22.4	18X18	130
	M16	12.5	10X10	111		M36	25	20X20	130
	M18-20	14	11.2X11.2	111	M39-42	28	22.4X22.4	130	

## J5230 快换变径套

## J5230 MORSE TAPER SLEEVE

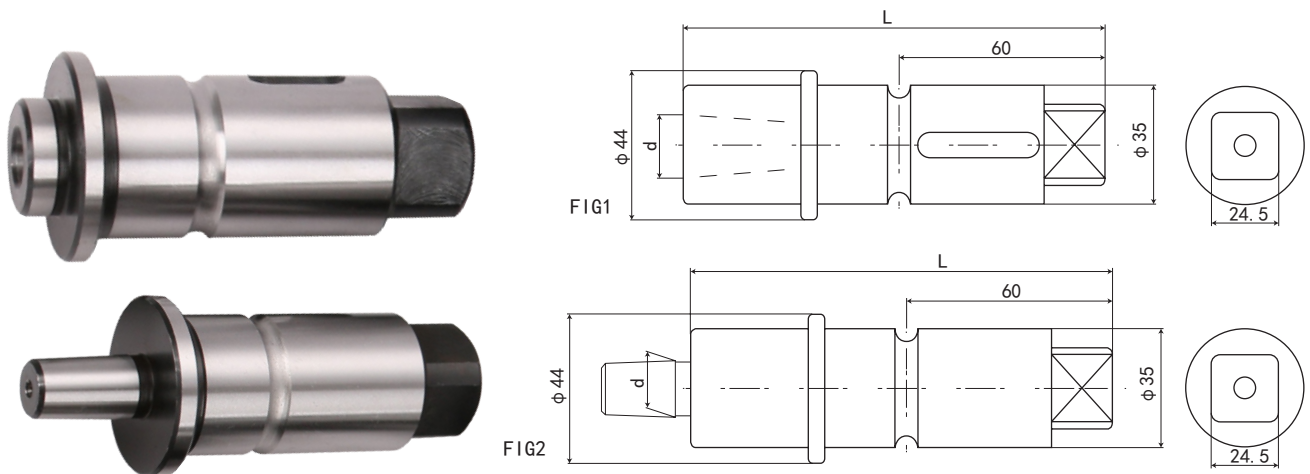

名称 Name	规格 / 型号 Model	d	L	FIG
快换变径套 Morse taper sleeve	MTA1	12.075	98	FIG1
	MTA2	17.780	109	
	MTA3	23.825	126	
	MTA4	31.267	153	
快换钻接杆 Drill chuck arbors	B16	15.733	118	FIG2
	B18	17.780	126	

TAPPING  
CHUCK SERIES  
攻丝夹头系列

# 攻丝夹头系列 TAPPING CHUCK SERIES

## J4016A 型钢性快换攻丝夹头 J4016A SYSTEM QUICK CHANGE TAP COLLET CHUCK SET

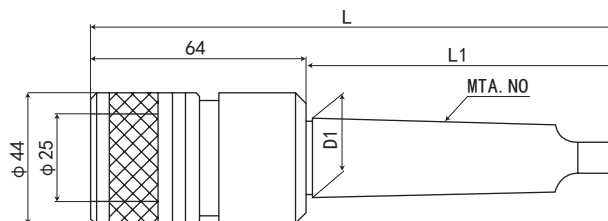

P.P41

规格 / 型号 Model	莫氏锥柄 Morse taper shank	攻牙范围 Tapping range	快换攻丝夹头 Tapping collet chuck	L	L1	D1	组合内容 Tool Connection
MTA3-J4016A	MTA3	M5-M16	M5/M6-8/M10/M12/M14/ M16	163	99	23.825	1. 主体 1 支 2. 攻丝夹头 6 支
MTA4-J4016A	MTA4	M5-M16	M5/M6-8/M10/M12/M14/ M16	188	124	31.267	1. 主体 1 支 2. 攻丝夹头 6 支
MTA5-J4016A	MTA5	M5-M16	M5/M6-8/M10/M12/M14/ M16	220	156	44.399	1. 主体 1 支 2. 攻丝夹头 6 支

攻丝夹头系列  
TAPPING  
CHUCK SERIES



### 特点:

注:

- ◎ 本产品具有浮动、快换、便捷功能
- ◎ 适用于攻丝机、钻攻机、钻床等机床设备攻牙
- ◎ 最大攻丝范围 M5-M16

### Features:

- ◎ Floating, quick change, automatic regulatory function.
- ◎ Suitable for tapping machines, drilling attach machines, lathes and so on for tapping.
- ◎ Tapping range: M5-M16.



# J4012A/J4016A /J4024A 转换套

## SYSTEM QUICK CHANGE TAP COLLET CHUCK SET

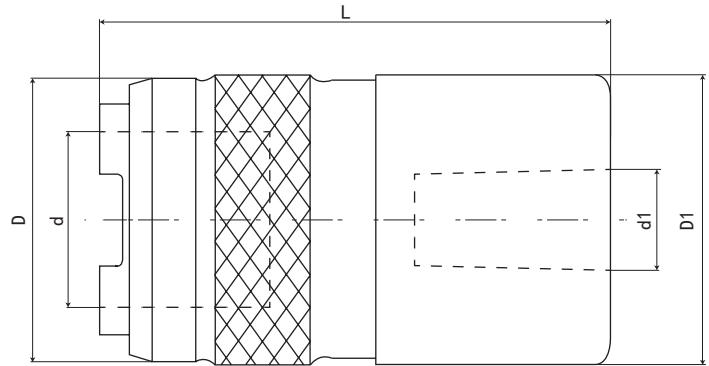

P.P41



P.S03

型号 / 规格 Model	攻牙范围 Tapping range	D	D1	d	d1	L	夹头名称 Collet name
B16-J4012A	M3-M12	35	35	19	15.733	53	M3/M4/M5/M6-8/M10/M12
B18-J4012A	M3-M12	35	35	19	17.780	53	M3/M4/M5/M6-8/M10/M12
B16-J4016A	M5-M16	44	44	25	15.733	65	M5/M6-8/M10/M12/M14/M16
B18-J4016A	M5-M16	44	44	25	17.780	65	M5/M6-8/M10/M12/M14/M16
B22-J4024A	M5-M24	51	38	30	21.793	93	M5/M6-8/M10/M12/M14/M16/M18-20/M22/M24



### 特点:

#### 注:

- ◎本产品具有浮动、快换、便捷功能
- ◎适用于攻丝机、钻攻机、钻床等机床设备攻牙
- ◎最大攻丝范围 M3-M24

### Features:

- ◎ Floating, quick change, automatic regulatory function.
- ◎ Suitable for tapping machines, drilling attach machines, lathes and so on for tapping.
- ◎ Tapping range: M3-M24.

TAPPING  
CHUCK SERIES  
攻丝夹头系列

# 攻丝夹头系列 TAPPING CHUCK SERIES

## J4012A/J4016A/J4024A 快换攻丝夹头

## TAPPING COLLET CHUCK

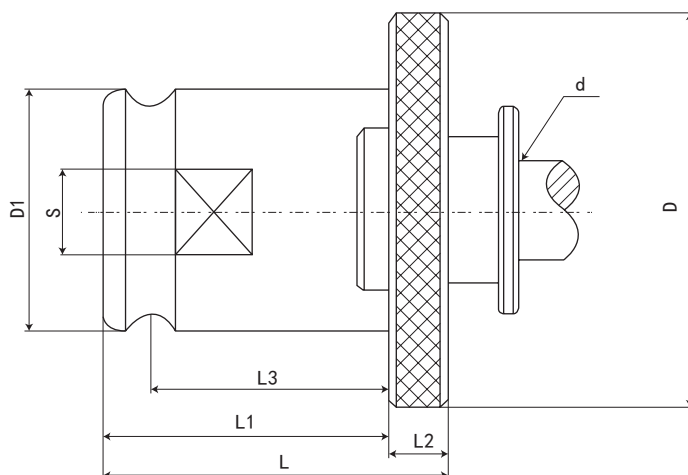

P. P39

型号 / 规格 Model	夹持丝锥 (ISO 国标)	D	D1	d	S	L	L1	L2	L3
J4012A-M3	M3	29	19	3.15	2.5	30	22	7	17.5
J4012A-M4	M4	29	19	4	3.15	30	22	7	17.5
J4012A-M5	M5	29	19	5	4	30	22	7	17.5
J4012A-M6-8	M6-8	29	19	6.3	5	30	22	7	17.5
J4012A-M10	M10	29	19	8	6.3	30	22	7	17.5
J4012A-M12	M12	29	19	9	7.1	30	22	7	17.5
型号 / 规格 Model	夹持丝锥 (ISO 国标)	D	D1	d	S	L	L1	L2	L3
J4016A-M5	M5	37	25	5	4	38	30	8	25
J4016A-M6-8	M6-8	37	25	6.3	5	38	30	8	25
J4016A-M10	M10	37	25	8	6.3	38	30	8	25
J4016A-M12	M12	37	25	9	7.1	38	30	8	25
J4016A-M14	M14	37	25	11.2	9	38	30	8	25
J4016A-M16	M16	37	25	12.5	10	38	30	8	25
型号 / 规格 Model	夹持丝锥 (ISO 国标)	D	D1	d	S	L	L1	L2	L3
J4024A-M5	M5	47	30	5	4	42	30	12	25
J4024A-M6-8	M6-8	47	30	6.3	5	42	30	12	25
J4024A-M10	M10	47	30	8	6.3	42	30	12	25
J4024A-M12	M12	47	30	9	7.1	42	30	12	25
J4024A-M14	M14	47	30	11.2	9	42	30	12	25
J4024A-M16	M16	47	30	12.5	10	42	30	12	25
J4024A-M18	M18	47	30	14	11.2	42	30	12	25
J4024A-M20	M20	47	30	14	11.2	42	30	12	25
J4024A-M22	M22	47	30	16	12.5	42	30	12	25
J4024A-M24	M24	47	30	18	14	42	30	12	25

### 特点:

注:

- ◎ 本产品具有浮动、快换、便捷功能
- ◎ 适用于攻丝机、钻攻机、钻床等机床设备攻牙
- ◎ 最大攻丝范围 M3-M24

### Features:

- ◎ Floating, quick change, automatic regulatory function.
- ◎ Suitable for tapping machines, drilling attach machines, lathes and so on for tapping.
- ◎ Tapping range: M3-M24.



# J4016B 型钢性快换攻丝夹头

# J4016B SYSTEM QUICK CHANGE TAP COLLET CHUCK SET

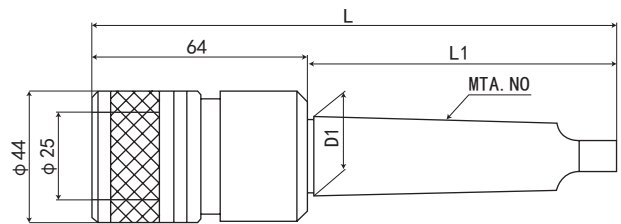

P. P44

规格 / 型号 Model	莫氏锥柄 Morse taper shank	攻牙范围 Tapping range	快换攻丝夹头 Tapping collet chuck	L	L1	D1	组合内容 Tool Connection
MTA3-J4016B	MTA3	M5-M16	M5/M6-8/M10/M12/M14/M16	163	99	23.825	1. 主体 1 支 2. 攻丝夹头 6 支
MTA4-J4016B	MTA4	M5-M16	M5/M6-8/M10/M12/M14/M16	188	124	31.267	1. 主体 1 支 2. 攻丝夹头 6 支
MTA5-J4016B	MTA5	M5-M16	M5/M6-8/M10/M12/M14/M16	220	156	44.399	1. 主体 1 支 2. 攻丝夹头 6 支



## 特点:

### 注:

- ◎ 本产品具有浮动、快换、便捷功能
- ◎ 适用于攻丝机、钻攻机、钻床等机床设备攻牙
- ◎ 最大攻丝范围 M5-M16

## Features:

- ◎ Floating, quick change, automatic regulatory function.
- ◎ Suitable for tapping machines, drilling attach machines, lathes and so on for tapping.
- ◎ Tapping range: M5-M16.



# 攻丝夹头系列 TAPPING CHUCK SERIES

## J4016B /J4024B 转换套

## SYSTEM QUICK CHANGE TAP COLLET CHUCK SET

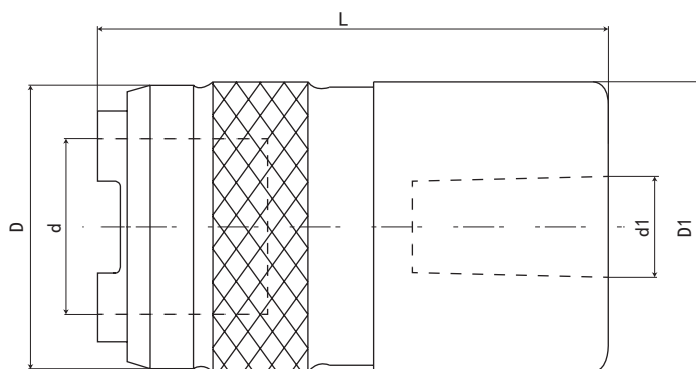

型号 / 规格 Model	攻牙范围 Tapping range	D	D1	d	d1	L	夹头名称 Collet name
B16-J4016B	M5-M16	44	43	28	15.733	67	M5/M6-8/M10/M12/M14/M16
B18-J4016B	M5-M16	44	43	28	17.780	67	M5/M6-8/M10/M12/M14/M16
B22-J4024B	M5-M24	59	49	36	21.793	104	M5/M6-8/M10/M12/M14/M16/M18-20/M22/M24



### 特点:

#### 注:

- ◎本产品具有浮动、快换、便捷功能
- ◎适用于攻丝机、钻攻机、钻床等机床设备攻牙
- ◎最大攻丝范围 M3-M24

### Features:

- ◎ Floating, quick change, automatic regulatory function.
- ◎ Suitable for tapping machines, drilling attach machines, lathes and so on for tapping.
- ◎ Tapping range: M3-M24.



## J4016B 快换攻丝夹头

### TAPPING COLLET CHUCK

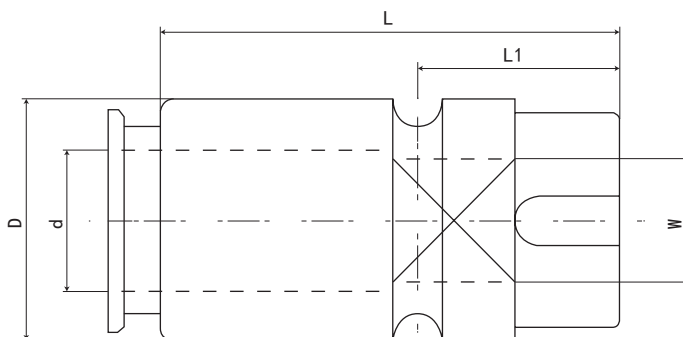
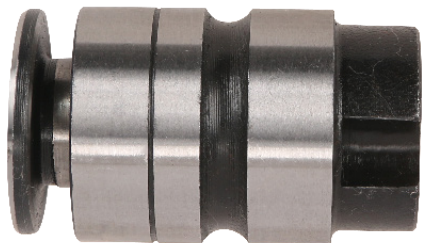

型号 / 规格 Model	夹持丝锥 (ISO 国标)	D	d	W	L	L1
J4016B-M3	M3	28	3.15	2.5	40	22.5
J4016B-M4	M4	28	4	3.15	40	22.5
J4016B-M5	M5	28	5	4	40	22.5
J4016B-M6-8	M6-8	28	6.3	5	40	22.5
J4016B-M10	M10	28	8	6.3	40	22.5
J4016B-M12	M12	28	9	7.1	40	22.5
J4016B-M14	M14	28	11.2	9	40	22.5
J4016B-M16	M16	28	12.5	10	40	22.5

#### 特点:

##### 注:

- ◎ 本产品具有浮动、快换、便捷功能
- ◎ 适用于攻丝机、钻攻机、钻床等机床设备攻牙
- ◎ 最大攻丝范围 M3-M16

#### Features:

- ◎ Floating, quick change, automatic regulatory function.
- ◎ Suitable for tapping machines, drilling attach machines, lathes and so on for tapping.
- ◎ Tapping range: M3-M16.

## J4024B 快换攻丝夹头

### TAPPING COLLET CHUCK

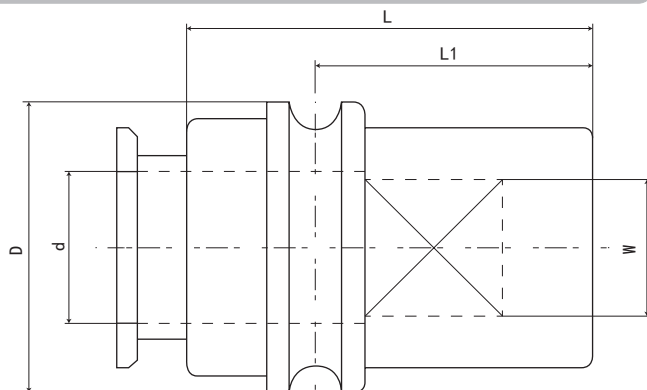
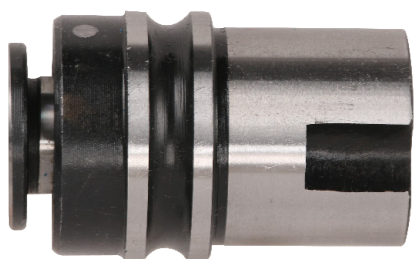

型号 / 规格 Model	夹持丝锥 (ISO 国标)	D	d	W	L	L1
J4024B-M5	M5	36	5	4	50	35
J4024B-M6-8	M6-8	36	6.3	5	50	35
J4024B-M10	M10	36	8	6.3	50	35
J4024B-M12	M12	36	9	7.1	50	35
J4024B-M14	M14	36	11.2	9	50	35
J4024B-M16	M16	36	12.5	10	50	35
J4024B-M18-20	M18-20	36	14	11.2	50	35
J4024B-M22	M22	36	16	12.5	50	35
J4024B-M24	M24	36	18	14	50	35

#### 特点:

##### 注:

- ◎ 本产品具有浮动、快换、便捷功能
- ◎ 适用于攻丝机、钻攻机、钻床等机床设备攻牙
- ◎ 最大攻丝范围 M5-M24

#### Features:

- ◎ Floating, quick change, automatic regulatory function.
- ◎ Suitable for tapping machines, drilling attach machines, lathes and so on for tapping.
- ◎ Tapping range: M5-M24.

# 攻丝夹头系列 TAPPING CHUCK SERIES

## TC- 系列一体式多用攻丝夹头

TC SERIES-ONE-PIECE MULTI-PURPOSE TAPPING CHUCK

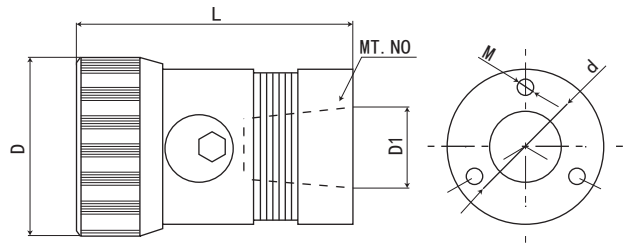
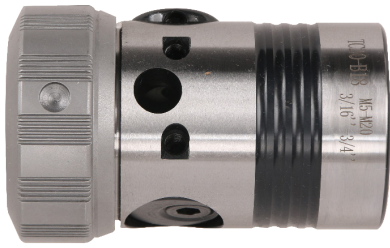

P.S03

规格 / 型号 Model	夹持范围 Capacity	丝锥柄径范围 tapping holder diameter	连接锥度 Jacobs Taper Shank	D	D1	L	d	M
TC13-B16	M2-M13 1/8"-1/2"	φ2.5-φ10	B16	48	15.733	73	36	M5
TC13-JT6	M2-M13 1/8"-1/2"	φ2.5-φ10	JT6	48	17.170	73	36	M5
TC16-B18	M3-M16 1/8"-5/8"	φ3-φ12.5	B18	54	17.780	76	36	M5
TC16-JT6	M3-M16 1/8"-5/8"	φ3-φ12.5	JT6	54	17.170	76	36	M5
TC20-B18	M5-M20 3/16"-3/4"	φ4.5-φ15	B18	54	17.780	85	36	M5
TC20-JT6	M5-M20 3/16"-3/4"	φ4.5-φ15	JT6	54	11.170	85	36	M5
TC24-B22	M12-M24 1/2"-15/16"	φ8.5-φ18	B22	60	21.793	95	36	M5

## TC-BT 系列一体式多用攻丝夹头

TC-BT SERIES-ONE-PIECE MULTI-PURPOSE TAPPING CHUCK

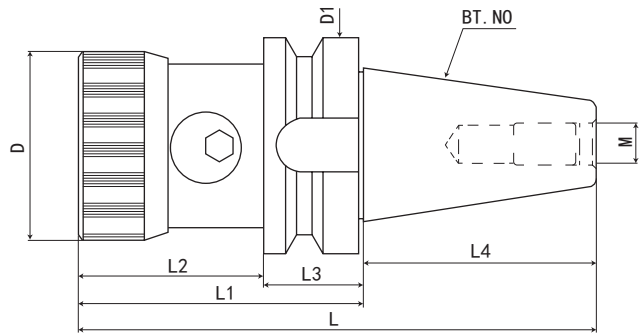

P.129

规格 / 型号 Model	夹持范围 Capacity	丝锥柄径范围 tapping holder diameter	连接锥度 Jacobs Taper Shank	D	D1	L	L1	L2	L3	L4	M
TC13-BT40	M2-M13 1/8"-1/2"	φ2.5-φ10	BT40	48	63	153.4	88	61	27	65.4	M16*2.0P
TC16-BT40	M3-M16 1/8"-5/8"	φ3-φ12.5	BT40	54	63	153.4	88	61	27	65.4	M16*2.0P
TC20-BT40	M5-M20 3/16"-3/4"	φ4.5-φ15	BT40	54	63	153.4	88	61	27	65.4	M16*2.0P

### 特点:

#### 新品特色:

- ◎ 精度高、稳定性好
- ◎ 夹持范围可自由调节
- ◎ 强扭力刚性攻丝
- ◎ 快换、装卸方便
- ◎ 适用范围广: 攻丝机床、钻床、高速车床、CNC 加工中心及其它可反转的主轴
- ◎ 丝锥夹持方法: 转动夹头前套, 使夹爪伸缩到比丝锥柄径稍大一点, 装上丝锥, 然后转动双头螺丝, 通过观察孔观察, 使双头螺丝上的两个偏心螺母轻轻夹住丝锥的四方, 接着转动前套, 夹紧丝锥并用配套扳手夹紧, 最后用六角扳手锁紧双头螺丝, 夹紧丝锥四方。

### Features:

#### Product features:

- ◎ The high precision and good stability.
- ◎ The clamping range can be adjusted freely.
- ◎ Strong torsion rigidity tapping.
- ◎ Quick change, easy loading and unloading.
- ◎ Applicable range: tapping machine, drilling machine, high speed lathe, CNC machining center and other main shaft can be reversed.
- ◎ Tap clamping method: rotating chuck front sleeve, the clamp claws stretch to than taper shank diameter slightly larger, mounted on the tap, then turning the double screw, through the observation hole, observation, the double headed screws on the two eccentric clamp nut lightly tap the Quartered, and then rotate the front sleeve, clip on wire cone and the matching spanner clamping, and finally with the six angle wrench locking stud bolts, clamping tap square.



## TC-MTA 系列一体式多用攻丝夹头

TC-MTA SERIES-ONE-PIECE MULTI-PURPOSE TAPPING CHUCK

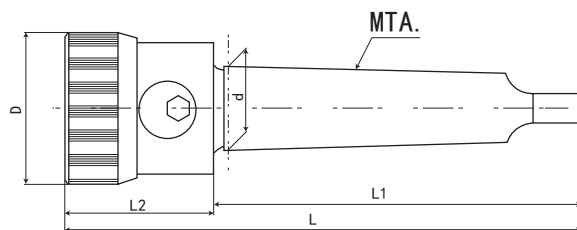
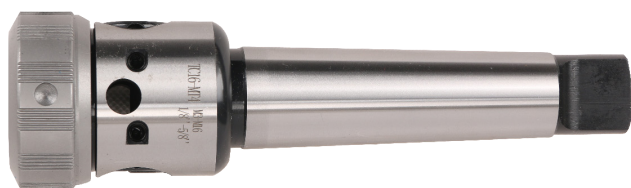

规格 / 型号 Model	夹持范围 Capacity	丝锥柄径范围 tapping holder diameter	连接锥度 Jacobs Taper Shank	D	L	L1	L2
TC13-MTA2	M2-M13 1/8"-1/2"	φ2.5-φ10	MT2	48	154	84	70
TC16-MTA2	M2-M13 1/8"-1/2"	φ2.5-φ10	MT2	48	154	84	70
TC16-MTA3	M3-M16 1/8"-5/8"	φ3-φ12.5	MT3	54	169	99	70
TC16-MTA4	M3-M16 1/8"-5/8"	φ3-φ12.5	MT4	54	194	124	70
TC20-MTA3	M5-M20 3/16"-3/4"	φ4.5-φ15	MT3	54	169	99	70
TC20-MTA4	M5-M20 3/16"-3/4"	φ4.5-φ15	MT4	54	194	124	70
TC24-MTA3	M12-M24 1/2"-15/16"	φ8.5-φ18	MT3	60	179	99	80
TC24-MTA4	M12-M24 1/2"-15/16"	φ8.5-φ18	MT4	60	204	124	80

## TC-C 直柄系列一体式多用攻丝夹头

TC-C SERIES-ONE-PIECE MULTI-PURPOSE TAPPING CHUCK

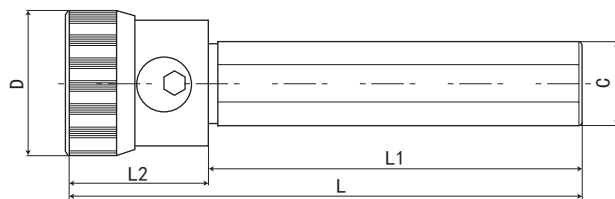

规格 / 型号 Model	夹持范围 Capacity	丝锥柄径范围 tapping holder diameter	直柄柄径 Straight shank diameter	D	C	L	L1	L2
TC13-C20	M2-M13 1/8"-1/2"	φ2.5-φ10	C20	48	20	150	80	70
TC16-C20	M3-M16 1/8"-5/8"	φ3-φ12.5	C20	54	20	150	80	70
TC20-C20	M5-M20 3/16"-3/4"	φ4.5-φ15	C20	54	20	150	80	70
TC13-C25	M2-M13 1/8"-1/2"	φ2.5-φ10	C25	48	25	150	80	70
TC16-C25	M3-M16 1/8"-5/8"	φ3-φ12.5	C25	54	25	150	80	70
TC20-C25	M5-M20 3/16"-3/4"	φ4.5-φ15	C25	54	25	150	80	70

### 产品性能:

产品具有夹持范围可调, 夹持范围内的英制、美制、公制及特殊尺寸的非标丝锥都可使用; 本品整体使用优质材料, 经整体淬火, 具有高精度, 强扭力, 高耐用等特色。

### 适用范围:

常用于“西湖牌”等台式攻丝机以及气动、电动等各类攻丝机, 并可用于车床、铣床、CNC 等刚性攻丝。

### Product performance:

Product performance: the product has a clamping range adjustable, non standard screw tap clamping range of British, American, metric and special size can use; this product is overall the use of high-quality materials, the overall quenching, with high precision, high torque, high resistance to use and other characteristics.

### The Applicable Range:

Scope of application: used in the "West Lake card" bench tapping machine and pneumatic, electric and other kinds of tapping machine, lathe, milling machine, and can be used for CNC rigid tapping.

TAPPING  
CHUCK SERIES  
攻丝夹头系列



# 攻丝夹头系列 TAPPING CHUCK SERIES

## DT33 莫氏钻攻快换套装

## DT33 MORSE DRILL TAPPING QUICK CHANGE KIT



### DT33 莫氏钻攻快换套装

- 旋臂攻牙本体 × 1pc
- JTA6+13H-JT6 × 1set
- 钻头套筒 × 2pcs
- 丝攻筒夹 × 6pcs
- L 型调整扳手 × 1pc

规格 / 型号 Model	组合系统 - 主轴 柄规格	标准尺寸	重量 KGS
DT33-MT3	DT33-MT3	JTA6+13H-JT6	11.3
DT33-MT4	DT33-MT4	M8,M10,M12,M16,M20,M24	11.7
DT33-MT5	DT33-MT5	MT2, MT3	12.6

### 丝攻筒夹

规格 / 型号 Model	丝锥夹头	重量 KGS
DT33	M6.M8.M10.M12.M14.M16.M18.M20.M22.M24.M27.M30.M32.M33.M34.M36.W1/4.W5/16.W3/8. W7/16.W1/2.W5/8.W3/4.W7/8.W1.W1-1/8.W1-1/4.PT1/8.PT1/4.PT3/8.PT1/2.PT3/4.PT1	0.6

### 丝攻筒夹规格表

JIS	φd	□
DT33 M06 W1/4	6	4.5
DT33 M08	6.2	5
DT33 M10 W3/8	7	5.5
DT33 M12	8.5	6.5
DT33 M14	10.5	8
DT33 M16	12.5	10
DT33 M18 W3/4 PT3/8	14	11
DT33 M20	15	12
DT33 M22 W7/8	17	13
DT33 M24	19	15
DT33 M27 W1 PT5/8	20	15
DT33 M30 PT3/4	23	17
DT33 M32 PY7/8 W1-1/4	24	19
DT33 M33	25	19
DT33 M34 PT1 W1-3/8	26	21
DT33 M36 PT1-1/8	28	21
DT33 W5/16	6.1	5
DT33 W7/16 PT1/8	8	6
DT33 W1/2	9	7
DT33 W5/8	12	9
DT33 W1-1/8	22	17
DT33 PT1/4	11	9
DT33 PT1/2	18	14

ISO	φd	□
DT33 M08	8	6.3
DT33 M10	10	8
DT33 M12	9	7.1
DT33 M14	11.2	9
DT33 M16	12.5	10
DT33 M18 M20	14	11.2
DT33 M22	16	12.5
DT33 M24	18	14
DT33 M27 M30	20	16
DT33 M33	22.4	18
DT33 M36	25	20

DIN376	φd	□
DT33 M08	6	4.9
DT33 M10	7	5.5
DT33 M12	9	7
DT33 M14	11	9
DT33 M16	12	9
DT33 M18	14	11
DT33 M20	16	12
DT33 M22 M24	18	14.5
DT33 M27	20	16
DT33 M30	22	18
DT33 M33	25	20
DT33 M36	28	22

DIN371	φd	□
DT33 M08	8	6.2
DT33 M10	10	8



攻丝夹头系列  
TAPPING  
CHUCK SERIES